

# CARES Technical Approval Report TA7 5041



Issue 5

**Leviat**  
A CRH COMPANY

## **Ancon SHEARFIX Punching Shear Reinforcement System**

Assessment of the  
Ancon SHEARFIX  
Punching Shear  
Reinforcement System  
and Quality System  
for Production

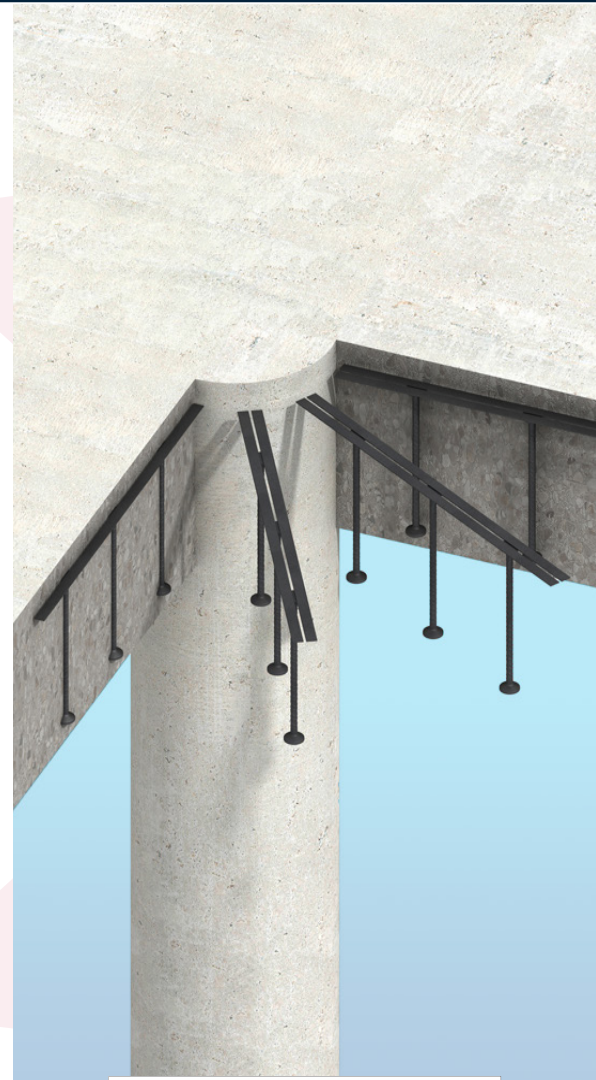

Electronic Copy [www.carescertification.com](http://www.carescertification.com)

# Product

## Ancon SHEARFIX Reinforcement Continuity System

### Product approval held by:

Leviat  
President Way, President Park  
Sheffield S4 7UR  
Tel: +44 (0) 114 275 5224  
Fax: +44 (0) 114 276 8543  
Email: [info.ancon.uk@leviat.com](mailto:info.ancon.uk@leviat.com)  
Web: [Ancon.co.uk](http://Ancon.co.uk) | [Leviat.com](http://Leviat.com)

## 1 Product Summary

The Ancon SHEARFIX system comprises lengths of carbon steel reinforcing bar with end anchorages provided by enlarged, hot forged heads at both ends three times the diameter of the bar.

The double-headed Ancon shear studs are welded to non-structural rails to allow them to be located correctly in accordance with the appropriate design standard, and where appropriate to be supported by the top flexural reinforcement.

### 1.1 Scope of Application

The Ancon SHEARFIX Punching Shear Reinforcement System has been evaluated for use in ordinary reinforced and post-tensioned concrete slabs and column bases designed in accordance with BS EN 1992-1-1 (Eurocode 2) and the UK National Annex. It is also suitable as shear reinforcement in piled ground slabs, rafts, etc. as an alternative to traditional loose links for both punching and linear shear applications.

### 1.2 Design Considerations

Eurocode 2 (EC2) describes punching shear reinforcement in terms of traditional links or bent-up bars arranged along perimeters at calculated distances around a loaded area (e.g. column or pile); with these calculations being relative to the size and position of the loaded area in conjunction with the depth and construction of the adjoining slab.

Where proprietary products are to be used as punching shear reinforcement, EC2 requires that  $V_{Rd,cs}$  (the design value of punching shear resistance of a slab with shear reinforcement at the basic control perimeter  $u_1$ ) should be determined by testing.

The approval does not cover designs of shear reinforcement to BS8110, which has been withdrawn. This should not present a problem in situations where a structure, including the flexural reinforcement of its floor slabs has been designed to BS8110. The shear reinforcement can be safely designed and detailed to EC2.

The performance of the system should be experimentally validated against a design method, and the test results should show that the system functions essentially as designed and gives resistances at least equal to the calculated characteristic resistances.



In the view of CARES, double headed shear studs that have been experimentally validated for punching shear may also be used for linear shear in slabs in which the flexural reinforcement complies with clause 9.3.1 of Eurocode 2. The slab edges should contain longitudinal and transverse reinforcement arranged as shown in Figure 9.8 of the code. Additionally, the spacing of the U bars should comply with the requirements of clause 9.3.2 of Eurocode 2 for shear reinforcement. The minimum distance to the slab edge from the stud centreline should not be less than  $4.5\phi$  where  $\phi$  is the stud diameter.

Deviations from the design standard in relation to detailing requirements and / or other limits require additional structural testing.

The design standard contains various detailing requirements, particularly in relation to the spacing of the elements of shear reinforcement and various limits on, for example, the concrete compressive strength which may be taken into account when designing against shear in slabs.

The principal detailing requirements and main equations of EC2 for punching shear are given in Sections 3.3 and 6 of this Technical Approval. Section 6 includes a treatment of a slab-column connection at a re-entrant corner. This is a case not considered directly in Eurocode 2, but the treatment is in accordance with the principles of EC2.

The rails allow either 'top down' or 'bottom up' installation of the shear reinforcement (section 4).

### 1.3 Conclusion

It is the opinion of CARES that Leviat's Ancon SHEARFIX Punching Shear Reinforcement System is satisfactory for use within the limits stated in paragraph 1.1 when applied and used in accordance with the manufacturer's instructions and the requirements of this certificate.

*Lee Brankley*

L. Brankley  
Chief Executive Officer  
December 2023



## 2 Technical Specification

### 2.1 General

The Ancon SHEARFIX system comprises double-headed studs welded to flat rails. It is manufactured to suit the specific requirements of each application. The quantity of each component, the dimensions and spacings, and the layout pattern around the column are determined by calculation. Leviat provides free software to determine the optimum system design.

Studs are manufactured in 5 diameters (10, 12, 16, 20 and 25mm) from CARES-approved B500C reinforcing bars and CARES-approved B500B reinforcing bars. The heads are hot forged to three times the diameter of the bar. Studs are manufactured in virtually any length to suit the depth of the slab, but are normally formed in increment within the 100-1000mm range. The first and last stud from each production batch is tested in-house to ensure the correct mechanical properties are maintained.

The studs are welded to the rails at the centres determined by Leviat's software or a design calculation. The rails perform no structural function but ensure stud alignment and positioning within the slab. Rails are manufactured from strips of steel which are 16mm wide x 3mm thick on studs up to 16mm diameter and 20mm x 5mm on the larger two stud diameters. The rails feature rounded ends to reduce the risk of injury during handling. The gap between the strips allows for the flow of concrete during pouring and also enables the rail to be nailed through spacers to formwork when fixed 'bottom-up'.



Figure 1 - SHEARFIX

## 3 Product Performance and Characteristics

### 3.1 Material Properties

Ancon SHEARFIX shear studs are manufactured from Grade B500B and B500C ribbed carbon steel reinforcing bar, with a characteristic yield strength of 500N/mm<sup>2</sup>, which fully complies with BS4449:2005. The rails to which the studs are welded are nominally 16mm x 3mm for studs up to 16mm in diameter and 20mm x 5mm for 20mm and 25mm studs. The rails are a hot rolled carbon steel Grade HR4 to BS EN 10025 or equivalent.

### 3.2 Production Processes

The Ancon SHEARFIX system comprises a series of double-headed shear studs which are formed from cut lengths of reinforcing steel. The heads which are three times the diameter of the bar are formed by a hot upset forging process.

The inherent strength of the parent bar is retained within the forged studs, by maintaining the homogeneous metal grain flow and being quenched and self-tempered, this gives the finished studs a high strength outer layer, with a more ductile core.

The studs are then welded to the rails at the prescribed centres in accordance with the structural design under a BS EN ISO 9001 Quality Management System.



### 3.3 Design Method and Detailing Requirements

The design method for SHEARFIX punching shear reinforcement is that of EC2's sections 6.4 and 9.4.3 supplemented by the non-contradictory treatment of re-entrant corners given in section 6.2 of this report. For prestressed slabs there is some confusion in EC2 as to the calculation of the shear carried by the vertical components of the tendon forces, as sections 6.4 and 9.4.3 are mutually contradictory. It is the opinion of CARES that section 9.4.3 is preferable and that the forces should be calculated for the locations at which the tendons cross a perimeter at a distance  $d/2$  from the column, where  $d$  is the effective depth of a tendon.

#### The general detailing requirements for punching shear are:

- The distance from the face of the loaded area to the first stud should be between  $0.3d$  and  $0.5d$  when using a radial pattern layout.
- The centres of subsequent studs along the rails should not exceed  $0.75d$ .
- The outermost perimeter of shear reinforcement should be placed at a distance not exceeding  $1.5d$  within the outer perimeter beyond which shear reinforcement is no longer required.

Studs may be used as reinforcement for linear shear in slabs provided compression longitudinal reinforcement is not included in the flexural resistance calculation. The shear reinforcement should be designed in accordance with Section 6.2.3 of Eurocode 2. The placement of studs within the depth of the slab should be as described in Section 4.1 of this Technical Approval. The maximum longitudinal and transverse spacings of the studs should respectively be in accordance with requirements of clauses 9.3.2 (4) and 9.3.2 (5) of Eurocode 2. The maximum diameter of studs used for linear shear should not exceed  $\phi_{\max} = 16\sqrt{d/200}$

Reference should be made to EC2 for more comprehensive information.

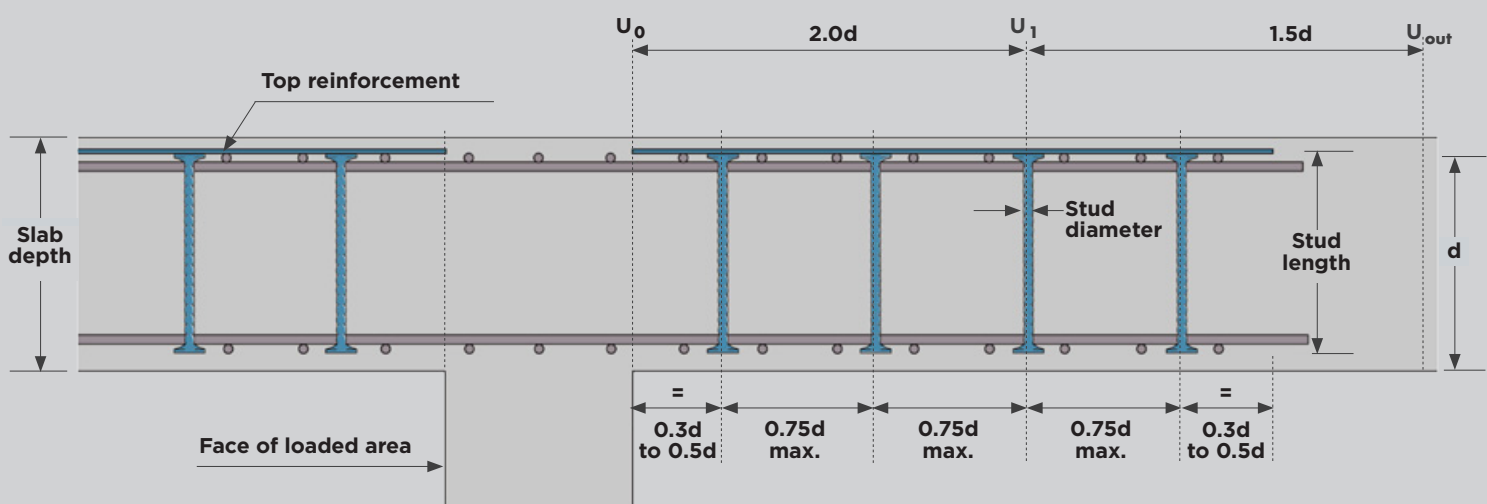

**Figure 2**  
Detailing requirements



Electronic Copy www.carescertification.com

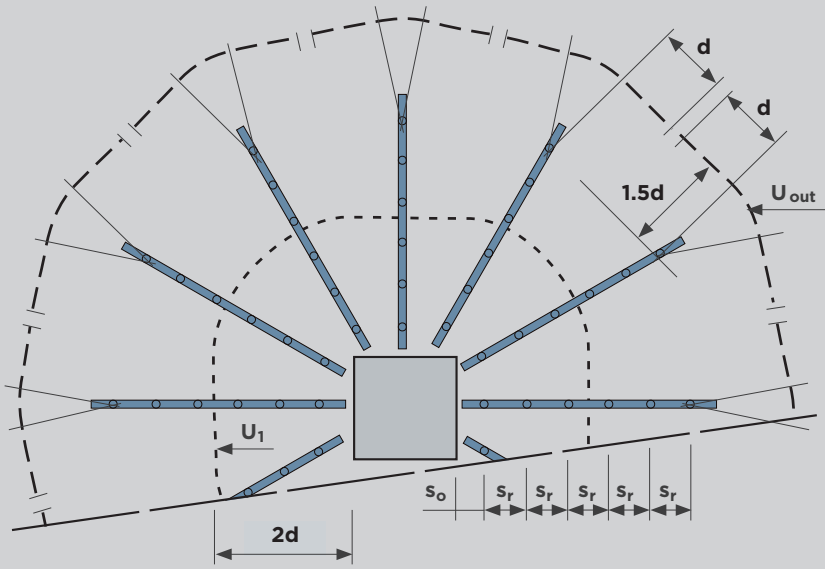

Radial  $s_{t,max} > 2d$   
 $0.3d \leq s_o \leq 0.5d$   $s_r \leq 0.75d$

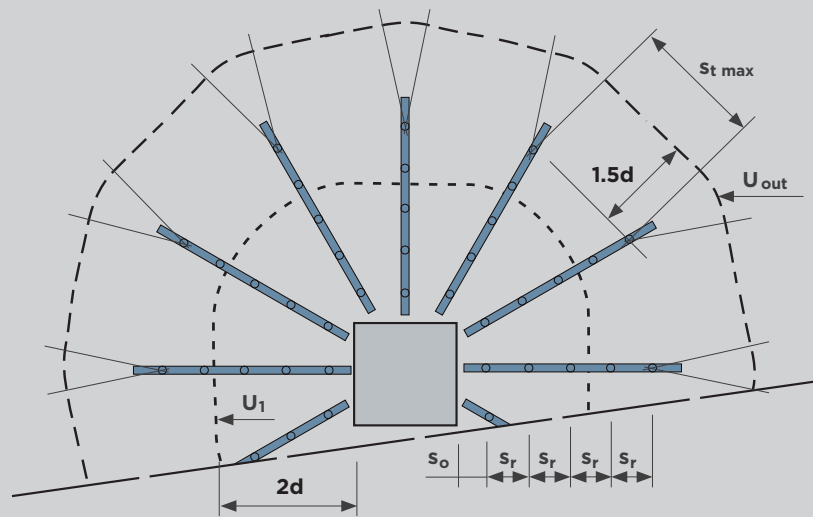

Radial  $s_{t,max} \leq 2d$   
 $0.3d < s_o \leq 0.5d$   $s_r \leq 0.75d$

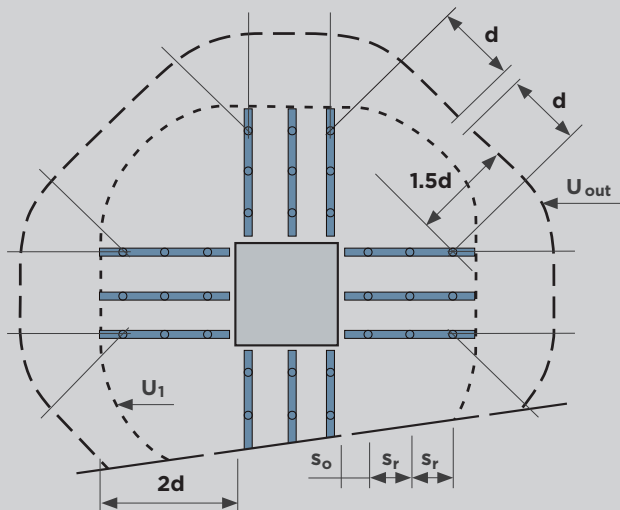

Cruciform  $s_{t,max} > 2d$   
 $0.3d < s_o \leq 0.5d$   $s_r \leq 0.75d$

Figure 3  
 Detailing requirements

## 4 Installation

### 4.1 Placement of the Studs

Each rail is labelled with specific stud and rail information so that it can easily be identified by the installers.

The studs must always 'capture' the main reinforcement of the slab. Thus in flat slabs the top of the upper head is level with the top surface of the upper T1 main bars and in column bases the bottom of the lower head is level with the undersides of the lower B1 main bars. In the compression zones of flat slabs, the bottoms of the lower heads should be level with the underside of the B1 bars and for column bases the tops of the upper heads should be level with the tops of the T1 bars. In compression zones, a tolerance equal to half the diameter of the B1 or T1 bars is acceptable, i.e. the stud heads may be up to half a bar diameter to the inside of the outer plane of the compression reinforcement.

Ancon SHEARFIX can be installed either 'top down' (after all other reinforcement) or 'bottom up' (prior to other reinforcement).

For 'top down' installation, the rails are placed on top of the top main T1 reinforcement, passing the studs through the reinforcement grid after the main reinforcement has been installed. The rails are tied to the main reinforcement to hold them in place prior to pouring the concrete.

For situations where the rails run parallel to the T1 reinforcement, spacer bars can simply be welded or wire tied to the main T2 reinforcement to raise the level of the rails so that they sit at the same height as if they were placed directly on the T1 bars. The spacer bars can be supplied as required.

For 'bottom up' installation the rails are tied with wire to the concrete spacers in order to maintain cover. If permitted nails can be hammered through gaps in the rails to fix the system to the formwork. The reinforcement cage is then fixed in position carefully to avoid displacing the studs and concrete is poured.

### 4.2 Storage

The Ancon SHEARFIX rails are delivered to site stacked on pallets and the rails are interlaced to provide stability and to reduce the risk of damage during transportation. The stacks are secured with steel bands then heat shrink wrapped securely to the pallets. Cardboard edge protectors are provided for safety. Each pallet is labelled, to show the contents, this will relate to the information given on the rail labels (section 4.1) and this should be retained to help with identification.

The pallets can be offloaded via forklift or crane (with appropriate slings or lifting system as required). It is recommended where possible that the pallets are stored in the area of site where they are likely to be used to ensure ease of access. It is also wise to store the pallets in such a location as once the steel bands have been cut there is a tendency for the load to shift, and become less stable, making it more difficult to move again as a safe load.



Although Ancon SHEARFIX is fabricated from carbon steel and is therefore robust in nature, it is good practice to store the rails away from areas where damage may occur.

Once Ancon SHEARFIX is exposed to the elements it can be treated as normal steel reinforcement. Over time the studs and rails may show some signs of surface rust, which is highly unlikely to impair structural integrity, however if exposure is expected to continue for many months of inclement weather, it is considered good practise to provide some protection.

## 5 Safety Considerations

Individual rails are lightweight and portable by one site operative. Care should be taken when cutting the steel bands around the rails. As with all site operations it is recommended that appropriate safety and PPE should be worn to protect the operatives, such as gloves, eye protection and safety footwear.

Care should be taken when handling long rails or studs, particularly on congested sites, where there is a risk of getting caught up with other equipment, or materials or personnel within the vicinity.

## 6 Product Testing and Evaluation

### 6.1 General

Independent testing of the Ancon Shearfix system for this CARES approval has been undertaken by the Cambridge University test facility. A series of structural tests have been completed to evaluate the shear performance to EC2 design standards in addition to the requirements of CARES Appendix TA7 “Quality and Operations Schedule for the Technical Approval of Stud Shear Reinforcement Systems for Flat Slabs”. In accordance with Ancon’s ISO9001 Quality Management system, a sample from each batch of shear studs is also tested to destruction in the factory to ensure that the tensile strength of the stud is maintained and to provide additional conformation of the compliance and suitability of the system to the design standards. Certificates of conformity are available if required.



In evaluating the performance of double-headed studs in relation to design by Eurocode 2, CARES has used the basic EC2 equations for characteristic punching resistances, with actual concrete strengths substituted for  $f_{ck}$ . Thus for a connection between an ordinary reinforced concrete slab and an interior column with no moment transfer:

i) The resistance of a slab without shear reinforcement is

$$V_{R,c} = v_{R,c} u_1 d \quad \dots (1)$$

ii) The resistance at the perimeter  $u_1$  provided by shear reinforcement is

$$V_{R,s} = \frac{(1.5d)}{s_r} A_{sw} f_{yw,eff} \quad \dots (2)$$

iii) The resistance at the perimeter  $u_1$  in a slab with shear reinforcement is

$$V_{R,cs} = 0.75V_{R,c} + V_{R,s} \leq 2 V_{R,c} \quad \dots (3)$$

where the upper limit is that of the UK National Annex

iv) The resistance at the perimeter  $u_{out}$ , 1.5d outside the outer shear reinforcement is

$$V_{R,out} = v_{R,c} u_{out} d \quad \dots (4)$$

v) The maximum resistance of a connection for a given column size and shape, a given slab effective depth and a given concrete strength is

$$V_{R,max} = 0.24 (1 - f_c/250) u_o d \quad \dots (5)$$

where

$d$  = effective depth of slab =  $(d_x + d_y)/2$

$u_o$  = length of column perimeter

$u_1$  = length of perimeter 2d from column (=  $u_o + 4\pi d$ )

$u_{out}$  =  $\sum s_t + 3\pi d$  where  $s_t$  is the circumferential spacing of the studs in the outer perimeter of studs  $\leq 2d$

$s_r$  = radial spacing of perimeters of studs

$v_{R,c} = 0.18 (100 \rho_1 f_c)^{1/3} (1 + \sqrt{200/d}) \leq 0.36 (100 \rho_1 f_c)^{1/3}$

$A_{sw}$  = area of shear reinforcement per perimeter of studs

$f_{yw,eff} = 1.15 (250 + 0.25d)$

The calculated strength prediction is then

$$V_{calc} = \min [V_{R,cs}, V_{R,out}, V_{R,max}] \geq V_{R,c} \quad \dots (6)$$

and should have a 95% probability of being achieved in a test

The Eurocode gives methods of treating slabs cast in lightweight aggregate concrete, slabs perforated by openings in the vicinity of columns, slabs with column capitals and/or drop panels, prestressed slabs, etc. Its treatment of eccentric loading covers connections between slabs and edge columns (including columns at external corners) and interior columns.

The basic method of allowing for the effect of eccentricity of loading is to calculate the nominal shear stress at the perimeter  $u_1$  due to the shear force  $V_E$  as:

$$v_v = V_E / u_1 d \quad \dots (7)$$

and the shear stress resulting from the transfer moment  $M_E (= V_E \cdot e_x)$  where  $e_x$  is the eccentricity of loading measured from the centre of gravity of  $u_1$  as:

$$v_m = K M_E / W_1 d \quad \dots (8)$$

$K$  is a coefficient depending on the shape of the column and is 0.6 for a square or circular column

$$W_1 = \int_0^u |e| d1$$

$d1$  is a length increment of the perimeter  $e$  is the distance of  $d1$  from the axis, through the centre of gravity of  $u_1$ , about which  $M_E$  acts

The maximum shear stress at  $u_1$  is then  $v_E = v_v + v_m$  or

$$v_E = \beta \frac{V_E}{u_1 d} \quad \text{with } \beta = 1 + K \frac{M_E}{V_E} \cdot \frac{u_1}{W_1}$$

This value of  $\beta$ , determined for  $u_1$ , is used unchanged for calculations at both  $u_o$  and  $u_{out}$ . In analysing test results, the experimental load  $V_{test}$  is multiplied by  $\beta$  and then compared with the resistances given by equations (1) to (6), or alternatively  $V_{test}$  can be compared with the resistance from equations (1) to (6) divided by  $\beta$ .

The general applicability of EC2, with  $V_{R,CS}$  expressed as in the code, to the design of concentrically loaded connections between slabs and interior columns using double headed studs is fairly well established. The applicability of EC2 provisions for eccentrically loaded interior and exterior column connections is not so well proven, but, assuming the code provisions to be generally appropriate, there is no apparent reason to doubt their validity for slabs reinforced with studs. Thus, although additional tests for many types of connections would be desirable, there seemed to be no pressing need for new tests related to the applications referred to above.

However there appeared to be a complete lack of information, from codes and from tests, concerning the design of connections between slabs and columns at re-entrant (or internal) corners. Thus, in the evaluation of Shearfix, it was decided to make tests on such connections to provide information on their behaviour, at the same time as validating the ability of Shearfix studs to develop the characteristic stresses of EC2 design.



## 6.2 Tests of Slab-Column Connections at Re-entrant Corners

Although EC2 does not include any rules for connections between slabs and columns at re-entrant (internal) corners, its basic treatment of eccentric loading can be extended to include this case and Fig 4 illustrates such an extension for a square column with equal transfer moments in the x and y directions.

In the course of this CARES approval, tests were made on three slabs with the dimensions shown in Fig 5. Two of the slabs were reinforced with different arrangements of Shearfix studs and the third was without shear reinforcement. Fig 6 shows the reinforcement of one of the test specimens.

The ratios of the experimental ultimate loads to the predicted strengths calculated on the basis of equations (1) to (6) and with  $\beta$  determined as above, were 1.05 for the slab without shear reinforcement and 1.10 and 1.19 for the slabs with shear reinforcement. The stronger of the slabs with shear studs carried a load 1.78 times the calculated capacity of an otherwise similar slab without shear reinforcement.

In both tests, strain measurements showed that the average stud stresses in the critical region reached  $f_{yw,eff}$  and that individual studs reached yield, even though the slab depth was the minimum for which EC2 permits the use of shear reinforcement in slabs.

The use of an approximate value for  $\beta$ , along the lines of EC2's section 6.4.3 (5), cannot be recommended for re-entrant corners, and it seems necessary for transfer moments obtained from the slab's structural analysis to be used in the design for punching.

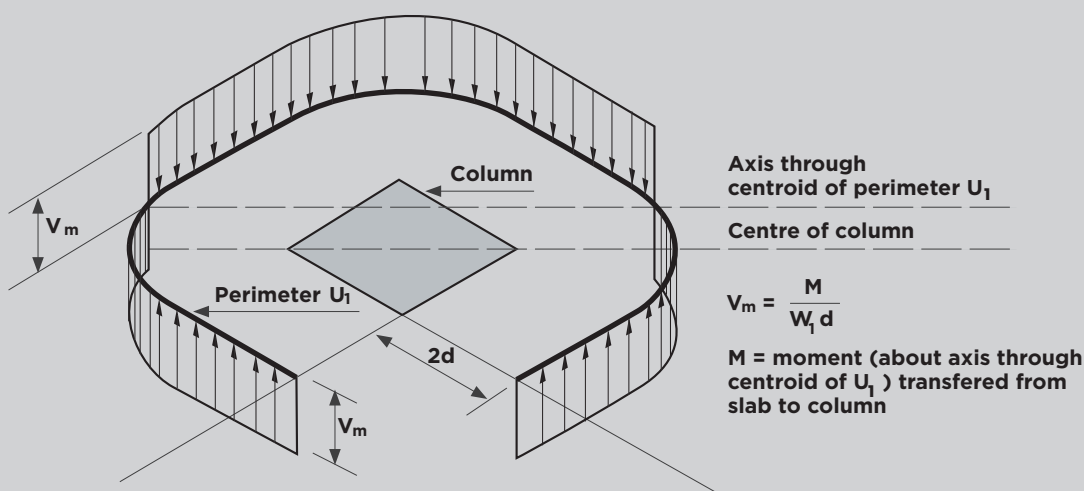

Figure 4 - Distribution of shear due to moment transfer

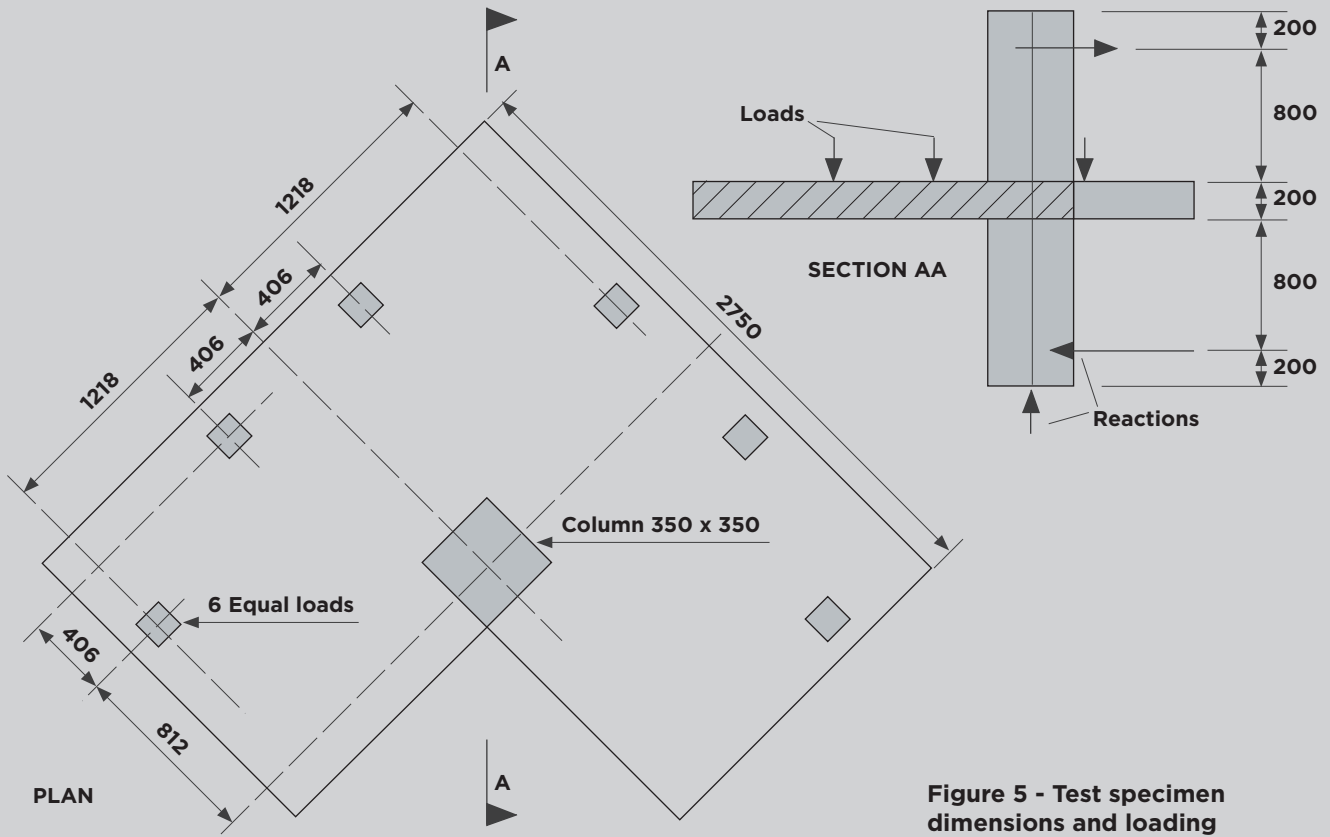

Figure 5 - Test specimen dimensions and loading

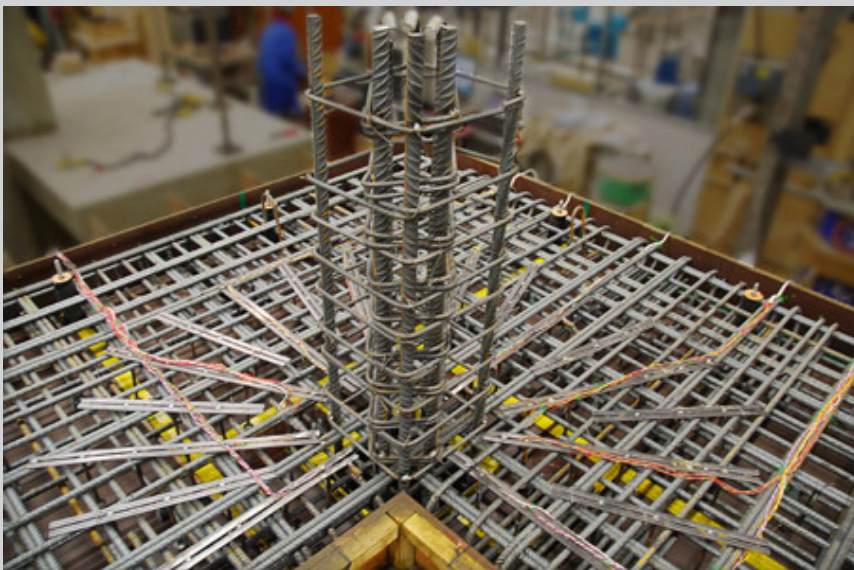

Figure 6 - SHEARFIX validation tests at Cambridge University

TECHNICAL APPROVAL 5041

UKAS PRODUCT CERTIFICATION 0002

Validate with the CARES Cloud App

Electronic Copy www.carescertification.com

## 7 Quality Assurance

Ancon Shearfix Punching Shear Reinforcement systems are provided under an ISO 9001 Quality Management. The Quality Management systems monitors the production of the Shearfix system and ensures that the materials used and the geometry remain within the limits of this technical approval.

CARES: Quality Management System Certificate No. 5041.

## 8 Building Regulations

### 8.1 The Building Regulations (England and Wales)

#### Structure, Approved Document A

Ancon SHEARFIX Punching Shear Reinforcement System, when used in EC2 based designs using the data contained within this technical approval, satisfy the relevant requirements of The Building Regulations (England and Wales), Approved Document A.

#### Materials and Workmanship, Approved Document

This technical approval gives assurance that the Ancon SHEARFIX Punching Shear Reinforcement System comply with the material requirements of EC2.

### 8.2 The Building Regulations (Northern Ireland)

#### Materials and Workmanship

This technical approval gives assurance that Ancon SHEARFIX Punching Shear Reinforcement System comply with the material requirements of EC2 by virtue of regulation 23, *Deemed to satisfy provisions regarding the fitness of materials and workmanship*.

### 8.3 The Building Standards (Scotland)

#### Fitness of Materials

This technical approval gives assurance that Ancon SHEARFIX Punching Shear Reinforcement System comply with the material requirements of EC2 by virtue of *Clause 0.8*.

#### Structure

Ancon SHEARFIX Punching Shear Reinforcement System, when used in EC2 based designs using the data contained within this technical approval, satisfy the requirements of *The Building Standards (Scotland) clause 1*.

## 9 References

- Eurocode 2 : Design of concrete structures - Part 1-1: General rules and rules for buildings, BSEN 1992-1-1:2004.
- NA to BS EN 1992-1-1:2004. UK National Annex to Eurocode 2: Design of concrete structures. General rules and rules for buildings.
- CARES Appendix TA7 Quality and Operations Schedule for the Technical Approval of Stud Shear Reinforcing Systems for Flat Slabs.
- BS4449:2005+A3:2016: Steel for the reinforcement of concrete. Weldable reinforcing steel. Bar, coil and decoiled product. Specification.
- BS EN ISO 9001:Quality Management Systems. Requirements.
- BS8110: Part 1: 1997: Structural Use of Concrete, Code of Practice for Design and Construction.
- BSEN 10025-1: 2004 Hot rolled products of structural steels.

Electronic Copy www.carescertification.com





## 10 Conditions

1. The quality of the materials and method of manufacture have been examined by CARES and found to be satisfactory. This technical approval will remain valid provided that:
  - a) The product design and specification are unchanged.
  - b) The materials, method of manufacture and location are unchanged.
  - c) The manufacturer complies with CARES regulations for Technical Approvals.
  - d) The manufacturer holds a valid CARES Certificate of Product Assessment.
  - e) The product is installed and used as described in this report.
2. CARES make no representation as to the presence or absence of patent rights subsisting in the product and/or the legal right of Leviat to market the product.
3. Any references to standards, codes or legislation are those which are in force at the date of this certificate.
4. Any recommendations relating to the safe use of this product are the minimum standards required when the product is used. These requirements do not purport to satisfy the requirements of the Health and Safety at Work act 1974 or any other relevant safety legislation.
5. CARES does not accept any responsibility for any loss or injury arising as a direct or indirect result of the use of this product.
6. This Technical Approval Report should be read in conjunction with CARES Certificate of Product Assessment No 5041. Confirmation that this technical approval is current can be obtained from CARES.



Electronic Copy www.carescertification.com

## CARES

Pembroke House  
21 Pembroke Road  
Sevenoaks  
Kent TN13 1XR

Phone: +44(0)1732 450000  
E-mail: [general@carescertification.com](mailto:general@carescertification.com)  
[www.carescertification.com](http://www.carescertification.com)



**Independent Product Assessments  
for the Construction Industry**

Copyright CARES ©