

# CARES Technical Approval Report TA1-B 5015

Issue 3



## Ancon<sup>®</sup>

**Ancon  
Tapered Thread Couplers**

Assessment of the  
Ancon Tapered Thread  
Coupler Product and  
Quality System for  
Production

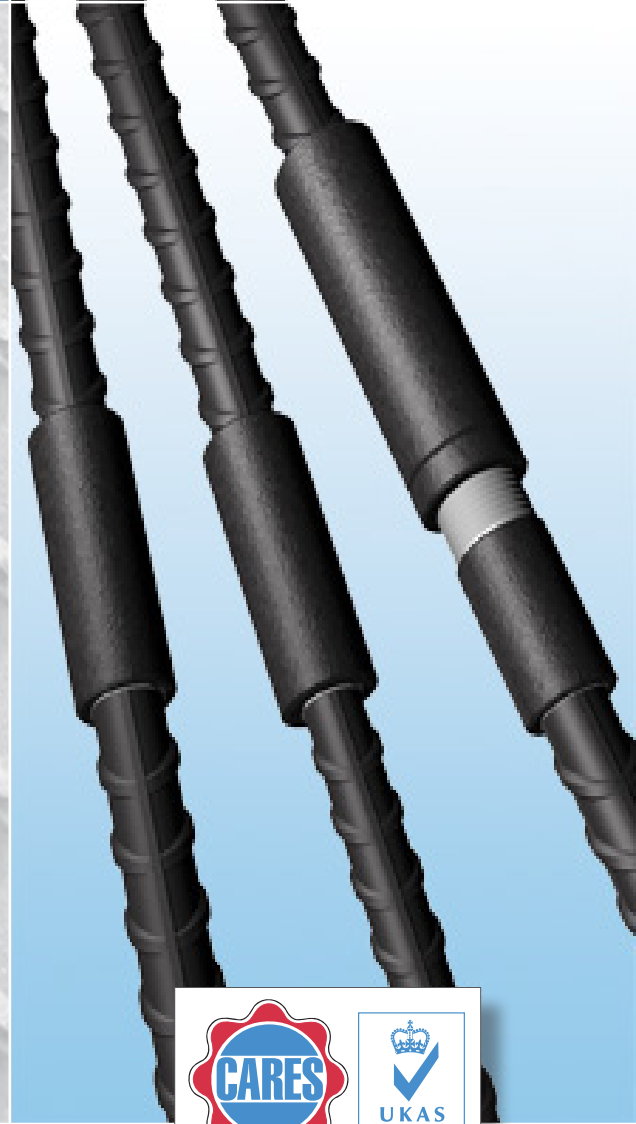

5015

Electronic Copy www.ukcares.com

# Product

Ancon standard, positional and transition mechanical couplers for reinforcing steel

## Product approval held by:

Ancon Ltd,  
President Way  
President Park  
Sheffield S4 7UR

Tel: +44 (0) 114 275 5224

Fax: +44 (0) 114 276 8543

Email: [info@ancon.co.uk](mailto:info@ancon.co.uk) Web: [www.ancon.co.uk](http://www.ancon.co.uk)

## 1 Product Summary

Ancon standard, positional and transition mechanical couplers in the size range 12mm - 50mm are for the mechanical connection of deformed high-yield carbon steel bars for the reinforcement of concrete complying with the requirements of BS4449 Grade B500B and B500C to provide jointed bars that can be subjected to tensile stress.

Ancon tapered thread couplers are steel sleeves that are used to join reinforcing bars. The coupler consists of a steel sleeve that has two internal right hand threads, which taper from each end of the sleeve towards the centre. Tapered threads are applied to the ends of the bars to be joined using a tapered threading machine.

### 1.1 Scope of Application

Ancon standard, positional and transition mechanical couplers in the size range 12mm - 50mm have been evaluated for use as follows:

- a) TA1-B: Eurocode 2 and BS 8110 for static applications in tension only with BS4449 Grades B500B & B500C reinforcement.
- b) BS8597:2015 for mechanical splices in reinforced concrete structures under predominantly static loads in tension only using BS4449 Grades B500B & B500C reinforcement.

### 1.2 Design Considerations

BS 8110 Clause 3.12.8.9 Laps and Joints states "Connections transferring stress may be lapped, welded or joined with mechanical devices. They should be placed, if possible, away from points of high stress and should preferably be staggered". However, BS 8110 Clause 3.12.8.16.2 Bars in tension states "The only acceptable form of full-strength butt joint for a bar in tension comprises a mechanical coupler" satisfying specified slip and tensile strength criteria.

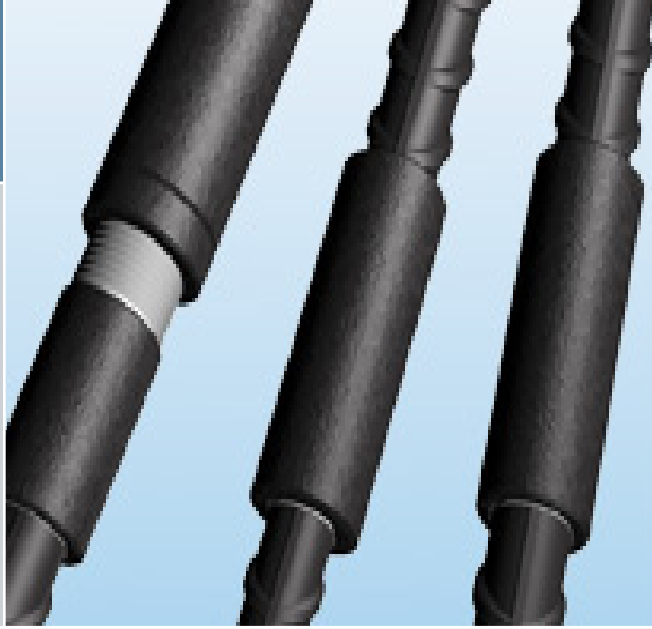

Eurocode 2, Clause 8.7 Laps and mechanical couplers 8.7.1 General (1)P "Forces are transmitted from one bar to another by:

- lapping of bars, with or without bends or hooks;
- welding;
- mechanical devices assuring load transfer in tension-compression or in compression only."

Clause 8.8 Additional rules for large diameter bars goes on to state that "Splitting forces are higher and dowel action is greater with the use of large diameter bars. Such bars should be anchored with mechanical devices."

The specified cover for fire resistance and durability should be provided to the coupler sleeve. All couplers have been designed with controlled mechanical properties to be compatible with reinforcing bars complying with reinforcement of the relevant Grade in accordance with BS4449.

### 1.3 Conclusion

It is the opinion of UK CARES that Ancon standard, positional and transition mechanical couplers in the size range 12mm - 50mm are satisfactory for use within the stated limits in paragraph 1.1 when applied and used in accordance with the manufacturer's instructions and the requirements of this certificate.

*Lee Brankley*

L. Brankley  
Chief Executive Officer

January 2019



## 2 Technical Specification

The Ancon tapered thread coupler comprises a steel sleeve that is internally threaded from both ends. The two right hand threads taper towards the centre of the tube. Tapered thread couplers are available in three types:

### 2.1 Standard Range

The standard coupler comprises an internally threaded sleeve with two right hand threads. It is used to join bars of the same diameter when the continuation bar is free to be rotated.

#### Standard Coupler

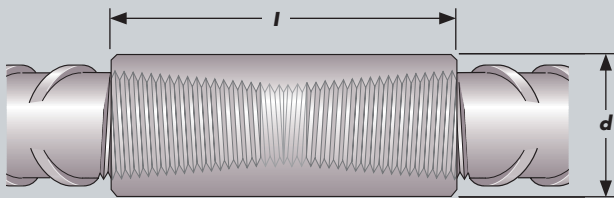

Bar Diameter		12	16	20	25	32	40	50
External Dia.	$d$	22	25	30	36	48	60	70
Coupler Length	$l$	58	70	74	90	112	138	170
Weight (kg)		0.13	0.17	0.25	0.43	0.99	1.90	2.91
Torque (Nm)		60	110	165	265	285	330	350
Part No.		TTS12	TTS16	TTS20	TTS25	TTS32	TTS40	TTS50

Table 1

## 2.2 Positional Range

The positional coupler comprises a female section, a male section and a locknut. It is designed to join reinforcing bars of the same diameter where neither bar is free to turn.

### Positional Coupler

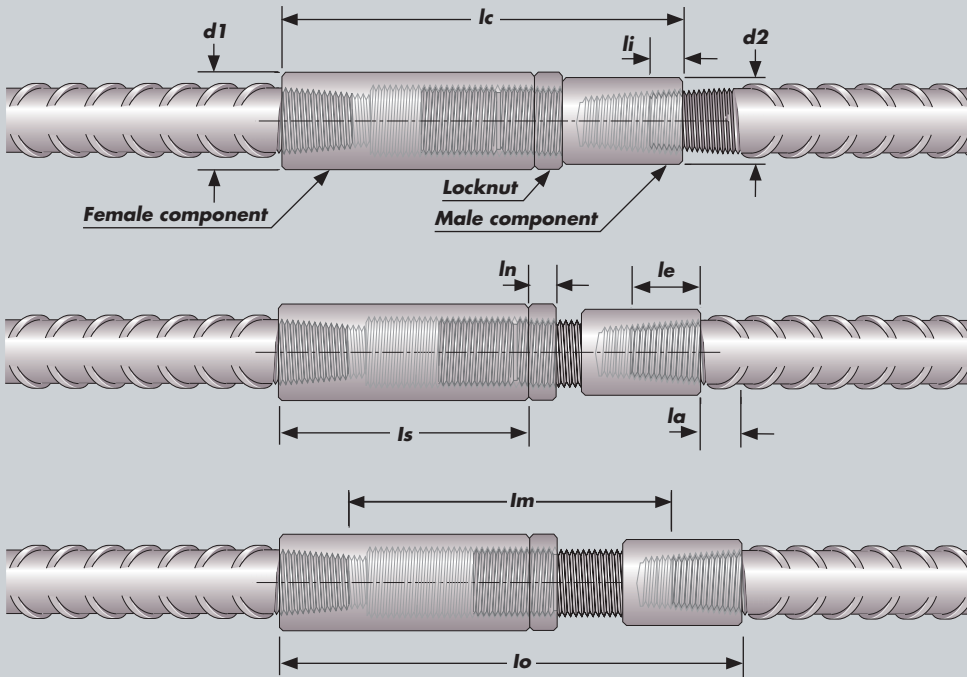

Bar Diameter		12	16	20	25	32	40	50
External Dia.	$d_1$	25	30	36	48	55	70	85
External Dia.	$d_2$	22	25	30	36	48	60	70
Female Sleeve Length	$l_s$	84	95	112	132	153	190	233
Locknut Length	$l_n$	13	13	13	13	15	15	16
Closed Length	$l_c$	138	155	180	207	243	296	359
Max. Open Length	$l_o$	178.5	196.5	231.5	266.5	305.5	374.5	454.5
Bar Insertion Prior to Engagement	$l_i$	9	15	8	16	28	40	54
Bar Insertion Full Engagement	$l_e$	26	32	33	42	53	66	82
Adjustable Length	$l_a$	23.5	24.5	26.5	33.5	37.5	52.5	67.5
Max. Distance between Bar Ends	$l_m$	126.5	132.5	165.5	182.5	199.5	242.5	290.5
Weight (kg)		0.44	0.67	1.12	2.21	3.51	6.91	11.96
Coupler Torque (Nm)		60	110	165	265	285	330	350
Locknut Torque (Nm)		20	30	50	70	90	110	130
Part No.		TTP12	TTP16	TTP20	TTP25	TTP32	TTP40	TTP50

Table 2

## 2.3 Transition Range

The transition coupler joins bars of different diameters. The sleeve includes two right hand threads that taper towards the centre of the coupler. The maximum diameter of each thread corresponds to the size of the bar to be joined. The continuation bar must be free to rotate.

### Transition Coupler

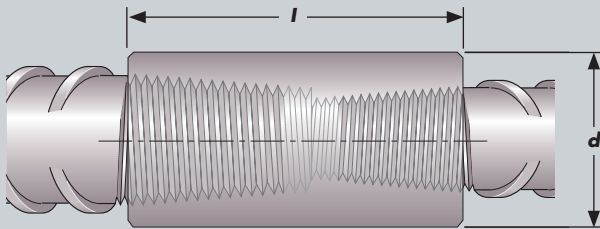

Bar Diameter		12/16	16/20	20/25	25/32	32/40	40/50
External Dia.	$d$	25	30	36	48	55	70
Coupler Length	$l$	72	78	90	112	138	170
Weight (kg)		0.21	0.30	0.48	1.11	1.62	3.31
Torque (Nm)		60/110	110/165	165/265	265/285	285/330	330/350
Part No.		TTT12/16	TTT16/20	TTT20/25	TTT25/32	TTT32/40	TTT40/50

Table 3

## 3 Product Performance and Characteristics

Mechanical tests have been carried out to demonstrate compliance with performance requirements defined in CARES Appendix TA1-B including the performance requirements of BS8110 when used with reinforcing steel BS4449 Grade B500B & B500C.

### CARES APPENDIX TA1-B requirements

- Permanent deformation is less than 0.10mm after loading to  $0.65 Re_{(char)}$  (characteristic yield strength of the bar) in tension with BS4449 Grade B500B & B500C reinforcement.
- 99% characteristic tensile strength is greater than 540MPa for grade B500B and 575MPa for grade B500C.

## 4 Installation

The ends of the bars to be threaded must be square cut using a saw or a suitable shear. Shears that bend the bar, deform the bar or leave a significant rag are unsuitable. The bar must be threaded by a suitably trained and qualified operative. The qualification of the operative will be given following training and assessment by an Ancon technician. The length of the thread is determined by using ring gauges supplied with each threading machine which are referred to in Section 7 of the Ancon Operating Manual. The installation procedures are as follows:

### 4.1 Standard and Transition Ranges

Couplers are normally supplied fixed to a reinforcing bar which has been threaded to suit the coupler. In the case of the transition range the coupler is usually supplied fixed to the larger diameter bar (see note on page 8). Place the continuation bar into the coupler and rotate until the bar threads are engaged. Continue to screw the bar into the coupler until tightened. To ensure correct installation, tighten the joint to the specified torque using a calibrated torque wrench on the continuation bar. The joint is now complete. The installation procedures can be found in the Operating Manual, Section 14.

### 4.2 Positional Range

Positional couplers are generally supplied fitted to reinforcing bar. The female section and bar are normally cast flush in the concrete. The male section and the locknut can then be screwed into the female section ready to accept the continuation bar.

Position the continuation bar into, or as near as possible to, the male section. Run the male component and locknut onto the continuation bar until fully engaged. Using a torque wrench tighten the male component to the specified torque on the continuation bar, whilst holding the continuation bar with a second wrench. Run the locknut along the threaded barrel of the male component to abut the female section. Using a torque wrench tighten the locknut to the specified torque.

At this point the groove in the parallel threaded section of the male component must be completely covered by the locknut. If any part of the groove is visible beyond the locknut, the degree of adjustability has been exceeded and the installation is incorrect.

The installation procedures can be found in the Operating Manual, Section 14.



## Standard Coupler

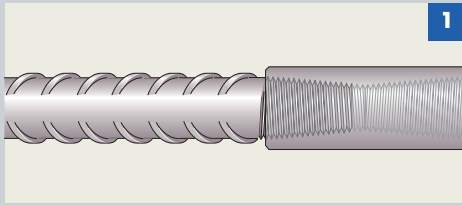

1. The coupler is normally supplied fixed to a reinforcing bar

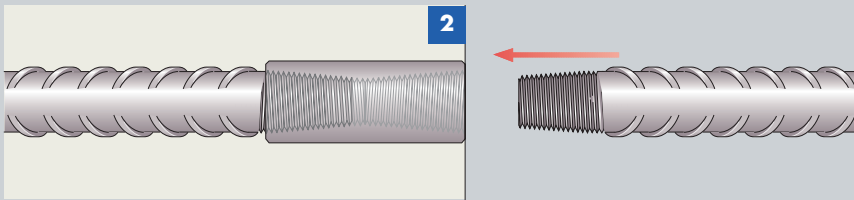

2. Position the continuation bar in the sleeve and rotate the bar into the coupler

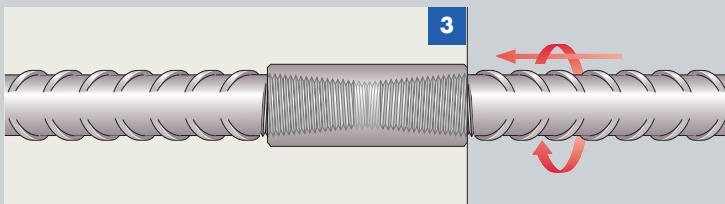

3. Continue to screw the bar into the coupler until tightened

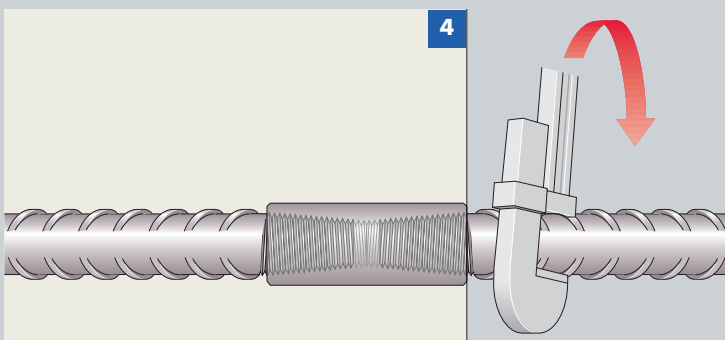

4. In order to ensure correct installation, tighten the joint to a specified torque using a calibrated torque wrench on the continuation bar.



## Transition Coupler

NOTE: In the event of the coupler being supplied fixed to the smaller bar it is necessary to ensure that when tightening the larger continuation bar, the force is not transmitted through to the smaller bar.

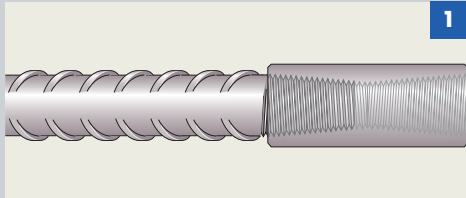

1. The coupler is normally supplied fixed to the larger reinforcing bar

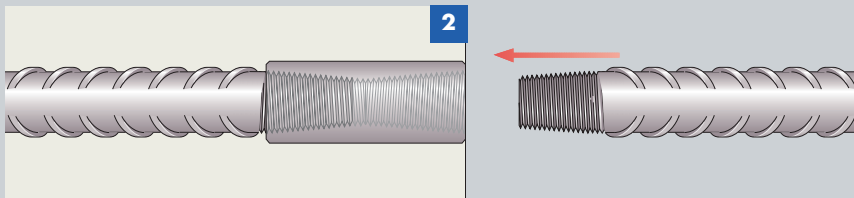

2. Position the continuation bar in the sleeve and rotate the bar into the coupler

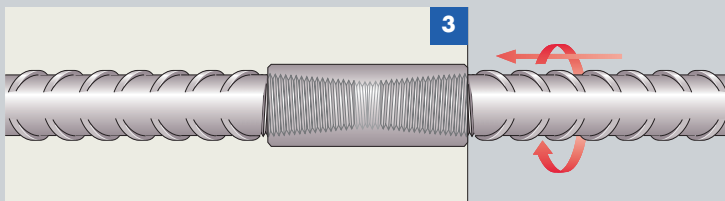

3. Continue to screw the bar into the coupler until tightened

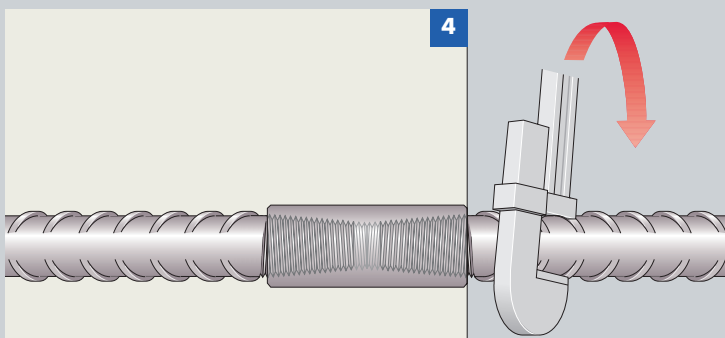

4. In order to ensure correct installation, tighten the joint to the specified torque using a calibrated torque wrench on the continuation bar

## Positional Coupler

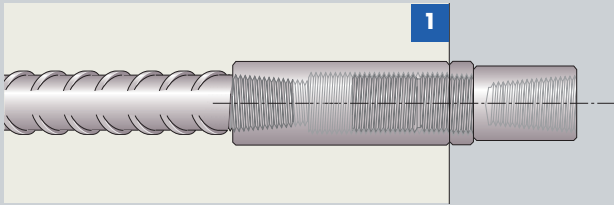

1. The female section of the positional coupler is normally cast flush in the concrete. The male end and the locknut can then be screwed into place

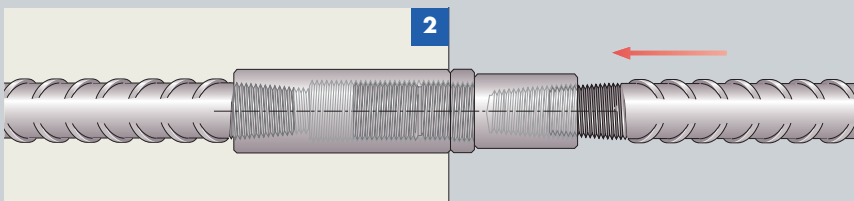

2. Position the continuation bar as near as possible to the coupler fitted to the cast-in bar

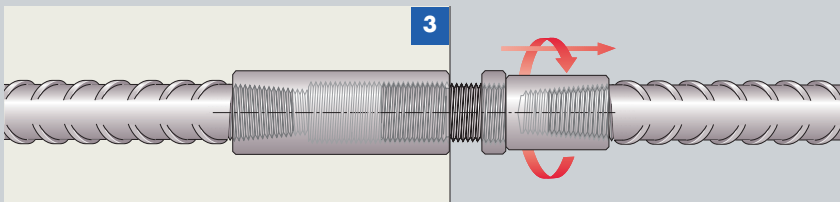

3. Run the male component and locknut onto the continuation bar until fully engaged

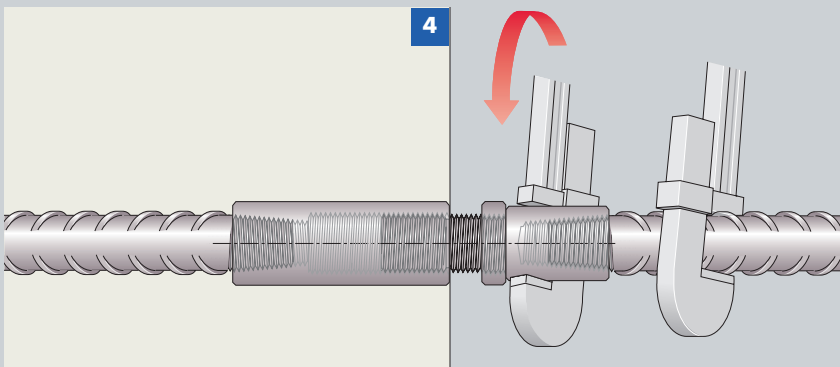

4. Using a torque wrench tighten the male component on the continuation bar to the specified torque, whilst holding the continuation bar with a second wrench

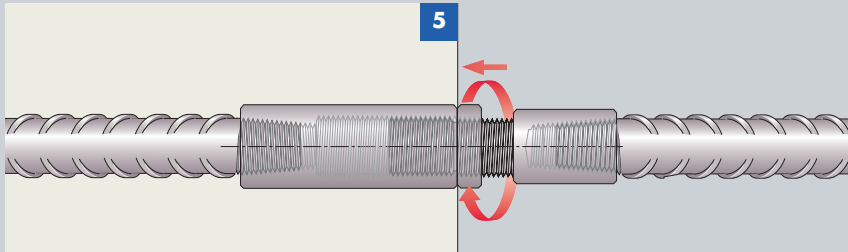

5. Run the locknut along the threaded barrel of the male component to abut the female section

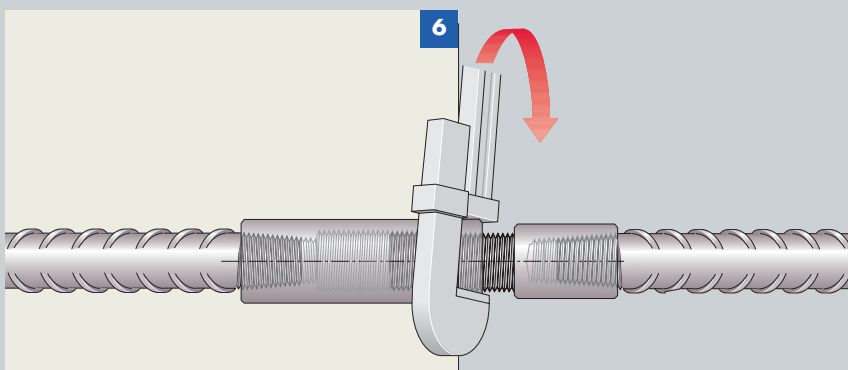

6. Using a torque wrench tighten to the specified torque

**Correct Installation**



Groove is completely hidden within locknut

**Incorrect Installation**



Groove is protruding from locknut

At this point the groove in the parallel threaded section of the male component must be completely covered by the locknut. If any part of the groove is visible beyond the locknut, the degree of adjustability has been exceeded and the installation is incorrect



## 5 Safety Considerations

Ancon tapered thread couplers are generally supplied in robust cardboard cartons. Containers weighing up to 25kg may be handled manually with care. Heavier cases require the use of mechanical handling equipment. Protective gloves should be worn when installing the couplers.

## 6 Product Testing and Evaluation

Ancon tapered thread couplers have been tested to satisfy the requirements of CARES Appendix TA1-B for couplers with reinforcing bars to BS4449 Grade B500B or B500C.

The testing comprised the following elements:

- 1 TA1-B, BS8110 and EC2
  - Tensile Strength
  - Permanent Deformation

Tests verify compliance with Clause 5 of BS 8597;2015 for both slip under static forces and tensile strength under static forces.

## 7 Quality Assurance

Ancon tapered thread couplers are produced under an BS EN ISO 9001 Quality Management System quality Assurance system certified by CARES at locations agreed with CARES. The quality assurance scheme monitors the production of the couplers and ensures that the materials and geometry remain within the limits of this technical approval.

The product is subject to a programme of periodic testing to ensure continued compliance with the performance requirements of TA1-B.

## 8 Building Regulations

### 8.1 The Building Regulations (England and Wales)

#### Structure, Approved Document A

Ancon tapered thread couplers, when used in EC2 based designs using the data contained within this technical approval, satisfy the relevant requirements of The Building Regulations (England and Wales), Approved Document A.

#### Materials and Workmanship, Approved Document

This technical approval gives assurance that the Ancon tapered thread couplers comply with the material requirements of EC2.

### 8.2 The Building Regulations (Northern Ireland)

#### Materials and Workmanship

This technical approval gives assurance that Ancon tapered thread couplers comply with the material requirements of EC2 by virtue of regulation 23, *Deemed to satisfy provisions regarding the fitness of materials and workmanship*.

### 8.3 The Building Standards (Scotland)

#### Fitness of Materials

This technical approval gives assurance that Ancon tapered thread couplers comply with the material requirements of EC2 by virtue of *Clause 0.8*.

#### Structure

Ancon tapered thread couplers, when used in EC2 based designs using the data contained within this technical approval, satisfy the requirements of *The Building Standards (Scotland) clause 1*.



## 9 References

- BS 4449: 2005: Steel for the reinforcement of concrete - Weldable reinforcing steel - Bar, coil and decoiled product - Specification
- BS 8110: Part 1: 1997 (Revised 2005): Structural Use of Concrete, Code of Practice for Design and Construction
- BS 8597:2015 Steels for the reinforcement of concrete – Reinforcement couplers – Requirements and test methods.
- BS EN 1992-1-1:2004 Eurocode 2 Design of concrete structures - General rules for buildings
- BS EN ISO 9001: Quality management systems - Requirements
- CARES Appendix TA1-B: Quality and Operations Schedule for the Technical Approval of Couplers for Reinforcing Steel and Reinforcement Anchors For BS8110 and EN1992-1-1 Static Loading in Tension or Tension and Compression

## 10 Conditions

1. The quality of the materials and method of manufacture have been examined by CARES and found to be satisfactory. This Technical Approval will remain valid provided that:
  - a) The product design and specification are unchanged.
  - b) The materials, method of manufacture and location are unchanged.
  - c) The manufacturer complies with CARES regulations for Technical Approvals.
  - d) The manufacturer holds a valid CARES Certificate of Product Assessment.
  - e) The product is installed and used as described in this report.
2. CARES make no representation as to the presence or absence of patent rights subsisting in the product and/or the legal right of Ancon to market the product.
3. Any references to standards, codes or legislation are those which are in force at the date of this certificate.
4. Any recommendations relating to the safe use of this product are the minimum standards required when the product is used. These requirements do not purport to satisfy the requirements of the Health and Safety at Work etc Act 1974 or any other relevant safety legislation.
5. CARES does not accept any responsibility for any loss or injury arising as a direct or indirect result of the use of this product.
6. This Technical Approval Report should be read in conjunction with CARES Certificate of Product Assessment No 5015. Confirmation that this technical approval is current can be obtained from UK CARES.



## Ancon Tapered Thread Couplers



Standard Tapered Thread Coupler

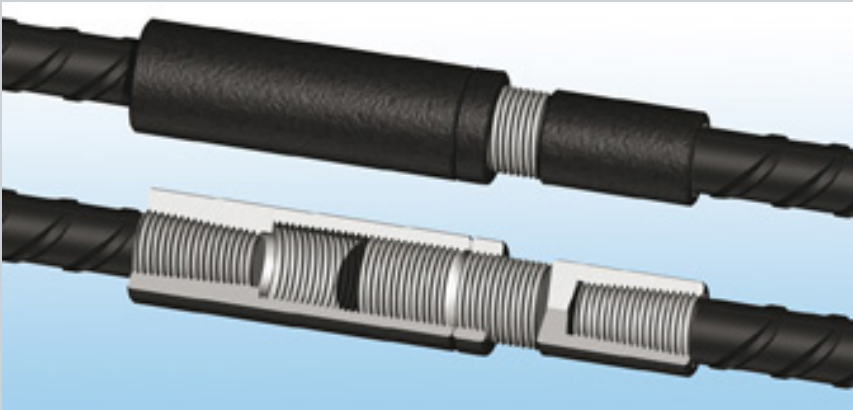

Positional Tapered Thread Coupler

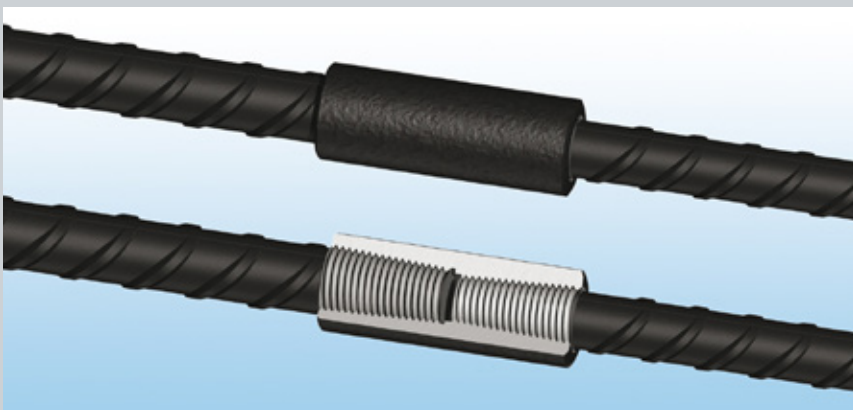

Transition Tapered Thread Coupler



## Ancon Tapered Thread Coupler Applications



Column Construction using Tapered Thread Couplers



Tapered Thread Couplers used where density of rebar creates restricted access



Pile Cage Connections

Electronic Copy www.ukcares.com





Electronic Copy www.ukcares.com



**UK CARES**

Pembroke House  
21 Pembroke Road  
Sevenoaks  
Kent TN13 1XR

Phone: +44(0)1732 450000  
Fax: +44(0)1732 455917  
E-mail: [general@ukcares.com](mailto:general@ukcares.com)  
URL: [www.ukcares.com](http://www.ukcares.com)

**Independent Product Assessments  
for the Construction Industry**

Copyright UK CARES ©