



## European Technical Assessment

**ETA-23/0276  
of 31.07.2023**

### General Part

**Technical Assessment Body issuing the European Technical Assessment:**  
LUXEMBOURG INSTITUTE FOR BUILDING AND TECHNOLOGY

**Trade name of the construction product**

**HALFEN TENSION ROD SYSTEM DETAN-D**

**Product family to which the construction product belongs**

Tension rod system

**Manufacturer**

Leviat GmbH  
Liebigstr. 14  
40764 Langenfeld  
Germany

**Manufacturing plant(s)**

Leviatwerke  
Leviat Manufacturing Plants (see control plan)

**This European Technical Assessment contains**

19 pages including 14 annexes which form an integral part of this assessment

**This European Technical Assessment is issued in accordance with Regulation (EU) No 305/2011, on the basis of**

EAD 200032-00-0602  
PREFABRICATED TENSION ROD SYSTEMS WITH SPECIAL END CONNECTORS

Translations of this European Technical Assessment in other languages shall fully correspond to the original issued document and should be identified as such.

Communication of this European Technical Assessment, including transmission by electronic means, shall be in full (excepted the confidential Annex(es) referred to above). However, partial reproduction may be made, with the written consent of the issuing Technical Assessment Body. Any partial reproduction has to be identified as such.

The European Technical Assessment is issued by the Technical Assessment Body in its official language. Translations of this European Technical Assessment in other languages shall fully correspond to the original issued document and shall be identified as such.

Communication of this European Technical Assessment, including transmission by electronic means, shall be in full. However, partial reproduction may only be made with the written consent of the issuing Technical Assessment Body. Any partial reproduction shall be identified as such.

This European Technical Assessment may be withdrawn by the issuing Technical Assessment Body, in particular pursuant to information by the Commission in accordance with Article 25(3) of Regulation (EU) No 305/2011.

## Specific Part

### 1. Technical description of the product

The construction product is a prefabricated tension rod system of different system sizes used as a kit. The tension rod system consists of stainless steel bars (tension rods) with external threads which are connected to each other and to the corresponding structure by special connecting devices. The tension rods are connected to the corresponding structure by stainless steel cast forks with two eye loops and internal thread. The forks are connected by double shear stainless steel pins connections to corresponding steel gusset plates or anchor discs. The tension rods are connected to each other by stainless steel threaded sleeves (couplers, couplers with hangers and cross couplers).

The tension rod system comprises tension rods, forks, gusset plates, anchor discs, threaded sleeves and pins with metric ISO threads M 8 to M 42. Drawings of the tension rod system and the components as well as the essential dimensions of the components are given in the Annexes to this ETA.

The dimensions, tolerances and materials of the components of the tension rod system not indicated in Annexes shall correspond to the respective values and information laid down in the technical documentation to this European technical assessment.

### 2. Specification of the intended use(s) in accordance with the applicable European Assessment Document (hereinafter EAD)

The tension rod system is intended for the use in structures with static or quasi-static loads according with EN 1990:2002, where no verification of fatigue relating to EN 1993-1-9:2005 is necessary.

The intended use comprises for instance the suspension of roof structures or vertical glazings as well as bracings and truss structures.

The tension rod system is not subjected to systematic bending.

The fork end connectors may also be connected to compression rods. The compression rods themselves are not part of the ETA.

The performances given in Section 3 are only valid if the tension rod system is used in compliance with the specifications and conditions given in Annex A and Annexes B1 to B9.

According to EAD 200032-00-0602 a working life of the tension rod systems of at least 25 years is assumed. The indications given on the working life cannot be interpreted as a guarantee given by the manufacturer, but are to be regarded only as a means for choosing the right products in relation to the expected economically reasonable working life of the works.

### 3. Performance of the product and references to the methods used for its assessment

#### 3.1 Mechanical resistance and stability (BWR 1)

##### 3.1.1 Fork, pin, lock cover, anchor disc, coupler, gusset plate

Essential characteristic	Performance
Geometry incl. tolerances	See Annexes B2 to B9 and control plan
Dimensions incl. tolerances	See Annexes B2 to B9 and control plan
Thread incl. tolerances	See Annex B2 to B3 and control plan
Material	See Annex B10
Load bearing capacity	See Annex B11 The load bearing capacity of the gusset plate is not part of this ETA.
Resistance to corrosion	See Annex B10

##### 3.1.2 Tension rod

Essential characteristic	Performance
Nominal rod diameter	See Annex B2
Thread incl. tolerances	See Annex B2 to B3 and control plan
Yield strength	See Annex B10
Tensile strength	See Annex B10
Material	See Annex B10
Tension resistance	See Annex B11
Compression force	See Annex A
Resistance to corrosion	See Annex B10

#### 3.2 Safety in case of fire (BWR 2)

Tension rod, fork, pin, anchor disc, coupler, gusset plate

Essential characteristics	Performance
Reaction to fire	Class A1 according with EN 13501-1:2007+A1:2009
Resistance to fire	NPD <sup>*)</sup>

<sup>\*)</sup> The tension rod system is considered to satisfy the requirements for performance class A1 of the characteristic reaction to fire in accordance with the EC Decision 9/603/EC, amended by EC decision 2000/605/EC and EC decision 2003/424/EC without need for testing on the basis of it fulfilling the conditions set out in that Decision and its intended use being covered by that Decision.

**3.3 Safety and accessibility in use (BWR 4)**

Same as BWR 1.

**4. Assessment and verification of constancy of performance (hereinafter AVCP) system applied, with reference to its legal base**

In accordance with European Assessment Document EAD No. 200032-00-0602, the applicable European legal act is: 98/214/EC.

The system to be applied is: 2+

**5. Technical details necessary for the implementation of the AVCP system, as provided for in the applicable EAD**

Technical details necessary for the implementation of the AVCP system are laid down in the control plan deposited with LUXIB.

Issued in Luxembourg on 31.07.2023 by Luxembourg Institute for Building and Technology



Thierry Kohnen  
General Manager

## Annex A

### A.1 Assumptions concerning design

The design of the tension rod system is carried out under the following conditions:

The loading is static or quasi-static according with EN 1990:2002 without need of verification of fatigue relating to EN 1993-1-9:2005. The tension rod systems are not used, when constructions are susceptible to vibrations under wind loads or wind-induced cross vibrations of the entire construction appear.<sup>1</sup>

Dimensions, material properties and screw-in lengths given in Annex B are observed. The tension rod system is not subjected to systematic bending. The verification concept stated in EN 1990:2002 as well as the design values of resistance stated below are used for design. The rules given in EN 1090-2:2018 are taken into account. Design is carried out by the designer of the structure experienced in the field of steel structures.

#### Design tension resistance of the entire tension rod system:

The design value  $F_{t,Rd}$  of the tension resistance of the entire tension rod system (tension rods, forks incl. pins, couplers and anchor discs) (excluding gusset plates) is the value of the design tension resistance  $F_{t,Rd, \text{Tension Rod}}$  of the tension rod.

The design values shall be determined according with EN 1993-1-1:2005 +AC:2009, EN 1993-1-4:2006 + A1:2015, EN 1993-1-8:2005 + AC:2009 and EAD 200032-00-0602 as follows:

$$F_{t,Rd, \text{Tension Rod}} = \min \left\{ \begin{array}{l} \frac{A \cdot f_{y,k}}{\gamma_{M0}} \\ \frac{0.9 \cdot f_{u,k}}{\gamma_{M2}} \end{array} \right\} \text{ with}$$

A = minimum value of the net cross section of the unthreaded part of the tension rod (see EN 1993-1-1:2005 + AC:2009)

A<sub>S</sub> = cross section of the threaded part of the tension rod (see EN 1993-1-8:2005 + AC:2009)

f<sub>y,k</sub> =characteristic value of the yield strength of the tension rod material according with R<sub>p0,2</sub> given in Annex B10

f<sub>u,k</sub> =characteristic value of the tensile strength of the tension rod material according with R<sub>m</sub> given in Annex B10

γ<sub>M0</sub> = 1.1 for stainless steel

γ<sub>M2</sub> = 1.25

The resulting design values of tension resistance of the entire tension rod system are summarized in Annex B11.

---

<sup>1</sup> The national provisions of the Member State applicable for the location where the product is incorporated in the works shall be taken into account.

### Design values of the system when using compression rods

The design value of the compression force  $N_{c,Rd}$  of the system in accordance with Annex A2 is the minimum value of

- the design value of the compression force of the compression rods in the cross-section of the thread  $F_{c,Rd}$  and
- the design value of the compression force of compression rods determined in accordance with EN 1993-1-1:2005 + AC:2009 and 1993-1-4:2006 + A1:2015 considering the additional bending strength in consequence of one-sided contact of the gusset plates  $N_{b,Rd}$ .

$$N_{c,Rd} = \min \left\{ \begin{array}{l} F_{c,Rd} \\ N_{b,Rd} \end{array} \right\} \text{ with}$$

$$F_{c,Rd} = \left[ \frac{\gamma_{M2}}{A_s \cdot f_{u,c}} + \frac{\left( \frac{B-t_{Gl}}{2} + \frac{H}{50} \right) \cdot \gamma_{M0}}{W_{pl,s} \cdot f_{y,c}} \right]^{-1}$$

$A_s$  = cross section of the threaded part of the tension rod  
(see EN 1993-1-8:2005 + AC:2009)

$W_{pl,s}$  = plastic section modulus of the core cross section of the thread of the compression rod

$f_{y,c}$  = characteristic value of the yield strength of the compression rod, where  
 $f_{y,c} = R_{p0,2}$  characteristic value of the yield strength of the compression rod in accordance with product standard

$f_{u,c}$  = characteristic value of the yield strength of the compression rod, where  
 $f_{u,c} = R_m$  characteristic value of the tensile strength of the compression rod in accordance with product standard

The dimensions of  $B = S2$ ,  $H = P1$  are stated in Annex B3 (S2 and P1) and Annex B9 (S3). The value  $t_{Gl}$  is the thickness of the gusset plate.

Recommended values for the partial safety factors  $\gamma_{M0}$  and  $\gamma_{M2}$  are:

$\gamma_{M0} = 1.1$  for stainless steel

$\gamma_{M2} = 1.25$

$N_{b,Rd}$  has to be calculated according to EN 1993-1-1:2005 + AC:2009 and 1993-1-4:2006 + A1:2015.

The values given for the partial safety factors  $\gamma_{M0}$  and  $\gamma_{M2}$  are recommended minimum values. They should be used in cases where no values are given in national regulations of the Member State where the tension rod system is used or in the respective National Annex to Eurocode 3.

Screw-in lengths given in Annex B3 have to be observed.

In addition EN 1993-1-1 or EN 1993-1-4 applies for verification against buckling.

## **A.2 Assumptions concerning Installation**

The installation of the tension rod system is carried out under the following conditions:

The installation is only carried out according with the manufacturer's instructions. The manufacturer hands over the assembly instructions to the assembler. From the assembly instructions it is followed that, prior to installation, all components of the tension rod system shall be checked for their perfect condition and that damaged components shall not be used.

The forks are not subjected to sudden or impact loads (for instance pins of forks may not be adjusted by hammer blows).

The minimum screw-in lengths are marked in an appropriate way. The keeping of the minimum screw-in lengths (given by corresponding holes) given in Annex B is checked by the assembler. How to do this is described in the assembly instructions. The compliance of the screw-in lengths shall be attested with a written confirmation by a person responsible for the construction site.

All relevant components shall be checked continuously regarding corrosion damage after installation. The result of the checks shall be recorded.

The conformity of the installed tension rod system with the provisions of the ETA is attested by the executing assembler.

## **A.3 Indications to the manufacturer**

The manufacturer shall ensure that the information on the specific conditions is given to those who are concerned. This information may be given by reproduction of the European Technical Assessment. In addition all essential installation data (e.g. minimum screw-in length according with Annex B3) shall be shown clearly on the package and/or on an enclosed instruction sheet, preferably using illustration(s).

The prefabricated tension rod system shall be packaged and delivered as a complete unit only (tension rods, forks incl. pins, threaded sleeve, connection discs and gusset plates).

The forks used for the connection to compression bars may also be delivered separately.



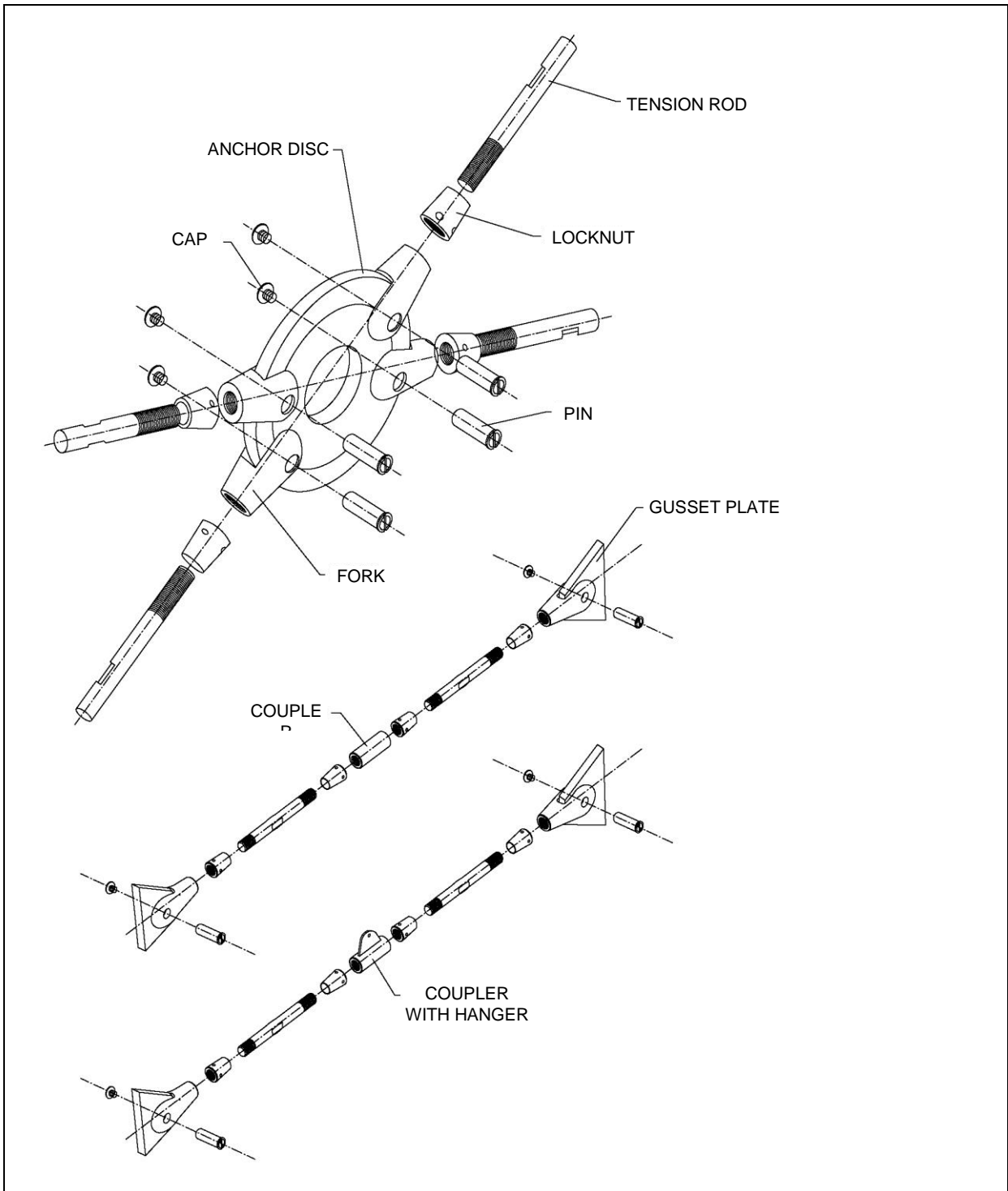

**DETAN D Tension Rod System**

System components

**Annex B1**

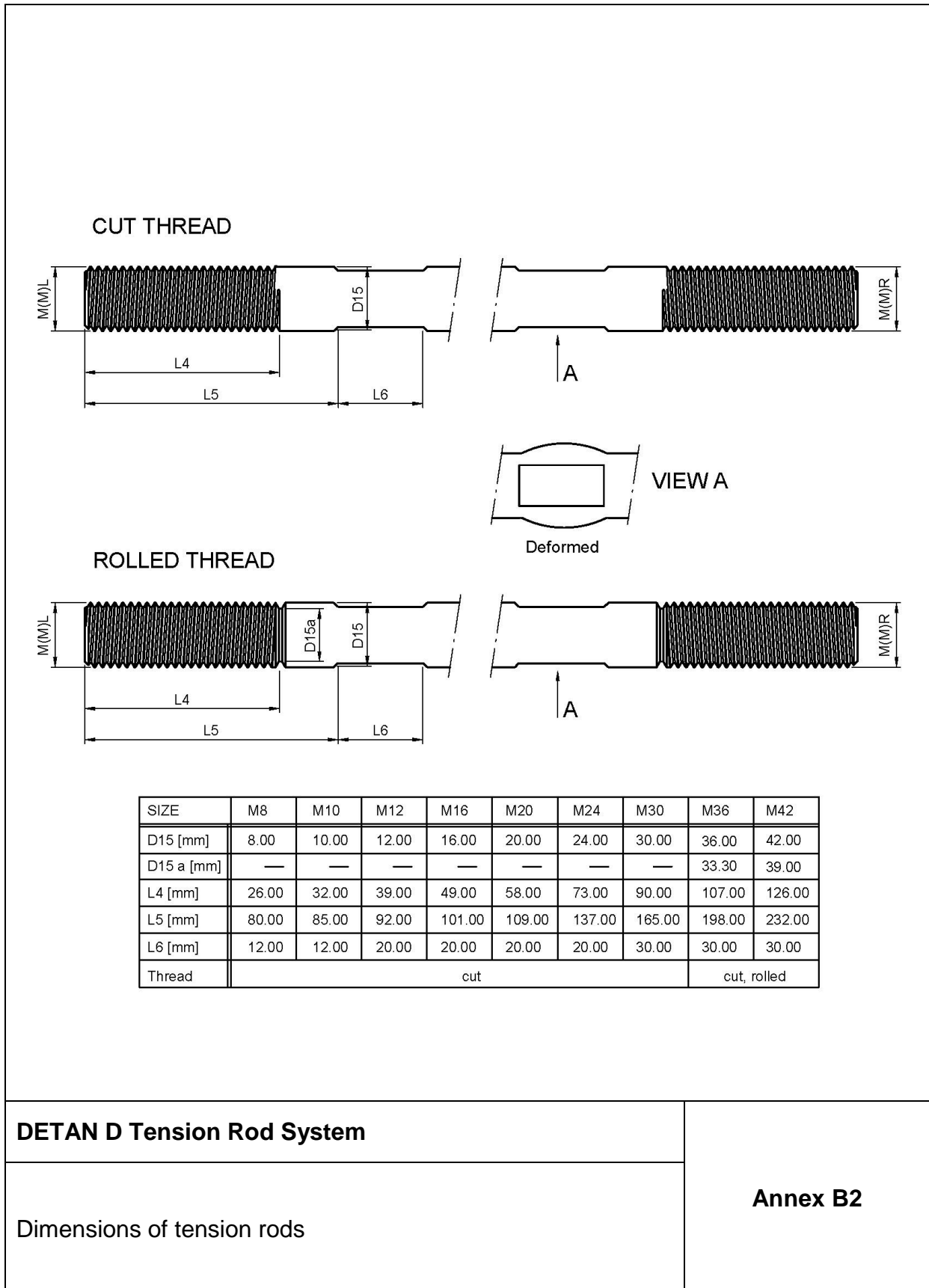

**DETAN D Tension Rod System**

Dimensions of tension rods

**Annex B2**

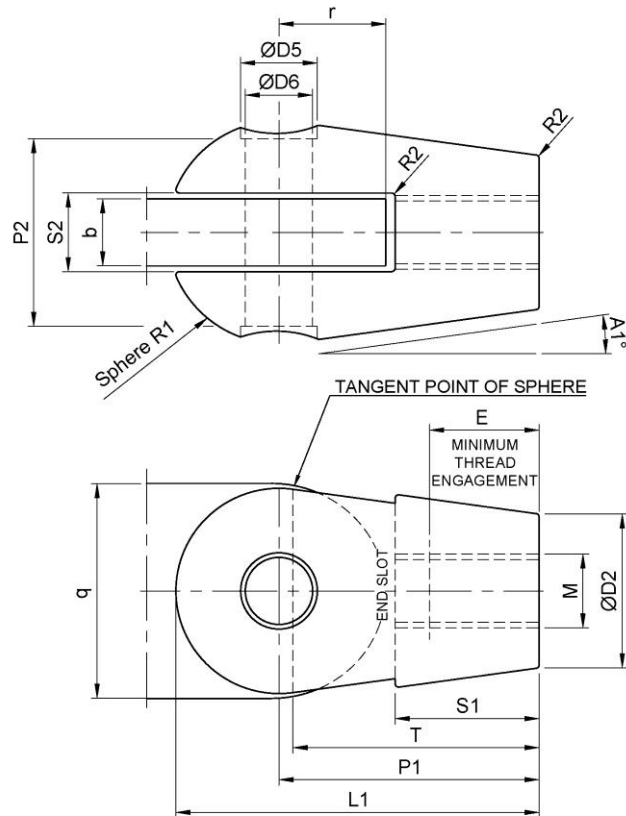

System size	M8	M10	M12	M16	M20	M24	M30	M36	M42
A1 [°]	7.36	7.70	7.37	7.82	8.38	7.44	7.90	7.78	7.66
D2 [mm]	15.85	19.95	23.78	33.27	41.40	48.99	62.16	74.46	87.00
D5 [mm]	9.50	11.00	13.50	16.50	21.00	24.50	30.00	36.75	42.75
D6 [mm]	7.50	9.50	11.50	14.50	18.50	21.50	26.50	30.50	35.50
L1 [mm]	40.55	49.39	59.65	78.19	93.86	114.51	139.89	169.11	196.04
M [mm]	M8	M10	M12	M16	M20	M24	M30	M36	M42
P1 [mm]	29.95	35.95	43.70	56.00	66.00	82.00	99.00	119.00	138.00
P2 [mm]	19.13	24.99	29.40	40.60	51.87	61.19	77.49	92.82	106.36
R1 [mm]	11.70	14.70	17.40	24.10	30.10	34.90	44.40	53.00	61.50
R2 [mm]	0.50	0.50	0.50	0.75	0.75	1.00	1.50	1.50	2.00
S1 [mm]	17.00	20.00	25.00	31.00	36.00	46.00	55.00	63.25	72.75
S2 [mm]	8.70	10.70	12.70	16.00	21.00	21.00	31.00	31.00	36.00
T [mm]	28.45	33.98	41.47	52.72	61.61	77.48	92.89	111.82	129.81
E [mm]	8	10	12	16	20	24	30	36	42
b [mm]	8	10	12	15	20	20	30	30	35
q [mm]	24	30	36	46	58	70	86	108	126
r [mm]	12	15	18	23	29	35	43	54	63

**DETAN D Tension Rod System**

Dimensions of fork heads

**Annex B3**

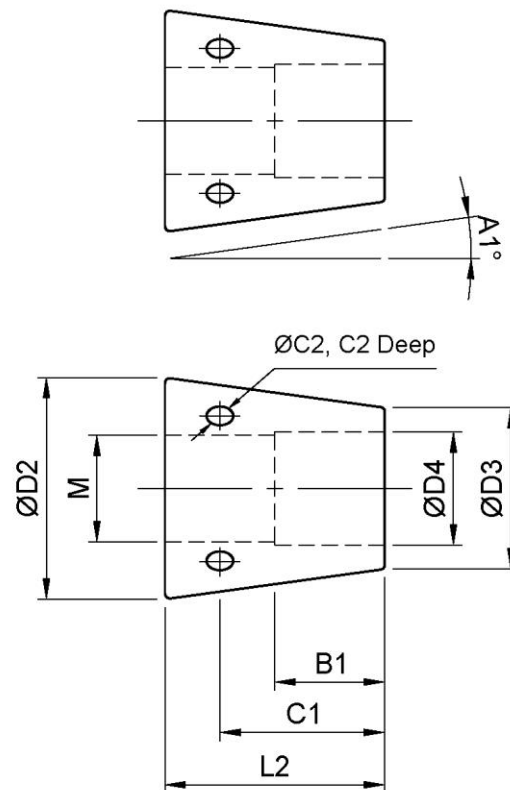

System size	M8	M10	M12	M16	M20	M24	M30	M36	M42
A1 [°]	7.36	7.70	7.37	7.82	8.38	7.44	7.90	7.78	7.66
B1 [mm]	12.50	15.00	18.20	20.00	21.00	27.00	32.50	35.50	42.00
C1 [mm]	9.83	14.80	10.87	24.75	16.29	37.55	47.77	54.68	57.97
C2 [mm]	2.00	2.50	2.50	4.50	4.50	5.50	5.50	6.50	6.50
D2 [mm]	15.85	19.95	23.78	33.27	41.40	48.99	62.16	74.46	87.00
D3 [mm]	11.20	14.00	16.80	24.20	30.20	36.20	45.50	55.05	64.41
D4 [mm]	8.50	11.00	13.00	17.00	22.00	26.00	32.00	39.00	45.00
L2 [mm]	18.00	22.00	27.00	33.00	38.00	49.00	60.00	71.00	84.00
R2 [mm]	0.50	0.50	0.50	0.75	0.75	1.00	1.50	1.50	2.00

**DETAN D Tension Rod System**

Dimensions of locknuts

**Annex B4**

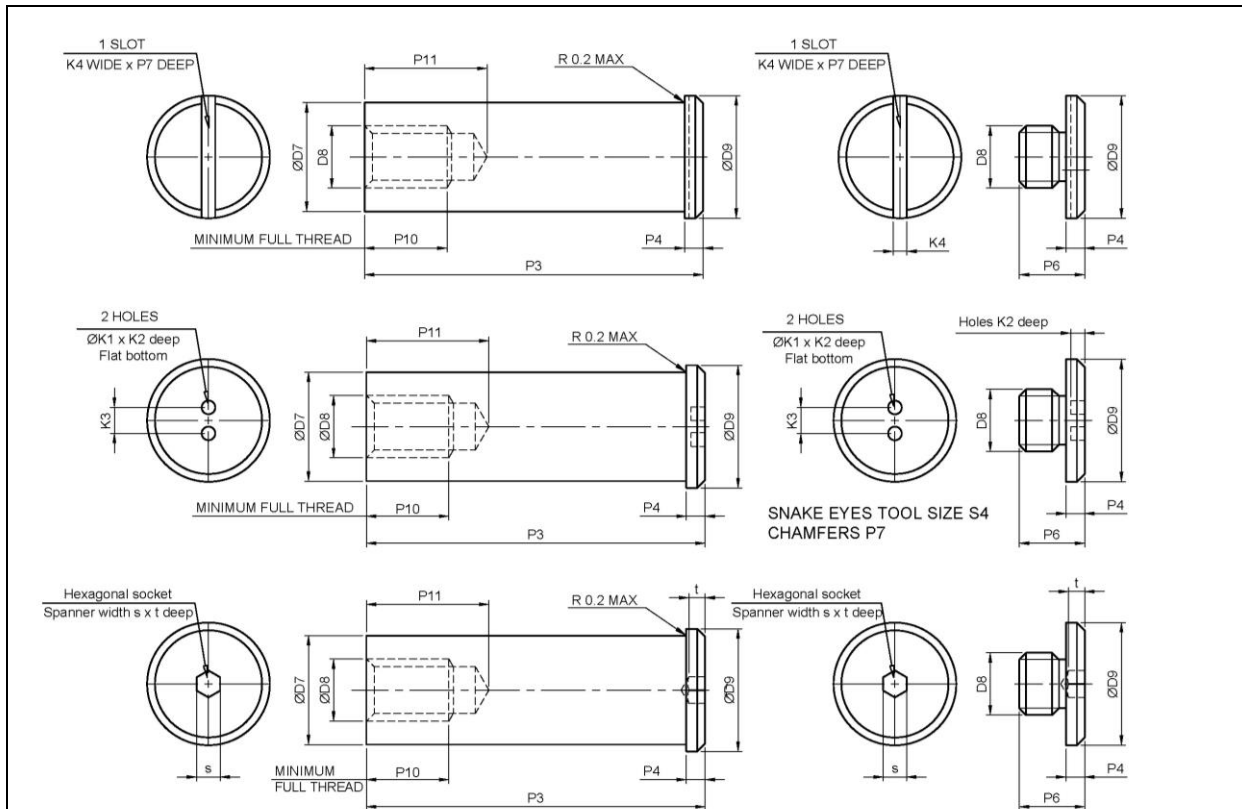

System size	M8	M10	M12	M16	M20	M24	M30	M36	M42
D7 [mm]	7.00	9.00	11.00	14.00	18.00	21.00	26.00	30.00	35.00
D8 [mm]	M5	M6	M8	M8	M10	M12	M12	M12	M12
Pitch	0.80	1.00	1.25	1.25	1.50	1.75	1.75	1.75	1.75
D9 [mm]	8.75	10.25	12.75	15.75	20.25	23.75	29.50	36.00	42.00
K1 [mm]	1.59	1.59	1.59	1.76	1.76	2.18	2.18	2.18	2.18
K2 [mm]	1.00	1.00	1.00	2.00	2.00	2.20	2.20	2.20	2.20
K3 [mm]	2.35	2.35	2.35	3.34	3.34	4.70	4.70	4.70	4.70
K4 [mm]	3.00	3.00	3.00	4.00	4.00	5.00	6.00	6.00	7.00
P3 [mm]	21.13	26.99	32.05	43.90	55.87	65.19	82.94	99.27	114.42
P4 [mm]	1.50	1.50	2.00	2.40	3.00	3.00	4.00	5.00	6.00
P6 [mm]	10.50	12.50	14.00	8.40	11.00	11.00	14.00	15.00	16.00
P7 [mm]	0.75	0.75	1.00	1.00	1.50	1.50	2.00	3.00	3.00
P10 [mm]	10.10	12.60	13.60	7.60	10.10	10.10	13.10	17.60	17.60
P11 [mm]	13.76	17.50	19.04	11.54	15.05	18.56	22.06	29.56	33.06
s [mm]	3.00	3.00	3.00	3.00	5.00	5.00	5.00	5.00	5.00
t [mm]	1.56	1.56	1.56	1.56	2.60	2.60	2.60	2.60	2.60
S4	4	4	4	6	6	10	10	10	10

**DETAN D Tension Rod System**

Dimensions of pins

**Annex B5**

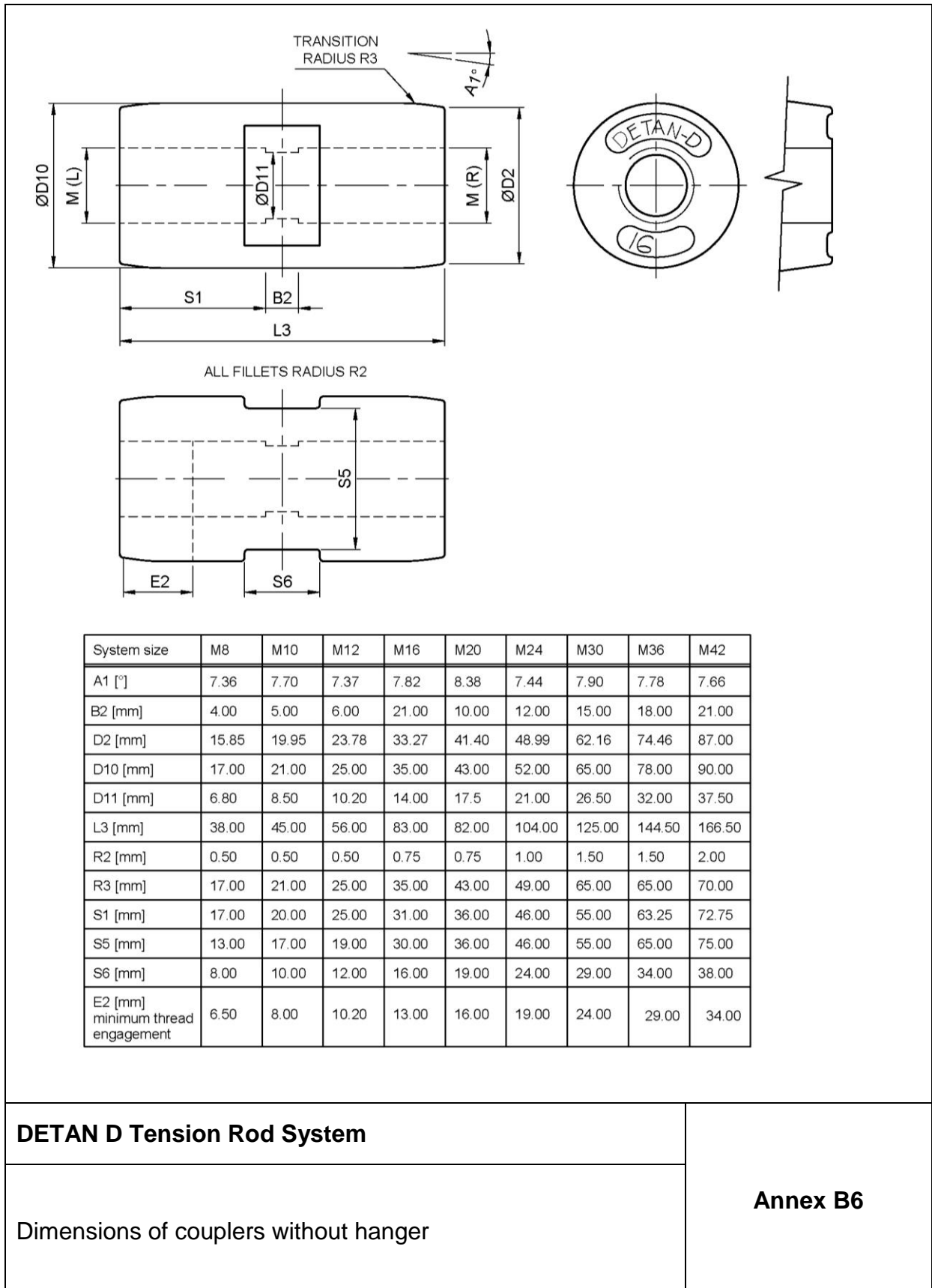



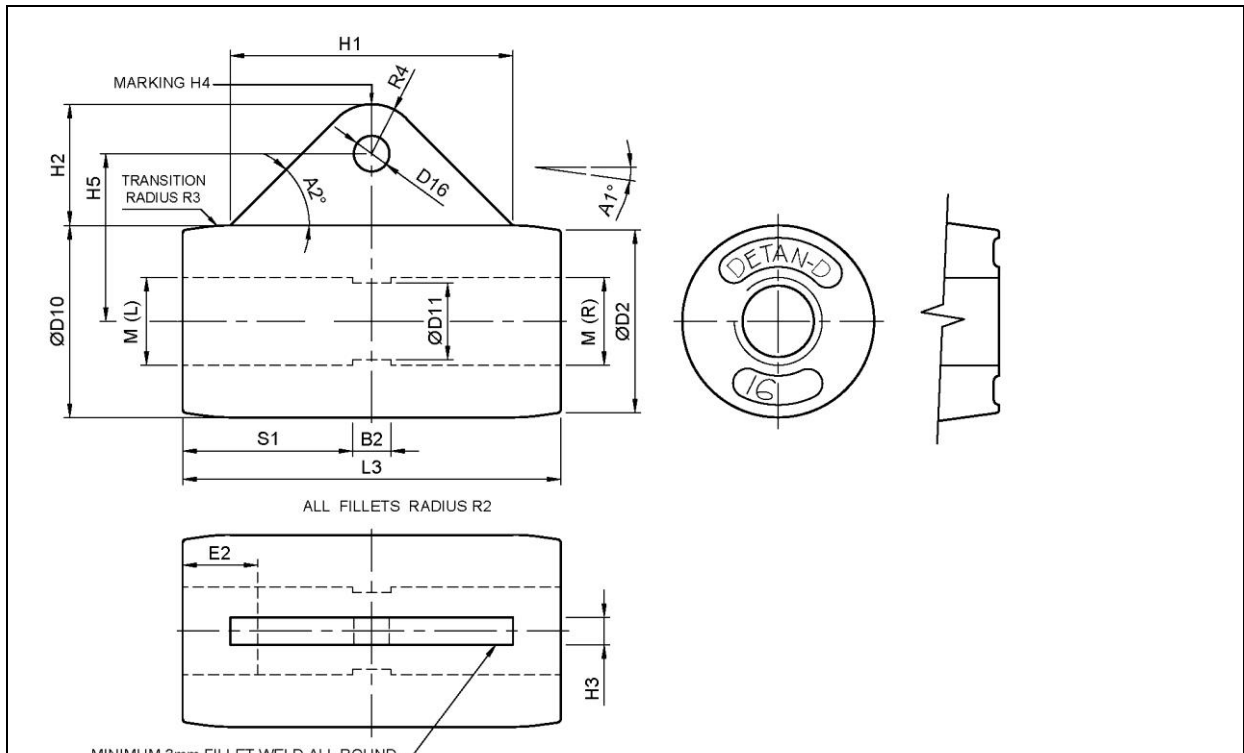

System size	M16	M20	M24	M30	M36	M42
A1 [°]	7.82	8.38	7.44	7.90	7.78	7.66
A2 [°]	45.00	45.00	45.00	45.00	45.00	45.00
B2 [mm]	21.00	10.00	12.00	15.00	18.00	21.00
D2 [mm]	33.27	41.40	48.99	62.16	74.46	87.00
D10 [mm]	35.00	43.00	52.00	65.00	78.00	90.00
D11 [mm]	14.00	17.5	21.00	26.50	32.00	37.50
D16 [mm]	7.50	7.50	7.50	9.50	9.50	9.50
H1 [mm]	64.83	64.83	80.10	95.57	113.49	138.64
H2 [mm]	27.45	27.45	35.08	41.57	50.53	63.11
H3 [mm]	8.00	8.00	8.00	10.00	10.00	10.00
H4 [mm]	8.00	8.00	8.00	10.00	10.00	10.00
H5 [mm]	32.95	37.0	49.0	59.1	74.5	93.1
L3 [mm]	83.00	82.00	104.00	125.00	144.50	166.50
R2 [mm]	0.75	0.75	1.00	1.50	1.50	2.00
R3 [mm]	35.00	43.00	49.00	65.00	65.00	70.00
R4 [mm]	12.00	12.00	12.00	15.00	15.00	15.00
S1 [mm]	31.00	36.00	46.00	55.00	63.25	72.75
E2 [mm] minimum thread engagement	13.00	16.00	19.00	24.00	29.00	34.00

**DETAN D Tension Rod System**

Dimensions of couplers with hanger

**Annex B7**

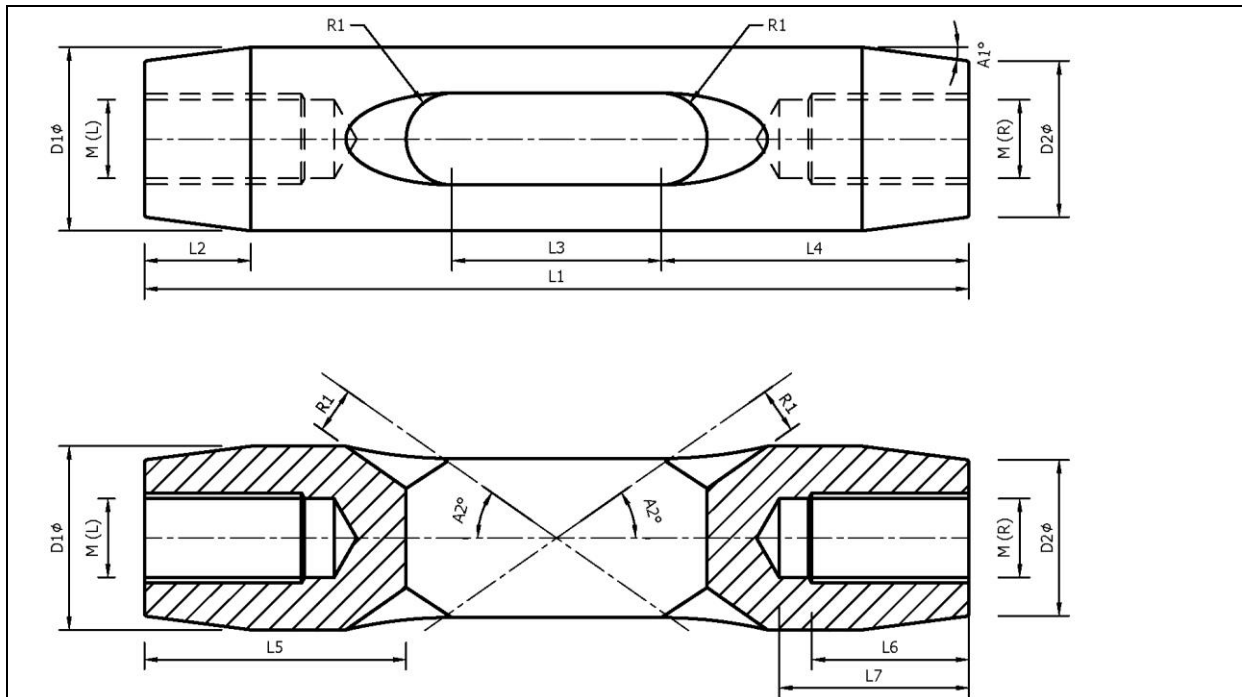

SIZE	M8	M10	M12	M16	M20	M24	M30	M36	M42
A1°	7.36	7.70	7.37	7.82	8.38	7.44	7.90	7.78	7.66
A2°	35.00	35.00	35.00	35.00	35.00	35.00	35.00	35.00	35.00
L1 [mm]	90.00	110.00	126.00	155.00	180.00	210.00	262.00	320.00	380.00
L2 [mm]	16.04	20.00	16.29	17.22	22.40	30.63	21.03	27.59	33.47
L3 [mm]	20.00	28.00	32.00	36.00	44.00	52.00	60.00	75.00	95.00
L4 [mm]	35.00	41.00	47.00	59.50	68.00	79.00	101.00	122.50	142.50
L5 [mm]	30.00	35.00	40.00	50.50	57.00	66.00	84.50	103.00	120.00
L6 [mm]	16.00	20.00	24.00	31.00	36.00	45.00	55.00	72.00	84.00
L7 [mm]	20.38	25.25	30.13	38.00	44.75	55.50	67.25	86.00	98.00
D1 [mm]	20.00	25.00	28.00	38.00	48.00	58.00	70.00	82.00	96.00
D2 [mm]	15.85	19.95	23.78	33.27	41.40	50.00	62.16	74.46	87.00
R1 [mm]	5.00	6.00	7.00	9.00	11.00	13.00	16.50	19.50	22.50
R2 [mm]	0.50	0.50	0.50	0.75	0.75	1.00	1.00	1.50	2.00

**DETAN D Tension Rod System**

Dimensions of cross couplers

**Annex B8**



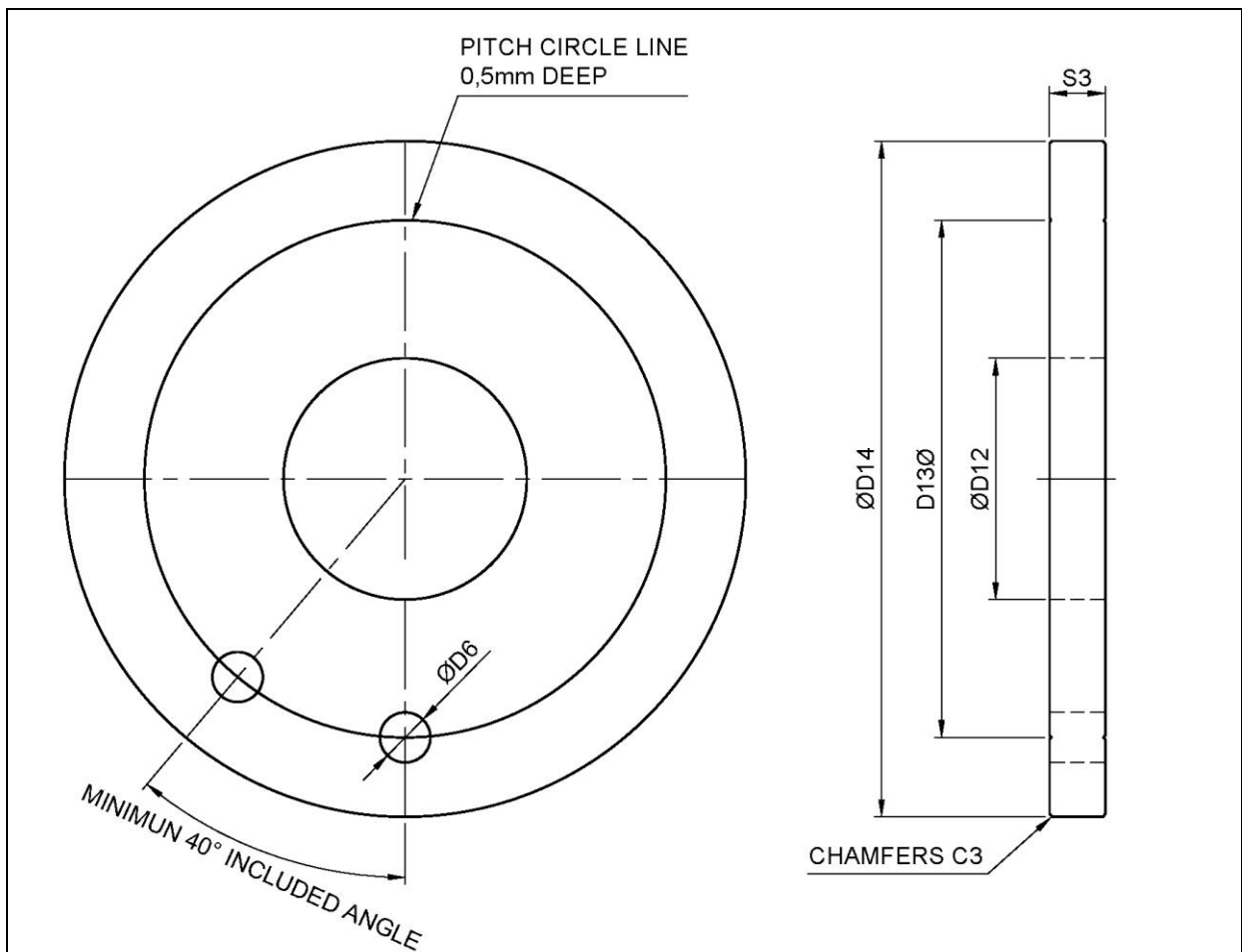

System size	M8	M10	M12	M16	M20	M24	M30	M36	M42
C3 [mm]	0.50	0.50	0.50	0.75	0.75	1.00	1.50	1.50	2.00
D6 [mm]	7.50	9.50	11.50	14.50	18.50	21.50	26.50	30.50	35.50
D12 [mm]	37.00	46.00	56.00	70.00	94.00	106.00	132.00	156.00	182.00
D13 [mm]	76.00	93.00	112.00	150.00	184.00	212.00	269.00	318.00	367.00
D14 [mm]	100.00	123.00	148.00	196.00	242.00	282.00	355.00	425.50	493.50
S3 [mm]	8.00	10.00	12.00	15.00	20.00	20.00	30.00	30.00	35.00

**DETAN D Tension Rod System**

Dimensions of anchor discs

**Annex B9**

Line no. [-]	Component [-]	System sizes		Material *) [number]	Yield strength [N/mm <sup>2</sup> ]	Ultimate strength [N/mm <sup>2</sup> ]
		from	to			
1	Fork head / lock nut	M8	M12	1.4462	355	510
2		M16	M42	1.4470	300	500
3	Pin / cap	M8	M12	1.4401 1.4404	250	580
4		M16	M42	1.4362 1.4462 1.4571	460	580
5	Tension rod	M8	M42	1.4401 1.4404 1.4062 1.4162 1.4362 1.4462 1.4571	460	650
6	Anchor disc	M8	M42	1.4401 1.4404 1.4362 1.4462 1.4571	445	640
7	Coupler / cross cou- pler	M8	M12	1.4401 1.4404	355	510
8		M16	M24	1.4362	250	510
9		M30	M42	1.4462 1.4571	250	400
10	Gusset plate	M8	M16	1.4401 1.4404	355	470
11		M20	M42	1.4362 1.4462 1.4571	345	470

\*) for details: see control plan

### **Corrosion protection**

Regarding corrosion protection, CRF (corrosion resistance factor) and CRC (corrosion resistance class) the information given in EN 1993-1-4:2006 + A1:2015 apply.

### **DETAN D Tension Rod System**

Material properties of stainless and stainless steel cast components

**Annex B10**

Line no. [-]	System size [-]	Design tension resistance of the tension rod system $F_{t,Rd}$ [kN]
1	M8	17.1
2	M10	27.1
3	M12	39.4
4	M16	73.3
5	M20	114.6
6	M24	165.0
7	M30	262.4
8	M36	382.2
9	M42	524.6

**DETAN D Tension Rod System**

Tension resistance of the tension rod system

**Annex B11**