

# CARES Technical Approval Report TA2 5017



Issue 5

Electronic Copy [www.carescertification.com](http://www.carescertification.com)

**Leviat**  
A CRH COMPANY

## **Ancon Eazistrip Reinforcement Continuity System**

Assessment of the  
Ancon Eazistrip  
Reinforcement Continuity  
System Product  
and Quality System  
for Production



# Product

## Ancon Eazistrip Reinforcement Continuity System

### Product approval held by:

Leviat  
President Way, President Park  
Sheffield S4 7UR  
Tel: +44 (0) 114 275 5224  
Fax: +44 (0) 114 276 8543  
Email: info.ancon.uk@leviat.com  
Web: Ancon.co.uk | Leviat.com

## 1 Product Summary

Ancon Eazistrip is designed to provide reinforcement continuity across wall to floor and wall to wall joints in structures. Ancon Eazistrip consists of selected reinforcement, pre-bent and housed in a purpose designed casing manufactured from galvanised steel, which has a dimpled surface to provide an effective key with the concrete.

The Ancon Eazistrip unit is fixed to a shutter and cast into the front face of the wall. After the formwork is struck, the case lid is removed to reveal the connection legs (or starter bars) lying inside the casing. These legs are bent out by the contractor, ready for lapping onto the main reinforcement of the next concrete pour.

The casing remains embedded in the wall, providing a rebate and key for the subsequent pour of the adjoining member.

### 1.1 Scope of Application

This approval covers the use of the Ancon Eazistrip reinforcement continuity system in reinforced concrete structures designed in accordance with BS EN 1992-1-1:2004 (EC2) and BS 8110-1:1997 which are subject to static loading in non-cryogenic environments. Design references in this approval all relate to BS EN 1992-1-1:2004.

### 1.2 Design Considerations

Re-bending of reinforcement is a matter of product suitability and workmanship. Design for shear along the axis of a joint is not covered by either standard and some guidance on it is given in Section 3.2.

Designs of wall-to-floor joints for bending and vertical shear, including the anchorages of the continuity bars in the wall, can be made according to EC2 (see section 6.3.1). The expressions given there were used, with safety factors removed, in the assessment of the results of tests (Section 6.3).

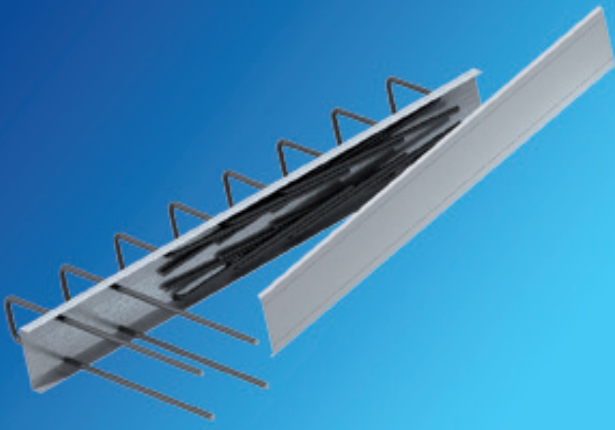

### 1.3 Conclusion

It is the opinion of CARES that the Ancon Eazistrip is satisfactory for use within the limits stated in paragraph 1.1 when installed and used in accordance with the manufacturer's instructions and the requirements of this certificate.

L. Brankley  
Chief Executive Officer  
April 2023

Electronic Copy www.carescertification.com



## 2 Technical Specification

### 2.1 General

The Ancon Eazistrip reinforcement continuity system is a quick and easy way of maintaining continuity of reinforcement at construction joints in concrete. The system is manufactured by Leviat in a CARES quality assured manufacturing unit.

The system consists of a galvanised steel casing with a dimpled surface to provide an effective shear key with the concrete. Pre-bent bars are housed within the casing and are enclosed by a protective cover; each end of the unit is sealed with a polystyrene block in order to prevent the ingress of concrete.

The type of reinforcement used is selected by Leviat to provide a suitable degree of ductility, ensuring that it complies with the tensile requirements of BS4449:2005, Grades B500B and B500C after pre-fabrication and re-bending on site. The material is CARES approved, assuring consistent compliance with the product standard. Material processing is CARES approved to ensure full traceability from steel mill to customer.

Ancon Eazistrip is available in bar sizes 10, 12 and 16mm. Where bars are to be re-bent, the original bends are to the radii noted in Table 1 and are greater than the minimum required by EC2.

All other bends meet the requirements of EC2, Table 8.1N and BS 8666:2005.

Bar Diameter	Bend Form Radius	Mandrel Diameter
10mm	30mm	60mm (6Ø)
12mm	36mm	72mm (6Ø)
16mm	50mm	100mm (6.25Ø)

**Table 1**

Ancon Eazistrip is available in a wide range of customer specified shapes and options (refer to Figure 1) and can also be supplied radiused to suit circular structural elements.

The shape used in the wall/floor joints tested for CARES was type U. The suitability of other types should be assessed by the designer.

### Shape Types

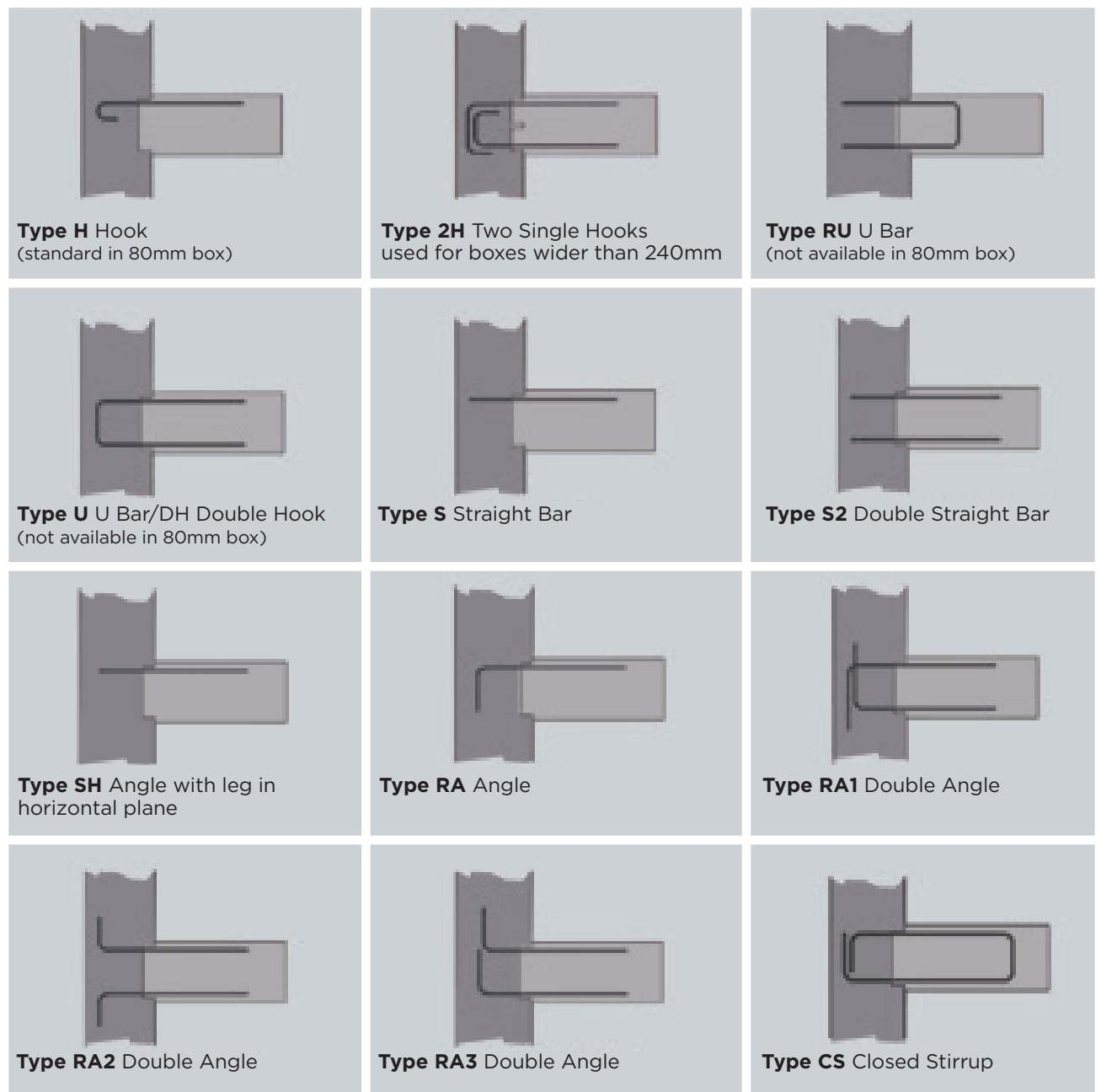

Figure 1 - Shapes

Electronic Copy www.carescertification.com



## 3 Product Performance and Characteristics

### 3.1 Reinforcement Tensile Properties

Mechanical tests on the reinforcement showed that the material, after bending and straightening, complied with the tensile requirements of BS4449 Grades B500B and B500C, exhibiting values for total elongation at maximum load ( $A_{gt}$ ) of greater than 5% and 7.5% respectively.

### 3.2 Strength of Joints

#### Wall to floor joints

Structural tests showed that the flexural strength and shear strength of construction joints formed with the Ancon Eazistrip reinforcement continuity system are no less than those of equivalent traditionally formed construction joints.

#### Wall to wall joints

The resistance of a joint to shear along its axis depends on contact between the dimples of the casing and the concrete either side of it and on the ability of the continuity reinforcement (or external actions) to resist the forces normal to the joint engendered by shear transfer. The results of a limited series of tests, with purely shear loading, are consistent with the design expression

$$V_{Rd} = 0.7 A_s f_{yd} < 0.44 (f_{ck})^{0.5} A_c$$

where

$V_{Rd}$  = design shear resistance

$A_s$  = area of continuity reinforcement normal to the joint

$f_{yd}$  = design yield stress of continuity reinforcement  
[435MPa] for grade 500 bars

$f_{ck}$  = characteristic cylinder strength of concrete

$A_c$  = area of concrete in contact with rear face of casing.

The tests were made with 190mm wide casing in joints between parallel sections of 240mm wide walls, with contact between the first and second pours of concrete prevented by 25mm deep slots formed between them within the second pour. The upper limit in the equation is simply the value corresponding to the largest ratio of the reinforcement used in the tests.

### 3.3 Serviceability Limit States

#### 3.3.1 Deflection

The deflection of elements is not a function of this product insofar as the joints formed using Ancon Eazistrip were able to ensure full structural continuity during testing and did not exhibit any significant additional rotation relative to the joint.

#### 3.3.2 Cracking

In the tests conducted there was very little vertical cracking at the inner faces of the walls and the rotation of the slab relative to the wall occurred by an opening between the concrete and the back face of the Ancon Eazistrip casing. This ran along the upper horizontal leg of the casing and resulted in an opening between the inner face of the wall and the top of the slab.

#### 3.3.3 Calculation of Crack Widths

Crack widths at joints are not generally assessed in EC2 designs but the following equation can be used to estimate the width of the opening referred to above at the level of the top bars:

$$\omega = \frac{\sigma_s^2 \phi_s}{4E_s \tau}$$

where

$\sigma_s$  = the steel stress in the crack

$\phi_s$  = the bar diameter

$\tau$  = the average bond stress

=  $0.5 f_{ck}^{2/3}$  for short-term/instantaneous loading

=  $0.4 f_{ck}^{2/3}$  for long-term/repeated loading

$\omega$  = the crack width at the level of the centre of the steel

$E_s$  = the elastic modulus of the steel



## 4 Installation

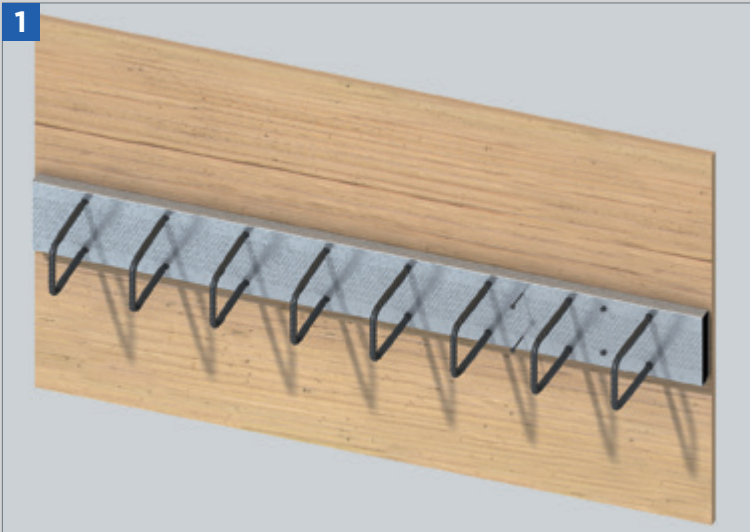

Nail the Ancon Eazistrip through the casing to the formwork or alternatively securely tie the projecting anchorage reinforcing bars back to the main reinforcement. In both cases the Ancon Eazistrip boxes should be securely fixed to avoid displacement during concreting. The casing should be tight against the formwork. Pour concrete.

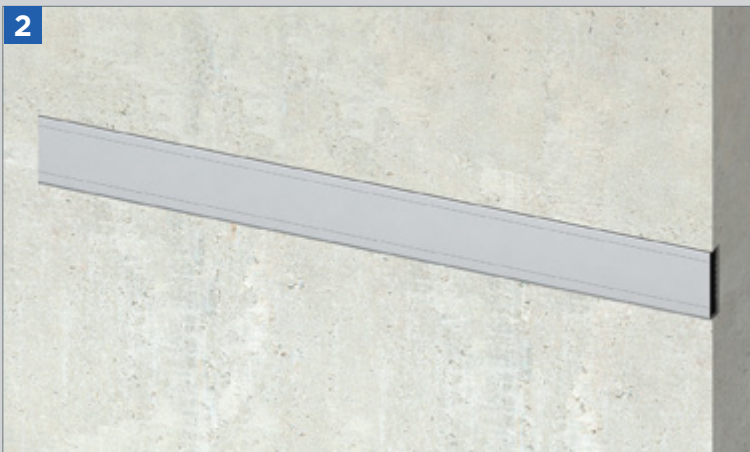

Strike the formwork to reveal the cover.



Remove the cover to expose the pre-bent bars.



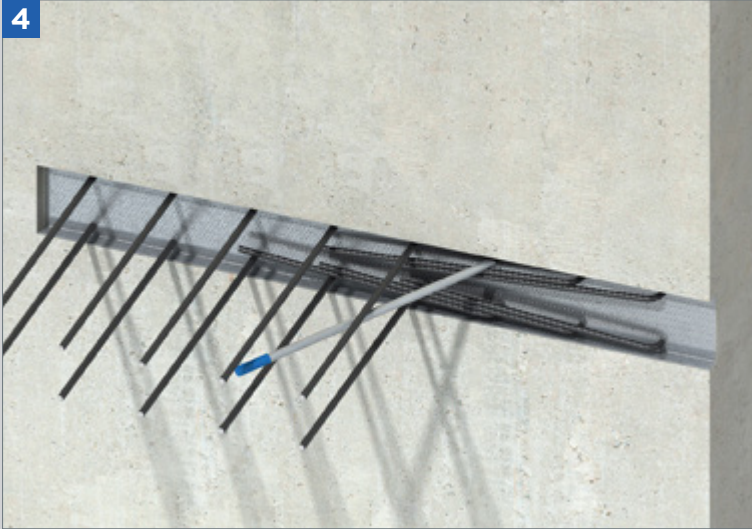

**Straighten the bars using the appropriate sized Ancon Eazistrip re-bending tool for the size of bar. The bars should be straightened only once. To avoid damage to adjacent concrete, it is prudent to allow a concrete curing period of seven days. See “Straightening of Bars” for more information.**



**Once the bars are straightened and aligned they are ready for lapping with the concrete element reinforcement, provided by others.**

## 4.1 Straightening of Bars

The bars in the Ancon Eazistrip box must be straightened using the appropriate sized Eazistrip rebending tool (Figure 2). This is a steel tube designed to fit over the bar, the internal diameter being slightly larger than the maximum dimension over the ribs of the bar. One end of the tube has a section cut away; this provides support to the outside of the bend during straightening of the bar and limits the point contact of the tube on the bar. Use of the tool allows the re-bending process to be carried out in a smooth continuous action (avoiding jerky action), the tube being moved along the bar and around the bend as it is straightened. Scaffold tubes or similar must not be used to straighten bar. To enable the re-bending tool to be fitted on to the bar, the bar should be pulled the minimum distance from the Ancon Eazistrip steel casing to enable this.

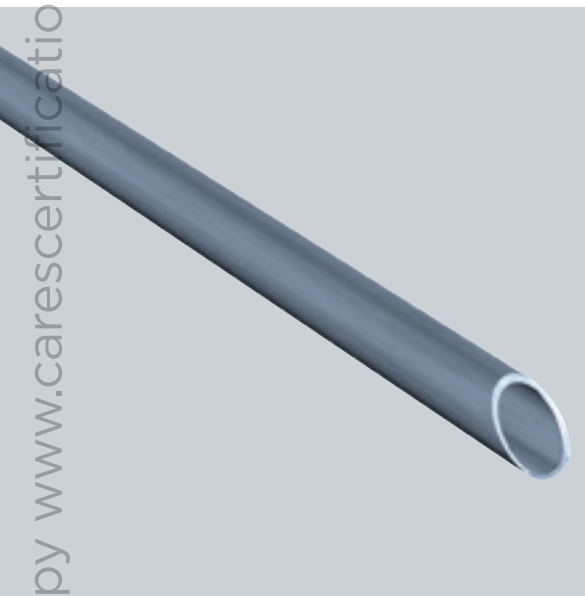

**Figure 2**

The re-bending tool should then be slid along the bar to the start of the bend radius. The bar straightening process should be smooth and progressive with the tube allowed to move along the bend towards the metal casing as it is straightened. The tool should contact the Ancon Eazistrip steel casing at the completion of the straightening process.

The tube is then removed and the straightened bar checked for alignment and cover with the adjoining reinforcement. The Ancon Eazistrip reinforcing bars should not be straightened when the temperature of the steel is below 5°C. Where straightening is necessary below 5°C, indirect warming of the steel to a temperature not exceeding 100°C is permitted. Bending the bar in excess of the recommendations will also result in work hardening of the rebar and should therefore be avoided.

## 4.2 Storage

Ancon Eazistrip should be suitably stored in order to protect it from mechanical damage and corrosion.

### 4.3 On-Site Cutting

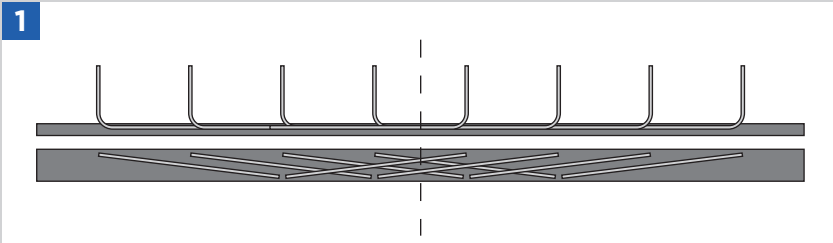

Identify the location of the intended cut.

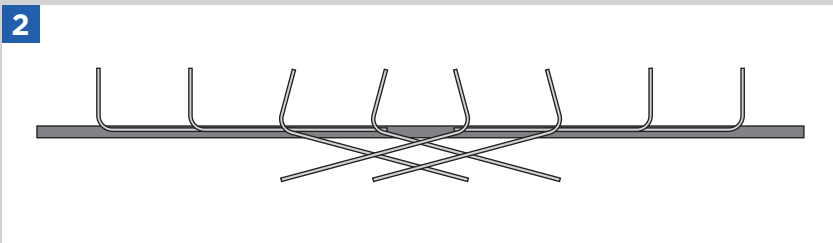

Slide the protective cover from the box and remove the bars which pass over the cut location.

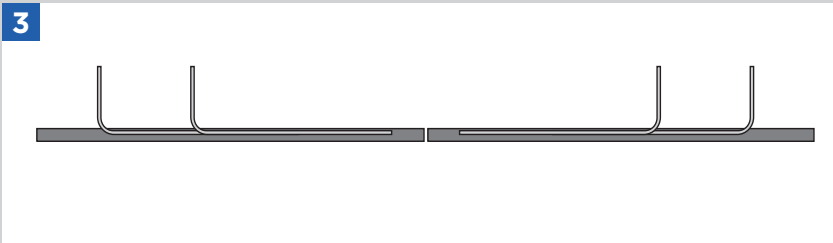

Cut through the steel casing using a disc cutter.

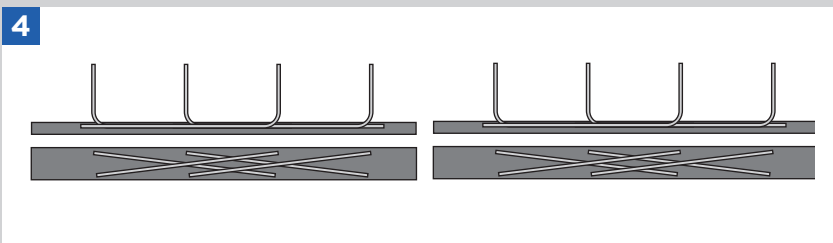

Replace the bars to face the opposite direction to their original position. Cut the cover to the same lengths as the steel casing and replace to protect the bars. The ends of the boxes must be sealed, using polystyrene blocks, to prevent the ingress of concrete.

**Note:** Protective gloves should be worn when removing covers, straightening bars, cutting boxes and during general handling of Ancon Eazistrip.



Electronic Copy www.carescertification.com

## 5 Safety Considerations

Normal practice is to palletise Ancon Eazistrip units for mechanical handling. Attention should be given to recognised manual handling procedures and regulations. Individual casing units weighing up to 25kg may be handled manually provided due care is taken; the weight of each unit is normally identified on each casing label.

Heavier units may require mechanical handling equipment. Protective gloves should be worn when removing covers, straightening bars, cutting boxes and during general handling.

Heat should not be applied to the Ancon Eazistrip casing as it is galvanised and may produce dangerous fumes.

## 6 Product Testing and Evaluation

### 6.1 General

The Ancon Eazistrip reinforcement continuity system was evaluated in two stages:

- 6.1.1** The reinforcement was subject to independent mechanical testing to establish its suitability for bending during the prefabrication process and rebending through 90 degrees during the straightening process on site and subsequent compliance with the tensile requirements of BS4449.
- 6.1.2** Ancon Eazistrip reinforcement continuity system samples were subject to a programme of full scale structural testing in concrete to evaluate the performance of the construction joints under combinations of high shear and high flexural loading. Construction joints were also subject to tests of longitudinal shear.

### 6.2 Mechanical Testing

The selected reinforcement was tested to determine the appropriate bend radii.

Reinforcement was subject to the CARES bendability test, which consisted of bending the reinforcement through 90 degrees over a steel former, straightening and examination of the inside of the bend for signs of fracture. The test was conducted twice on each sample.

Reinforcement was also subject to the CARES tensile test regime, which consisted of bending the reinforcement through 90 degrees over a steel former and straightening with the Ancon Eazistrip tool prior to tensile testing to measure the Ultimate Tensile Strength, Yield Strength and Elongation at Maximum Load ( $A_{gt}$ ). The selected reinforcement were found to comply with the tensile requirements of BS4449:2005 Grades B500B and B500C. (Clause 7.2.3, Table 4).

### 6.3 Full Scale Structural Testing

Full scale structural tests have been conducted on construction joints formed using the Ancon Eazistrip continuity system to determine flexural strengths, vertical shear strengths and openings at joints for wall/floor joints and the longitudinal shear strengths for wall/wall joints.

The largest bar diameter 16mm in grade B500C was chosen for the majority of the wall/floor slab tests as being the largest bar size used in the Ancon Eazistrip continuity system and that which imposes the greatest stresses on the surrounding concrete and the most severe demands on the reinforcement in relation to bending and straightening.

The tests showed that flexural and shear strengths of wall/floor slab joints were to the safe side of values calculated by EC2 with safety factors removed, and that joint openings could be safely calculated by the equation in section 3.3.3. The longitudinal shear strengths were on the safe side of the equation in section 3.2 with safety factors removed.

The test arrangements are shown in Figs 3, 4 & 5.

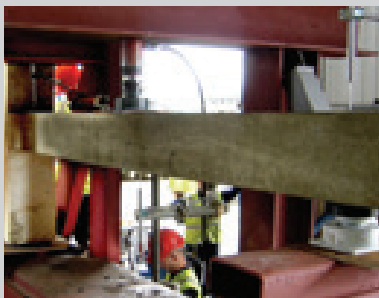

General wall/slab test arrangement showing jack, with load cells near the centre of slab and at the support remote from the wall.

**Figure 3**



Post load test, showing ultimate shear failure mode; a continuous polystyrene strip was cast into the wall beneath the Ancon Eazistrip joint to simulate poor compaction of the concrete. The wall/slab connection remains essentially intact.

**Figure 4**



Longitudinal shear test arrangement with Ancon Eazistrip cast into one side of the joint. The load was applied by jack through the test frame.

**Figure 5**



## 6.3.1 Assessment of Anchorage

### 6.3.1.1 General

To avoid damage to reinforcement the minimum mandrel diameter for hooks and bends given in EC2 is  $\varnothing_{m,min} = 4\varnothing$  where  $\varnothing$  is the bar diameter. This value is used in standard Ancon Eazistrip units for all bends except those to be straightened on site. A mandrel diameter of  $6\varnothing$  is used where the bars are to be straightened.

In general the anchorage capacity of bars with hooks or bends is determined by either the maximum bearing stress between the bars and the concrete in the bends or by the average bond stress along the anchorage length.

### 6.3.1.2 Anchorage capacity limited by bearing stresses

Provided that mandrel diameters  $\varnothing_m$  for hooks and bends are at least  $\varnothing_{m,min}$ , the bearing stresses need not be checked if either (1) the anchorage length needed for bond does not require a length of more than  $5\varnothing$  past the end of the bend or (2) the bar is not positioned at an edge (plane of bend close to concrete face) and there is a cross bar with a diameter  $\geq \varnothing$  inside the bend - see Fig 6.

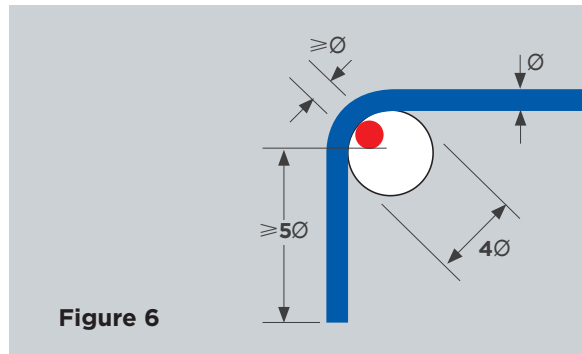

Figure 6

Otherwise the minimum mandrel diameter should be increased to

$$\varnothing_{m,min} = F_{bt} [(1/a_b) + 1/(2\varnothing)] / f_{cd}$$

where  $F_{bt}$  is the design ultimate force in a bar at the start of a bend

$a_b$  is half the centre to centre spacing of the bent bars or, for an edge bar, the side cover plus  $0.5\varnothing$  if this is less.

$f_{cd} = \alpha_{cc} f_{ck} / \gamma_c = 0.67 f_{ck}$  but not greater than the value for  $f_{ck} = 55$  MPa, i.e. 36.7 MPa.

$\alpha_{cc} = 1.0$  according to the UK national annex

$\varnothing$  is the bar diameter

If  $\varnothing_{m,min}$  cannot be increased to the value required by the above equation  $F_{bt}$  is limited to

$$F_{bt,R} = \varnothing \varnothing_m f_{cd} / [(\varnothing/a_b) + 0.5]$$

For a given loading,  $F_{bt}$  can be calculated assuming (1) the force in a bar at the back of the Ancon Eazistrip casing is equal to  $F_{sd}$ , the force at the face of the wall, and (2) the bond stress is constant along the design anchorage length  $l_{bd}$  whence (see Fig 7)

$$F_{bt,E} = F_{sd,E} (1 - l_a / l_{bd})$$

### 6.3.1.3 Anchorage capacity as limited by bond

The anchorage length required beyond the section where a bar passes through the Ancon Eazistrip casing is normally

$$l_{bd} = \alpha_1 \alpha_2 (\sigma_{sd} / f_{bd})$$

where  $\alpha_1 = 1.0$  for straight bars or  $0.7$  for bars with bends or hooks and with minimum side cover of at least  $3\varnothing$  and minimum clear spacing of at least  $6\varnothing$

$$\alpha_2 = 1.0.15(c_s - 3\varnothing) / \varnothing \geq 0.7$$

where  $c_s$  is the side cover or half the clear bar spacing

$\sigma_{sd}$  = design stress in bars at the start of the anchorage, which can be taken as equal to the stress at the inner face of the wall

$$f_{bd} = \eta_1 \eta_2 \times 0.315 f_{ck}^{2/3}$$

$\eta_1 = 1.0$  for bars more than 300mm below the top of the fresh concrete (in the wall) during casting, or  $0.7$  for bars within 300mm from the top during casting and for bars in slip-formed concrete

$\eta_2 = 1.0$  for  $\varnothing \leq 32\text{mm}$ .

The length  $l_{bd}$  is measured along the centre lines of the bars.

Figure 7 on page 15 shows typical anchorages. In the second case drawn, the length  $l$  available for  $l_{bd}$  is limited in view of uncertainty about bond stresses beyond the second bend.



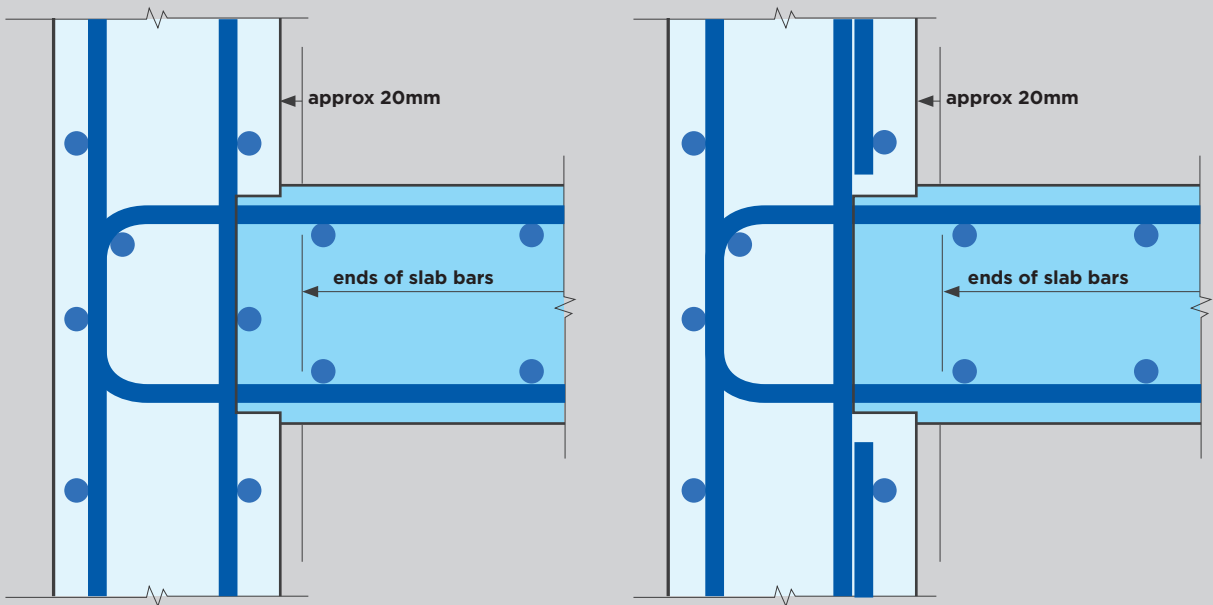
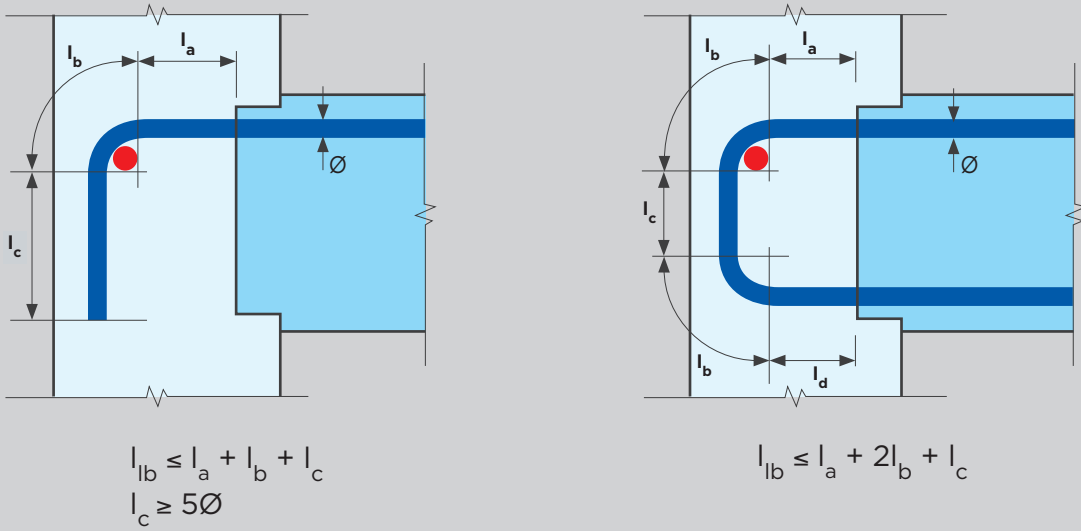

Continuity of bars along with other reinforcement defining the starting points for laps with slab bars showing what to do if the casing interrupts the vertical bars at the inner face of the wall.

Figure 7



## 7 Quality Assurance

The Ancon Eazistrip continuity systems are produced under an ISO9001 quality management system certified by CARES.

The quality management system scheme monitors the production of the continuity system and ensures that materials remain within the limits of this technical approval.

## 8 Building Regulations

### 8.1 The Building Regulations (England and Wales)

#### Structure, Approved Document A

Ancon Eazistrip continuity system, when used in EC2 based designs using the data contained within this technical approval, satisfy the relevant requirements of The Building Regulations (England and Wales), Approved Document A.

#### Materials and Workmanship, Approved Document

This technical approval gives assurance that the Ancon Eazistrip continuity system comply with the material requirements of EC2.

### 8.2 The Building Regulations (Northern Ireland)

#### Materials and Workmanship

This technical approval gives assurance that Ancon Eazistrip continuity system comply with the material requirements of EC2 by virtue of regulation 23, *Deemed to satisfy provisions regarding the fitness of materials and workmanship.*

### 8.3 The Building Standards (Scotland)

#### Fitness of Materials

This technical approval gives assurance that Ancon Eazistrip continuity system comply with the material requirements of EC2 by virtue of *Clause 0.8.*

#### Structure

Ancon Eazistrip continuity system, when used in EC2 based designs using the data contained within this technical approval, satisfy the requirements of *The Building Standards (Scotland) clause 1.*



## 9 References

- BS 4449: 2005: Steel for the reinforcement of concrete - Weldable reinforcing steel - Bar, coil and decoiled product - Specification.
- BS 8666: 2005: Scheduling, dimensioning, bending and cutting of steel reinforcement for concrete - Specification.
- BS8110: Part 1: 1997: (amended 2007) Structural Use of Concrete, Code of Practice for Design and Construction.
- BS EN ISO 9001: Quality management systems - Requirements.
- CARES Appendix TA2; Quality and Operations Schedule for the Technical Approval of Reinforcement Continuity Systems.
- Taylor Woodrow Technology Centre, Load testing of Ancon continuity reinforcement systems in concrete samples, Technical Report No N950/07.
- Prof. P. E. Regan, Evaluation of the results of tests of the Ancon Eazistrip Continuity System, Oct 2007.

## 10 Conditions

1. The quality of the materials and method of manufacture have been examined by CARES and found to be satisfactory. This technical approval will remain valid provided that:
  - a) The product design and specification are unchanged.
  - b) The materials, method of manufacture and location are unchanged.
  - c) The manufacturer complies with CARES regulations for Technical Approvals.
  - d) The manufacturer holds a valid CARES Certificate of Product Assessment.
  - e) The product is installed and used as described in this report.
2. CARES make no representation as to the presence or absence of patent rights subsisting in the product and/or the legal right of Leviat to market the product.
3. Any references to standards, codes or legislation are those which are in force at the date of this certificate.
4. Any recommendations relating to the safe use of this product are the minimum standards required when the product is used. These requirements do not purport to satisfy the requirements of the Health and Safety at Work etc Act 1974 or any other relevant safety legislation.
5. CARES does not accept any responsibility for any loss or injury arising as a direct or indirect result of the use of this product.
6. This Technical Approval Report should be read in conjunction with CARES Certificate of Product Assessment No 5017. Confirmation that this technical approval is current can be obtained from CARES.





Electronic Copy www.carescertification.com

## CARES

Pembroke House  
21 Pembroke Road  
Sevenoaks  
Kent TN13 1XR

Phone: +44(0)1732 450000  
E-mail: [general@carescertification.com](mailto:general@carescertification.com)  
[www.carescertification.com](http://www.carescertification.com)



**Independent Product Assessments  
for the Construction Industry**

Copyright CARES ©