

UK &  
Ireland  
Edition



Compliant with  
**BS 8597: 2015**

# Ancon<sup>®</sup>

## Reinforcing Bar Couplers

for the Construction Industry



# **We are one team.** **We are Leviat.**

Leviat is the new name of CRH's construction accessories companies worldwide.

Under the Leviat brand, we have united the expertise, skills and resources of Ancon and its sister companies to create a world leader in fixing, connecting and anchoring technology.

The products you know and trust will remain an integral part of Leviat's comprehensive brand and product portfolio. As Leviat, we can offer you an extended range of specialist products and services, greater technical expertise, a larger and more agile supply chain and better, faster innovation.

By bringing together CRH's construction accessories family as one global organisation, we are better equipped to meet the needs of our customers, and the demands of construction projects, of any scale, anywhere in the world.

**This is an exciting change. Join us on our journey.**

**Read more about Leviat at [Leviat.com](https://www.leviat.com)**



Our product brands include:

**Ancon**

  
**HALFEN**

**HELIFIX** 

 **ISEDIO**

**PLAKA**



**60**

locations

sales in  
**30+**  
countries

**3000**

people worldwide

Imagine. Model. Make.

[Leviat.com](http://Leviat.com)

# Reinforcing Bar Couplers

## Simplify the design and construction of concrete

Lapped joints are not always an appropriate means of connecting reinforcing bars. The use of laps can be time consuming in terms of design and installation and can lead to greater congestion within the concrete because of the increased amount of rebar used.

Ancon couplers can simplify the design and construction of reinforced concrete and reduce the amount of reinforcement required.

Lapped joints are dependent upon the concrete for load transfer. For this reason any degradation in the integrity of

the concrete could significantly affect the performance of the joint. The strength of a mechanical splice is independent of the concrete in which it is located and will retain its strength despite loss of cover as a result of impact damage or seismic event.

The range of reinforcing bar couplers is the most comprehensive available and includes tapered threaded, parallel threaded, mechanically bolted and grouted couplers. Couplers for stainless steel and cryogenic-grade rebars complete the range.



## Contents

<a href="#">Coupler Selection</a>	4-5	<a href="#">Bartec Plus Weldable Anchors</a>	20
<a href="#">Tapered Thread Standard Series</a>	6-7	<a href="#">Bartec Plus Headed Anchors</a>	21
<a href="#">Tapered Thread Positional Series</a>	8-9	<a href="#">MBT ET Series</a>	22
<a href="#">Tapered Thread Transition Series</a>	10	<a href="#">MBT Transition Series</a>	23
<a href="#">Tapered Thread Weldable Couplers</a>	11	<a href="#">Electric Wrench</a>	23
<a href="#">Tapered Thread Headed Anchors</a>	12	<a href="#">MBT Continuity C Series</a>	24
<a href="#">Accessories</a>	12	<a href="#">Repair and Remedial Work</a>	25
<a href="#">BT Stainless Steel Couplers</a>	13	<a href="#">MBT Headed Anchors</a>	26
<a href="#">Bartec Plus Types A, B &amp; C</a>	14-16	<a href="#">HM Grout Sleeve Couplers</a>	27
<a href="#">Bartec Plus Transition Couplers</a>	17-19	<a href="#">Other Ancon Products</a>	27

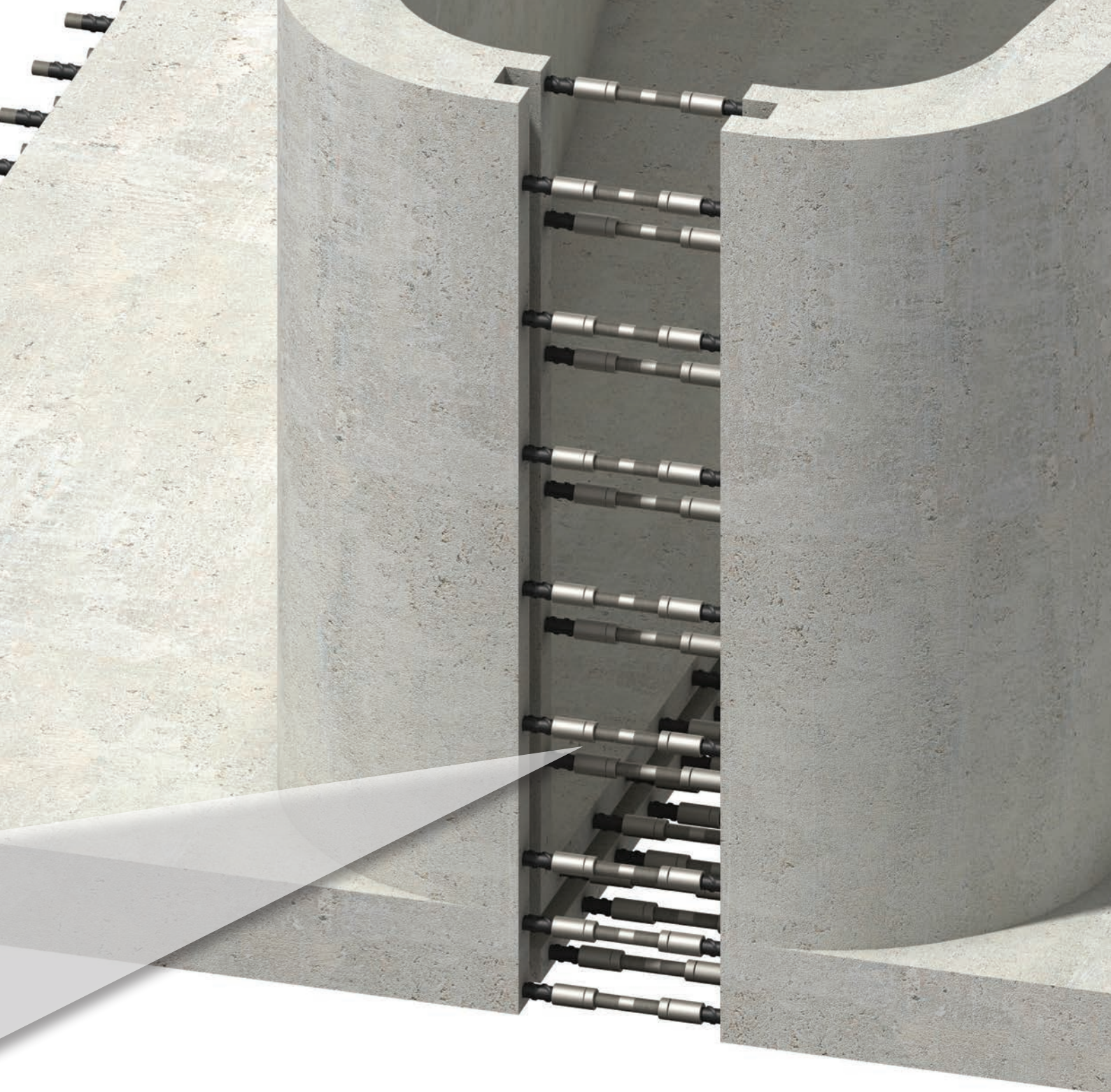

Comprehensive range



Simplify design and construction



Reduce amount of reinforcement required



Dedicated sales support



Available through major rebar stockists and approved distributors



ISO 9001, ISO 14001, OHSAS 18001



Eurocode 2 compliant



BS 8597: 2015 compliant



Technical approval TA1-B 5015 for Tapered Thread Couplers



Technical approval TA1-A 5050 for Bartec Plus Couplers



Technical approval TA1-A & TA1-B 5083 for MBT Couplers

Refer to the approval reports for coupler sizes and types covered.

# Reinforcing Bar Couplers

For many years the use of mechanical couplers to join reinforcing bars has been regarded as a means of reducing the use of long bars. Engineers and contractors now recognise the benefits of using couplers to accelerate the speed of construction, increase productivity and simplify design details.

## Sales Support

Our 'Products for Structural Concrete' Division provides assistance for clients who require products which are used in concrete construction. These include, but are not restricted to, reinforcing bar couplers, reinforcement continuity systems, punching shear reinforcement and shear load connectors. A dedicated team is available to offer technical advice, pricing information and guidance on the selection of the most appropriate product for a specific application. Enquiries from overseas are also dealt with by the PSC team. To contact the team please email [reinforcement.uk@leviat.com](mailto:reinforcement.uk@leviat.com) or call +44 (0) 114 275 5224.

## UK and Ireland Edition

This literature is written for the UK and Irish market. It does not feature the full Ancon range of couplers or national approvals. For other products and bar sizes, please contact Leviat.

## Coupler Selection

The Ancon range of reinforcing bar couplers require different fixing methods. This, together with the quantity to be fixed and the location, will determine which is the most appropriate coupler for a particular situation.

## Characteristic Strengths of High Yield Reinforcing Bar

Diameter (mm)	Area (mm <sup>2</sup> )	Grade B500 Fy (kN)	Grade B500B UTL (kN)	Grade B500C UTL (kN)
12	113.1	56.5	61.1	65.0
16	201.1	100.5	108.6	115.6
20	314.2	157.1	169.6	180.6
25	490.9	245.4	265.1	282.3
32	804.2	402.1	434.3	462.4
40	1,256.6	628.3	678.6	722.6



### Tapered Thread (pages 6-12)

The Tapered Thread coupler is designed to suit the majority of applications which require the joining of reinforcing bars. The ends of the rebar are cut square and a tapered thread is cut onto the bar to suit the tapered thread coupler. The sleeve is tightened onto the threaded bar end using a calibrated torque wrench.

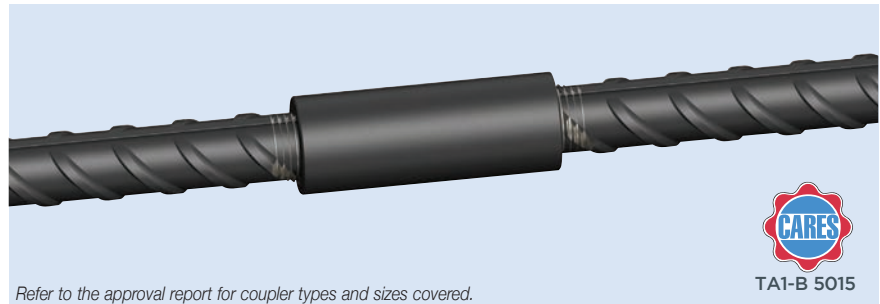

*Refer to the approval report for coupler types and sizes covered.*

### Bartec Plus (pages 14-21)

Bartec Plus couplers provide a full strength joint and are the smallest couplers in the Ancon range. They are particularly appropriate for applications where fatigue is an issue. The ends of the bars are cut square and marginally enlarged. A parallel thread is then rolled onto the ends to suit the threaded sleeve. The coupler is installed using a pipe or chain wrench. Calibrated torque wrenches are not required.

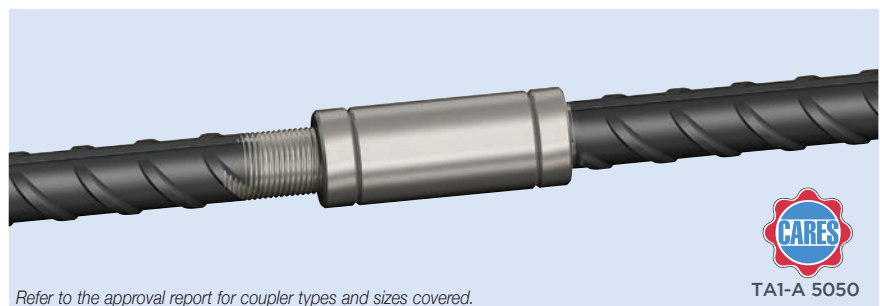

*Refer to the approval report for coupler types and sizes covered.*

### MBT (pages 22-26)

MBT couplers are suitable where it is not convenient to have the bar ends prepared for parallel thread or tapered thread couplers. The bars are supported within the coupler on two serrated saddles. Bars are locked in place by a series of special lockshear bolts, the heads of which shear off when the predetermined tightening torque is reached, providing a visual check of correct installation.

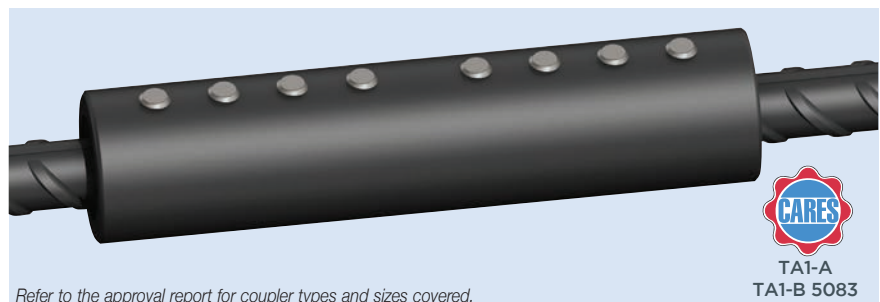

*Refer to the approval report for coupler types and sizes covered.*

### Stainless Steel Couplers (page 13)

### Grout Sleeve Couplers (page 27)

## Coupler Selection

Range Type	Tapered Thread					Bartec Plus					MBT			
	TTS Standard	TTP Positional	TTT Transition	TTW Weldable	TTH Anchor	Type A	Type B	Type C	Weldable	Anchor	ET Series Standard	MBT Transition	C Series Continuity	Headed Anchor
Bar Dia. (mm)	12-40	12-40	12-40	12-40	12-40	12-40	12-40	12-40	12-40	12-40	12-40	12-40	12-40	12-40
Bar End Prep	Threaded	Threaded	Threaded	Threaded	Threaded	Threaded	Threaded	Threaded	Threaded	Threaded	No	No	No	No
Bar Rotation	Yes	No	Yes	Yes	No	Yes	Limited	No	Yes	No	No	No	No	No
Assembly Tool	Torque Wrench					Pipe Wrench					Nut Runner or Socket Wrench			
Minimum Tensile Capacity	Full Strength up to 575N/mm <sup>2</sup>					Full Strength up to 575N/mm <sup>2</sup>					Full Strength up to 575N/mm <sup>2</sup>			
Approval	UK CARES TA1-B Approval 5015*					UK CARES TA1-A Approval 5050*					UK CARES TA1-A & TA1-B 5083			

\*Refer to the approval report for coupler types and sizes covered.

## Availability of Couplers

Bar Diameter (mm)	12	16	20	25	32	40
Tapered Thread Standard	✓	✓	✓	✓	✓	✓
Tapered Thread Positional	✓	✓	✓	✓	✓	✓
Tapered Thread Transition	✓	✓	✓	✓	✓	✓
Tapered Thread Weldable	✓	✓	✓	✓	✓	✓
Tapered Thread Anchor	✓	✓	✓	✓	✓	✓
BT-S Stainless Steel Standard	✗	✓	✓	✓	✓	✓
Bartec Plus Standard	✓	✓	✓	✓	✓	✓
Bartec Plus Transition	✓	✓	✓	✓	✓	✓
Bartec Plus Anchor	✓	✓	✓	✓	✓	✓
Bartec Plus Weldable	✓	✓	✓	✓	✓	✓
MBT ET	✓	✓	✓	✓	✓	✓
MBT Transition	✓	✓	✓	✓	✓	✓
MBT Continuity	✓	✓	✓	✓	✓	✓
MBT Anchor	✓	✓	✓	✓	✓	✓

## Application Guide

The following table provides a guide when selecting the most appropriate couplers for specific applications. Recommendations are based upon typical usage. Please contact Leviat for further assistance on the correct selection and specification of Ancon couplers.

Application	Tapered Thread	BT-S	Bartec Plus	MBT
Wall to slab connection	✓	✓	✓	✗
Wall to pre-cast beam connection	✓	✓	✓	✗
Column construction	✓	✓	✓	✓
Extension / repairs to existing structures	✗	✗	✗	✓
PC element to PC element connection	✓	✓	✓	✓
Closing of access openings	✓	✓	✓	✓
Rebar cage pre-fabrication	✓	✓	✓	✓
Hook bars to pile connection	✗	✗	✗	✓
Fatigue applications / highway structures	✗	✗	✓	✓
Bar end terminations	✓	✓	✓	✓

## Cryogenic Couplers

The Ancon CTT range of tapered-thread couplers has been designed for use where cryogenic-grade reinforcing bar is being used. Typical construction projects include liquefied natural gas (LNG) and liquefied petroleum gas (LPG) storage tanks to EN 14620-3. Contact us for full technical details or download the product brochure online.



# Reinforcing Bar Couplers

## Tapered Thread

The Ancon range of Tapered Thread couplers is designed to suit the majority of applications which call for the joining of reinforcing bars. Available to suit bar sizes 12mm to 40mm, the couplers are installed quickly and easily on site without the need for specially trained personnel or specialised, expensive machinery.

The compact design of each coupler ensures suitability for use in confined situations where space is restricted or where the loss of cover must be minimised. The couplers are normally supplied fitted to the end of threaded bar, requiring only the engagement and tightening of the adjoining bar on site. In order to ensure correct installation, we specify the use of a torque wrench.

The range of Tapered Thread couplers is available through major rebar suppliers. Please contact Leviat for further details.

## Standard Coupler

The Standard Tapered Thread coupler is suitable for connecting two bars of the same diameter, where one bar can be rotated. It comprises an internally threaded sleeve with two right hand threads which are tapered towards the middle of the coupler. The bar ends are square cut and a tapered thread is cut onto the bar. A nominal allowance of +25mm should be allowed per threaded bar end for square cutting the bar end.

The couplers are generally torqued onto the reinforcing bar in the bar threading shop, the internal threads protected by plastic end caps. The threaded ends of the continuation bar are protected by plastic thread protectors.

Engagement of the bar within the coupler is simplified by the tapered thread design which aids alignment. When the bar is fully engaged within the coupler, the continuation bar is tightened using a torque wrench.

The Ancon Standard Tapered Thread coupler is compliant with BS 8597: 2015 Steels for the Reinforcement of Concrete. Reinforcement Couplers. Requirements and Test Methods. They are designed to achieve failure loads in excess of 115% of the characteristic strength of grade 500 rebar.

### Standard Coupler Dimensions

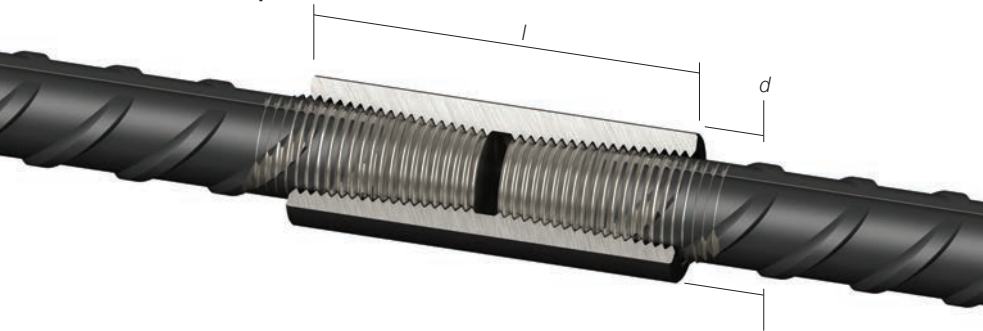

Bar Diameter (mm)		12	16	20	25	32	40
External Dia. (mm)	<i>d</i>	22	25	30	36	48	60
Coupler Length (mm)	<i>l</i>	58	70	74	90	112	138
Weight (kg)		0.13	0.17	0.25	0.43	0.99	1.90
Torque (Nm)		60	110	165	265	285	330
Part No.		TTS12	TTS16	TTS20	TTS25	TTS32	TTS40

### Testing and Approvals

The Standard range of Tapered Thread couplers has been tested and approved by UK CARES to show compliance with the requirements of BS EN 1992-1-1: 2004 (Eurocode 2), BS 8110 and UK CARES TA1-B.



Validate with the CARES Cloud App







### Installation Tapered Thread Standard Series



The coupler is normally supplied fixed to the reinforcing bar, ready to be installed and cast in concrete.

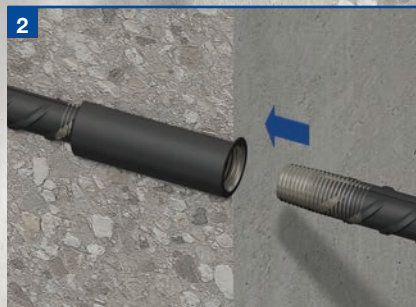

After casting the concrete and when ready to extend, remove the plastic end cap from the coupler. Position the continuation bar in the sleeve and rotate the bar into the coupler.



Continue to screw the bar into the coupler until tight.

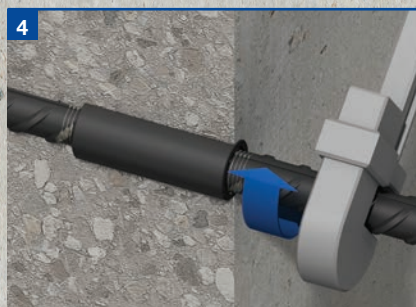

To ensure correct installation, tighten the joint to the specified torque using a calibrated torque wrench on the continuation bar. Tightening torques are shown in the table opposite.

# Reinforcing Bar Couplers

## Positional Coupler

The Ancon Tapered Thread Positional coupler is designed to be used in applications in which neither bar can be rotated. Having a degree of adjustability, the Positional coupler can also be used as a closer between two fixed bars.

The Positional coupler comprises three components, a male section, a female section and a locking nut. The male component has an internal tapered thread and an extended external parallel thread. The female component has a parallel thread and a tapered thread, both of which are internal. A locknut is used to secure the connection when the correct degree of adjustability has been achieved. All components, including the locknut must be tightened using a torque wrench.

Plastic thread protectors are used to prevent damage to the threaded bar ends and the internal threads of the couplers are protected by plastic end caps. A nominal allowance of +25mm should be allowed per threaded bar end for square cutting the bar end.

### Testing & Approvals

The Positional range of Tapered Thread couplers has been tested and approved by UK CARES to show compliance with the requirements of BS EN 1992-1-1: 2004 (Eurocode 2), BS 8110 and UK CARES TA1-B. This range is also compliant with BS 8597: 2015.

### Positional Coupler Dimensions

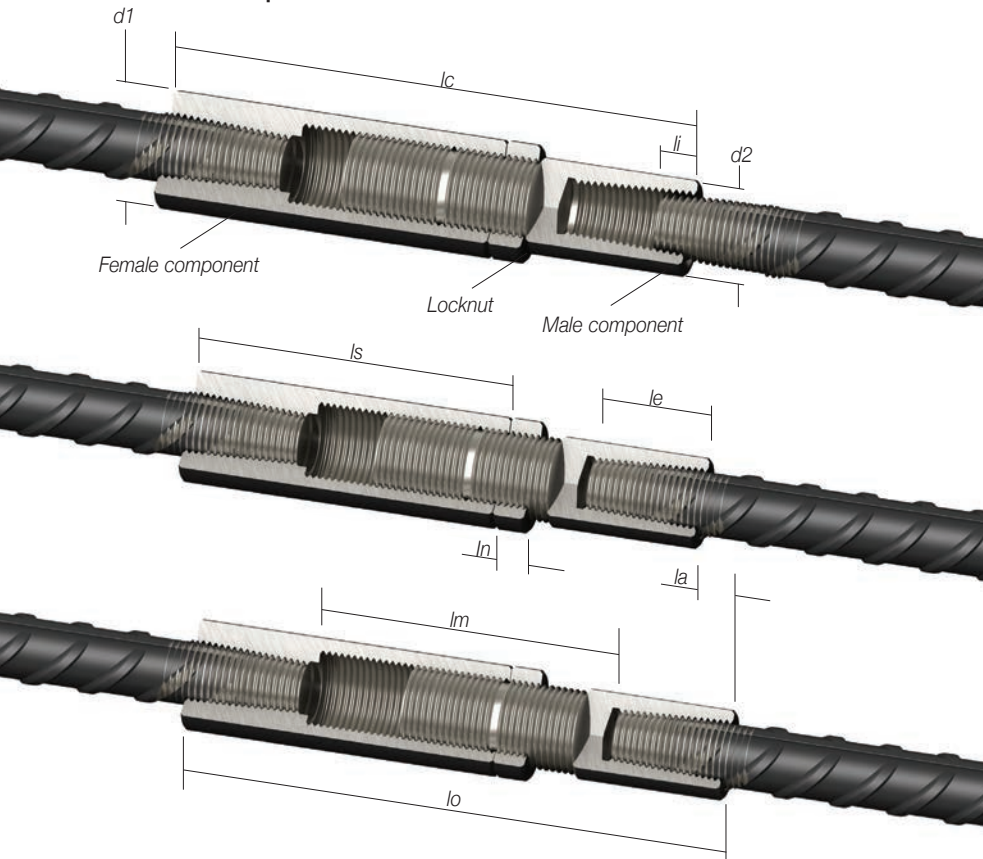

Validate with the CARES Cloud App

Bar Diameter		12	16	20	25	32	40
External Dia.	$d1$	25	30	36	48	55	70
External Dia.	$d2$	22	25	30	36	48	60
Female Sleeve Length	$ls$	84	95	112	132	153	190
Locknut Length	$ln$	13	13	13	13	15	15
Closed Length	$lc$	138	155	180	207	243	296
Max. Open Length	$lo$	178	196	231	266	305	374
Bar Insertion Prior to Engagement	$li$	9	15	8	16	28	40
Bar Insertion Full Engagement	$le$	26	32	33	42	53	66
Adjustable Length	$la$	23	24	26	34	37	52
Max Distance between Bar Ends	$lm$	126	132	165	182	199	242
Weight (kg)		0.44	0.67	1.12	2.21	3.51	6.91
Coupler Torque (Nm)		60	110	165	265	285	330
Locknut Torque (Nm)		20	30	50	70	90	110
Part No.		TTP12	TTP16	TTP20	TTP25	TTP32	TTP40

## Installation

### Tapered Thread Positional Series



The female section of the positional coupler is normally cast flush in the concrete. The installer must take care to protect the internal threads and prevent the ingress of concrete. Once cast and ready to extend, the male end complete with locknut can be screwed into place.



Position the continuation bar as near as possible to the coupler fitted to the cast-in bar.

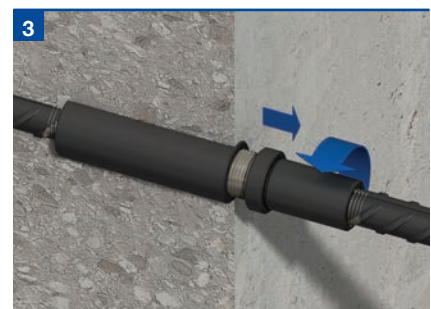

Run the male component and locknut onto the continuation bar until fully engaged.



4  
Using a torque wrench tighten the male component on the continuation bar to the specified torque, whilst holding the continuation bar with a second wrench.



5  
Run the locknut along the threaded barrel of the male component to abut the female section. Using the torque wrench, tighten the locknut to the specified torque. Tightening torques are shown in the table opposite.

At this point the groove in the parallel threaded section of the male component must be completely covered by the locknut. If any part of the groove is visible beyond the locknut, the degree of adjustability has been exceeded and the installation is incorrect.

#### Correct Installation

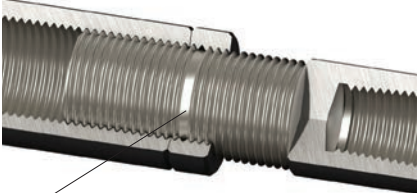

Groove is completely hidden within locknut

#### Incorrect Installation

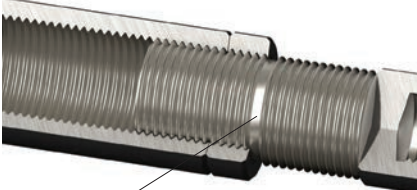

Groove is protruding from locknut

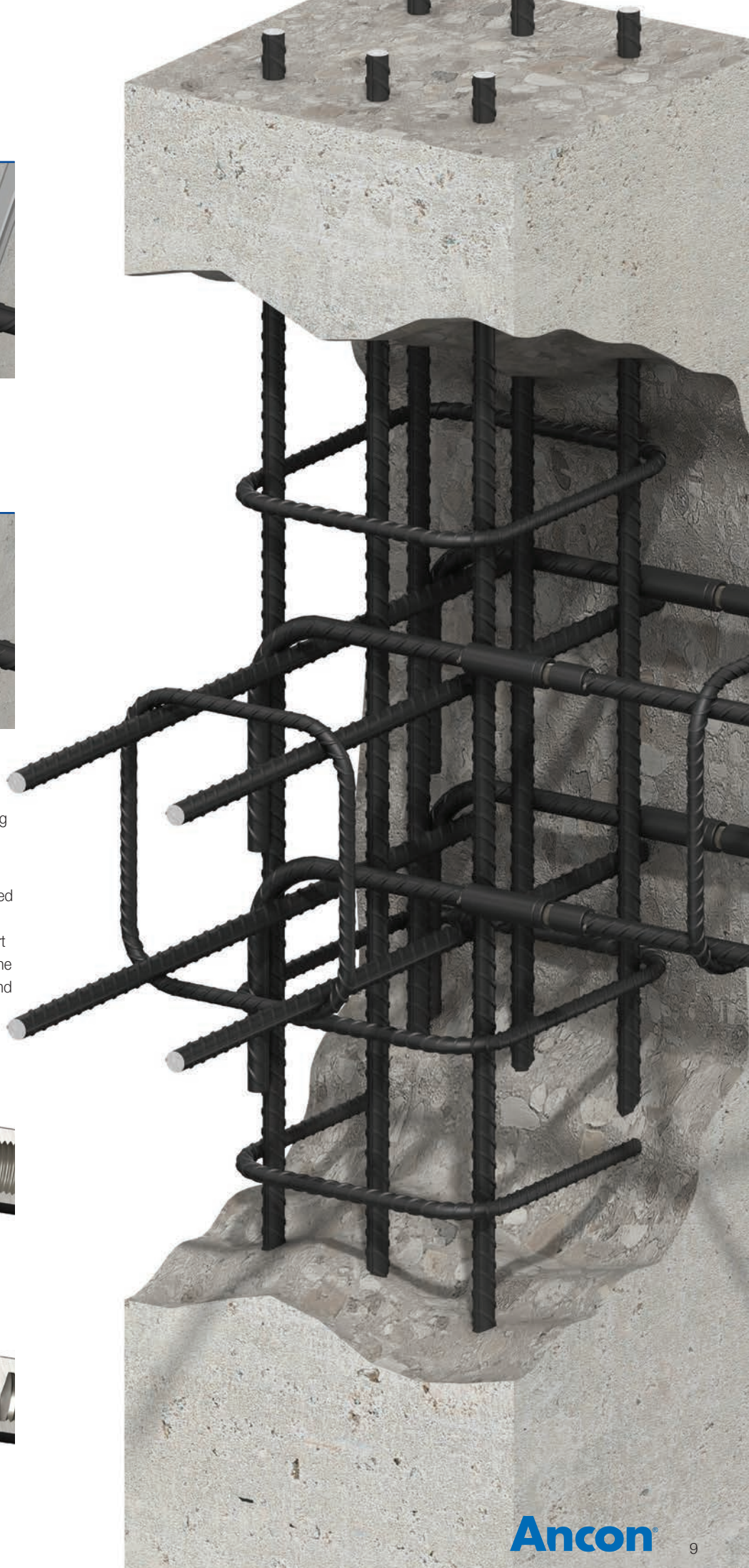

# Reinforcing Bar Couplers

## Transition Coupler

The Ancon Tapered Thread Transition coupler is used to join reinforcing bars of different diameters where one coupler can be rotated.

With all the benefits of the Standard range, Transition couplers are designed to achieve failure loads greater than 115% of the characteristic strength of the smaller diameter grade 500 reinforcing bar. The Transition coupler comprises an internally threaded sleeve with two right hand threads both of which are tapered towards the middle of the coupler. The diameter of each thread corresponds to the appropriate bar size. A nominal +25mm should be allowed per threaded bar end for square cutting the bar end.

## Testing & Approvals

The Transition range of Tapered Thread couplers has been tested and approved by UK CARES to show compliance with the requirements of BS EN 1992-1-1: 2004 (Eurocode 2), BS 8110 and UK CARES TA1-B.



Validate with the CARES Cloud App

## Transition Coupler Dimensions

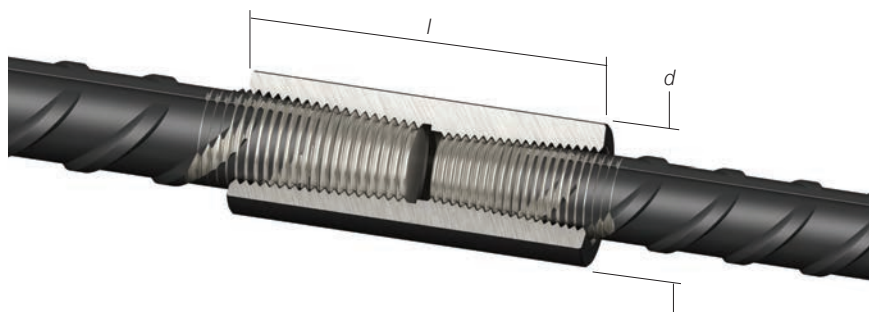

Bar Diameter (mm)	12/16	16/20	20/25	25/32	32/40
External Dia. (mm) $d$	25	30	36	48	55
Coupler Length (mm) $l$	72	78	90	112	138
Weight (kg)	0.21	0.30	0.48	1.11	1.62
Torque (Nm)	60/110	110/165	165/265	265/285	285/330
Part No.	TTT12/16	TTT16/20	TTT20/25	TTT25/32	TTT32/40

## Installation

### Tapered Thread Transition Series

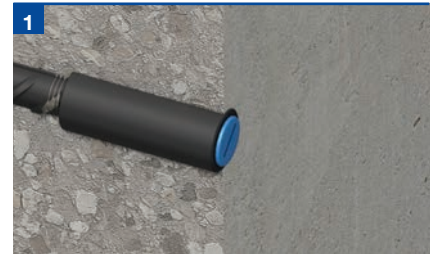

The coupler is normally supplied fixed to a reinforcing bar, ready to be installed and cast in concrete.

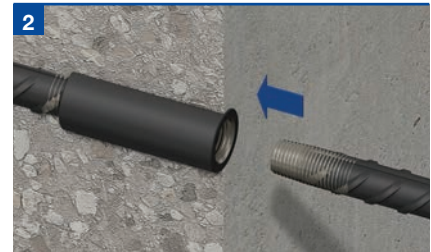

After casting of the concrete and when ready to extend, remove the plastic end cap from the coupler. Position the continuation bar in the sleeve and rotate the bar into the coupler.

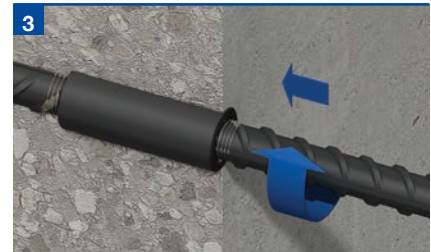

Continue to screw the bar into the coupler until tight.

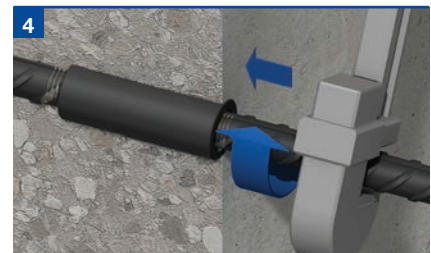

To ensure correct installation, tighten the joint to the specified torque using a calibrated torque wrench on the continuation bar. Tightening torques are shown in the table below.

**Note:** In the event of the coupler being supplied fixed to the smaller bar it is necessary to ensure that when tightening the larger continuation bar, the force is not transmitted through the smaller bar.

## Tapered Thread Weldable Couplers

Ancon Tapered Thread Weldable couplers provide a convenient means of connecting reinforcing bars to structural steel plates or sections. Shorter than the standard coupler, it has a tapered thread at one end. The other end is welded directly to the steel. The couplers are manufactured from either Steel Grade 1045 to ASTM A576 or Steel Grade C45R to EN10083.

The Tapered Thread Weldable coupler is suitable for welding to structural steels, Grade S275 or Grade S355. The load conditions at the connection must be determined by the designer along with the type and size of weld required. Another important consideration is the type of electrode to be used, which must be matched to the properties of the plate and tube, and to the site conditions under which the welding will be undertaken. Welders should be qualified for the type of weld required. As a minimum standard, welding of the couplers shall be in accordance with the guidance provided in the following documents:

BS EN 287-1	Qualification test of welders, Fusion welding, Steels
BS EN 9606-1:2013	Qualification testing of welders, Fusion welding, Steels
BS EN ISO 15607:2003	Specification and qualification of welding procedures for metallic materials. General rules
BS EN ISO 15609-1:2004	Specification and qualification of welding procedures for metallic materials. Welding procedure specification. Arc welding
BS EN ISO 15614-1:2004 + A2:2012	Specification and qualification of welding procedures for metallic materials. Welding procedure test. Arc and gas welding of steels and arc welding of nickel and nickel alloys
BS EN 1011-1:2009 Welding.	Recommendations for welding of metallic materials. General guidance for arc welding
BS EN 1011-2:2001 Welding.	Recommendations for welding of metallic materials. Arc welding of ferritic steels

**Carbon Equivalent Value** - The Carbon Equivalent value of these couplers may typically vary between 0.50 – 0.75, where the carbon equivalent value is given by  
 $CEV = C + (Mn)/6 + (Ni+Cu)/15 + (Cr+Mo+V)/5$

For further assistance and technical information please contact us.

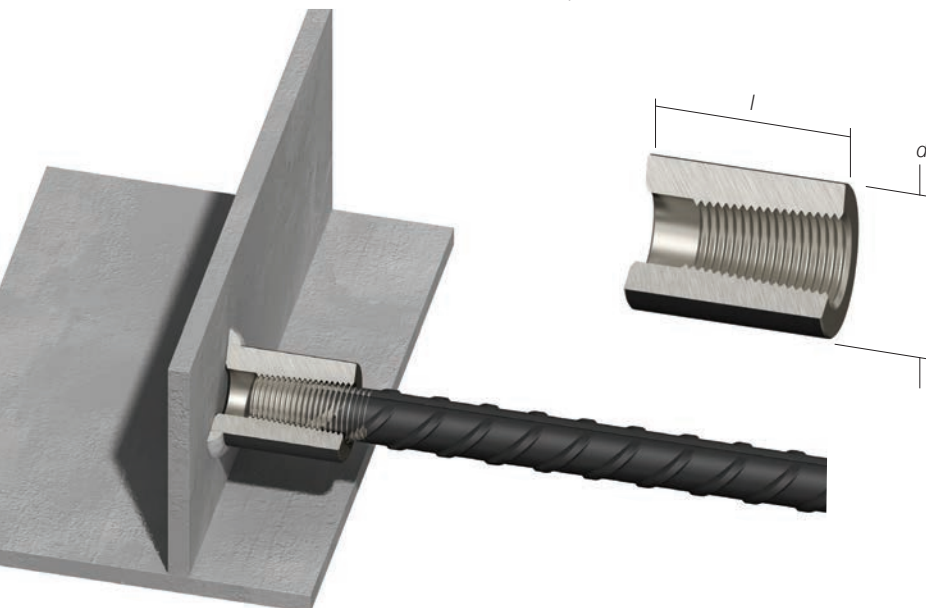

### Weldable Coupler Dimensions

Bar Diameter (mm)	12	16	20	25	32	40
External Dia. (mm) <i>d</i>	25	30	36	48	55	70
Coupler Length (mm) <i>l</i>	35	42	47	57	72	89
Weight (kg)	0.11	0.18	0.28	0.63	0.97	1.97
Torque (Nm)	60	110	165	265	285	330
Part No.	TTW12	TTW16	TTW20	TTW25	TTW32	TTW40

## Installation

### Tapered Thread Weldable Couplers

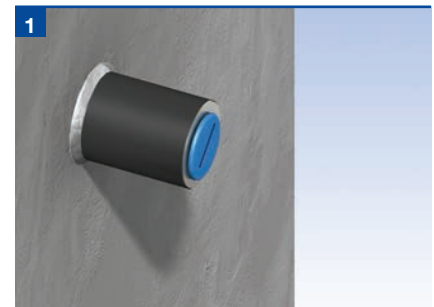

The coupler must first be welded to the steelwork.

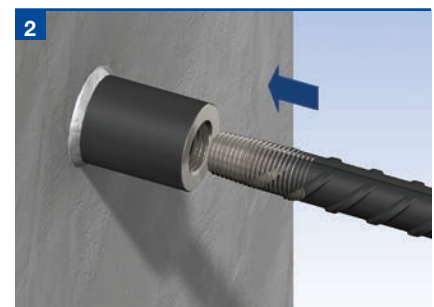

When ready to extend, remove the plastic end cap and position the continuation bar into the sleeve.

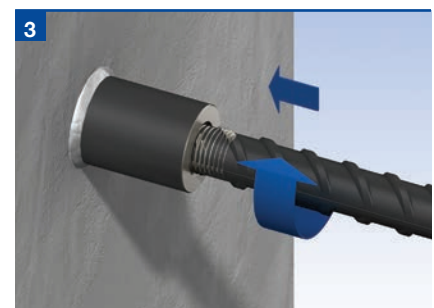

Rotate the bar into the coupler until tight.

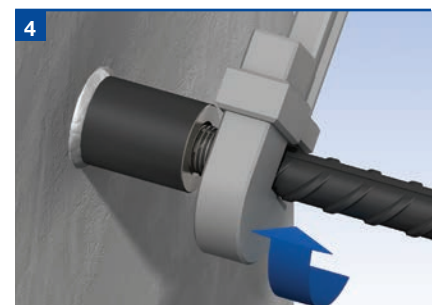

To ensure correct installation, tighten the joint to the specified torque using a calibrated torque wrench on the continuation bar. Tightening torques are shown in the table.

# Reinforcing Bar Couplers

## Tapered Thread Headed Anchors

The Tapered Thread Headed Anchor provides an effective method of achieving rebar end anchorage within concrete.

Anchorage of rebars within a concrete section is traditionally achieved by means of creating a long hooked end on the rebar. This can lead to problems when positioning the bar and can increase congestion. It can ultimately result in larger than necessary concrete sections at the location of the hooked ends.

Consisting of an oversized coupler, the Tapered Thread Headed Anchor carries the full tension load of the bar when it is bearing against the concrete. The Headed Anchor removes the need for hooked rebar and subsequently reduces congestion and simplifies bar placement. This in turn increases speed of construction and gives greater flexibility in design. Typical applications include pile caps and beam to column connections.

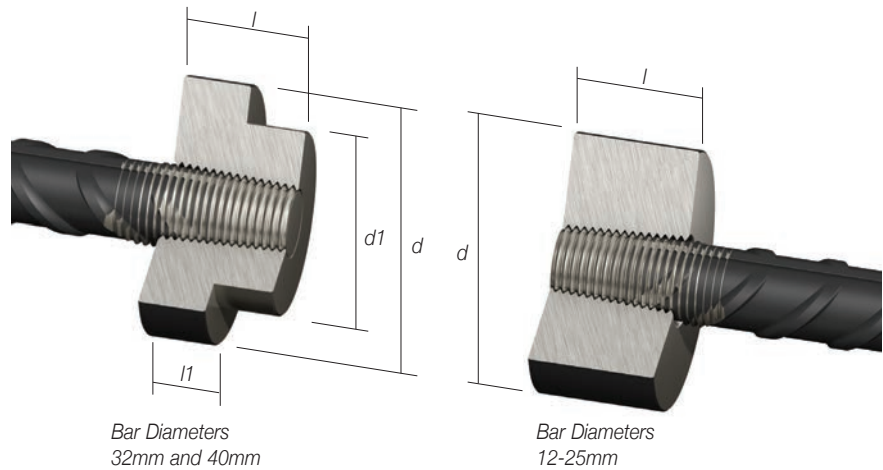

### Tapered Thread Headed Anchor Dimensions

Bar Diameter (mm)	12	16	20	25	32	40
External Dia. (mm) <i>d</i>	40	50	65	80	110	135
External Dia. (mm) <i>d1</i>	-	-	-	-	78	78
Coupler Length (mm) <i>l</i>	27.0	33.0	35.0	43.5	53.5	67.5
Coupler Length (mm) <i>l1</i>	-	-	-	-	28.5	42.5
Weight (kg)	0.25	0.46	0.83	1.57	2.81	5.17
Torque (Nm)	60	110	165	265	285	330
Part No.	TTH12	TTH16	TTH20	TTH25	TTH32	TTH40

**Note:** Where tapered thread headed anchors are used, the compressive strength of the concrete shall not be less than strength grade C32/40 (cylinder/cube).

## Tapered Thread Parallel Thread Adaptors

The TTA Tapered Thread Parallel Thread Adaptor accepts a standard metric bolt or studing.

It is particularly useful for connecting temporary fixtures to concrete. Once the fixture is removed, reinforcement continuity can be achieved in the second phase construction by using another TTA adaptor and central threaded stud. The TTA is designed to achieve failure loads in excess of 115% of the characteristic strength of grade 500 rebar and meets the requirements of BS EN 1992-1-1:2004 (Eurocode 2) and BS 8110 for mechanical splices.



### Tapered Thread Parallel Thread Adaptor Dimensions

Bar Diameter (mm)	12	16	20	25	32
External Dia. (mm) <i>d</i>	25	28	36	42	55
Coupler Length (mm) <i>l</i>	56	68	78	95	115
Parallel Thread Length (mm) <i>lp</i>	24	30	36	45	54
Parallel Thread Size <i>dp</i>	M16x2.0	M20x2.5	M24x3.0	M30x3.5	M36x4.0
Weight (kg)	0.14	0.21	0.40	0.61	1.37
Torque (Nm)	60	110	165	265	285
Part No.	TTA12	TTA16	TTA20	TTA25	TTA32

## Accessories

### Threading Machine

The Ancon threading machine provides a fast, simple and reliable threading operation. The machine is compact, making it completely portable and easy to locate. It is of a robust design to provide a long, low maintenance life.

Threading machines are generally located in stockists' yards. For larger projects our machines can be made available for hire. Please contact Leviat for further information.

Training on the correct usage of the threading machine is provided by our technicians.

### Machine Consumables

The following consumables are available:

#### Chaser Sets

Chaser sets are available on a regrindable or disposable basis. Each set can be reground up to 3 times in order to extend cutting life. Please contact us for details.

### Coolant

We recommend the use of Pencil S900 Cutting Fluid or a similar water based coolant.

### Thread Protectors

Plastic sleeves are available to protect the tapered threads on reinforcing bars.

### Torque Wrenches

In order to ensure the correct assembly of tapered thread couplers the use of a calibrated torque wrench is essential. Details of wrenches are included in the table below. Each Ancon wrench is supplied with a certificate of calibration.



### Torque Wrenches

#### Torque Wrenches for Couplers and Locknuts

Part No.	E879008	E879009	E879010
Torque (Nm)	60 - 285	85 - 350	20 - 90

### Torque Values (Nm)

Bar Diameter (mm)	12	16	20	25	32	40
Standard Coupler	60	110	165	265	285	330
Positional Coupler	60	110	165	265	285	330
Positional Locknut	20	30	50	70	90	110
Bar Diameter (mm)	12/16	16/20	20/25	25/32	32/40	
Transition Coupler	60/110	110/165	165/265	265/285	285/330	

## BT Stainless Steel Couplers

The Ancon range of couplers is predominantly designed for the joining of carbon steel bars, however when stainless steel reinforcement is being used the Ancon BT-S coupler is ideal. These couplers are manufactured from 1.4462 duplex stainless steel for optimum strength and corrosion resistance. They are suitable for projects of any size where the strength of the connection is required to match or exceed that of the parent bars, including large scale, high volume coupler applications.

The end of each bar to be joined is cut square and enlarged by cold forging. This increases the core diameter of the bar to ensure that the joint is stronger than the bar.

Parallel metric threads are formed onto the bar ends. The threaded end can be proof tested

to a force equal to the characteristic yield strength of the bar.

The couplers are suitable for splicing BS 6744 Grade 500 stainless steel reinforcing bars.

For further information please contact us.



### BT-S Couplers

Bar Diameter (mm)	16	20	25	32	40
External Diameter (mm)	30	35	42	52	65
Coupler Length (mm)	40	48	60	72	90
Thread Form	M20 x 2.5	M24 x 3.0	M30 x 3.5	M36 x 4.0	M45 x 4.5
Weight (kg)	0.14	0.22	0.37	0.72	1.37
Coupler Reference	BTS16	BTS20	BTS25	BTS32	BTS40

### BT-S Locknuts

Bar Diameter (mm)	16	20	25	32	40
External Diameter (mm)	30	35	42	52	65
Locknut Length (mm)	13	16	20	24	30
Thread Form	M20 x 2.5	M24 x 3.0	M30 x 3.5	M36 x 4.0	M45 x 4.5
Weight (kg)	0.05	0.07	0.12	0.24	0.46
Coupler Reference	BTS16LN	BTS20LN	BTS25LN	BTS32LN	BTS40LN

Type A connections use an internal plastic cap to protect the thread in the coupler. In cases such as deep concrete pours, additional protection may be required to prevent the ingress of concrete fines.

### BT Stainless Steel Type A

The Type A connection utilises an internally threaded coupler to join two cold-forged and threaded bar ends together. Each bar end is threaded to half the length of the coupler. Type A connections are used where the continuation bar can be rotated.

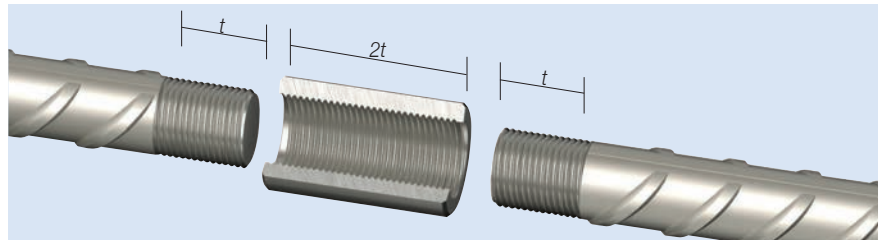

### BT Stainless Steel Type B

The Type B connection utilises the same coupler as for the Type A, the difference being one bar end is threaded for the full coupler length. Type B connections are used where the continuation bar can be rotated for no more than one revolution.

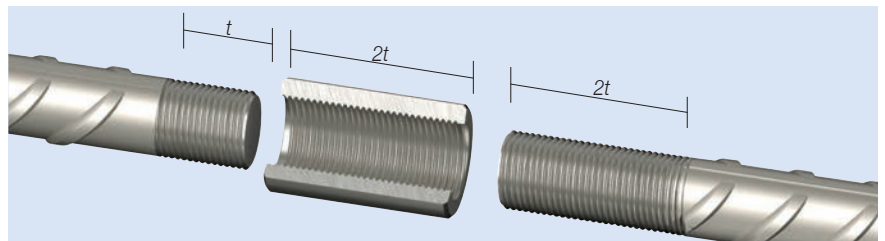

### BT Stainless Steel Type C

The Type C connection utilises the same coupler as for the Type A, together with locknuts and longer threads to the bar ends. Type C connections are used where the continuation bar cannot be rotated.

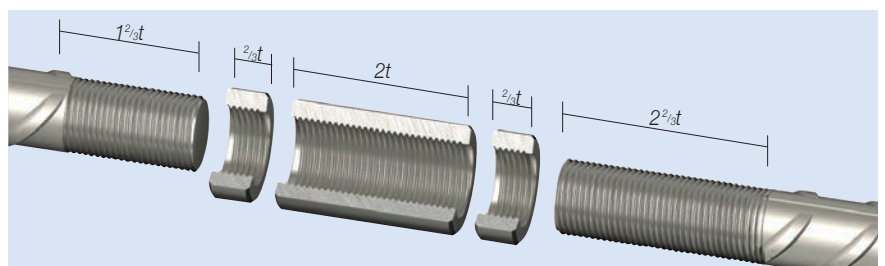

# Reinforcing Bar Couplers

## Bartec Plus

Bartec Plus couplers offer a full strength connection together with enhanced fatigue resistance, yet are the smallest in the Ancon range. They are suitable for projects of any size, including those requiring a high volume of couplers, such as road and rail bridges.

Each end of the rebar to be joined is cut square and enlarged using a cold forge process. A thread is then formed on the enlarged bar end using a thread rolling machine. The thread is such that the cross-sectional area of the bar ends are not reduced ensuring the strength of the connection matches or exceeds that of the parent bars.

It is the application of the rolled thread that differentiates Bartec Plus from other threaded rebar systems. Each thread-rolled bar end is proof-loaded to a force equal to the characteristic yield strength of the rebar. It is the combination of these processes that provide the connection with enhanced fatigue resistance.

Ancon Bartec Plus Type A Standard Couplers in the size range 12mm to 40mm and Type C Positional Couplers in the size range 12mm to 40mm have been evaluated by UK CARES Technical Approval TA1-A for use as follows:

- a) TA1-B: Eurocode 2 and BS 8110 for static applications in tension only with BS4449 Grade B500B and B500C reinforcement
- b) TA1-A: Class D fatigue requirements with BS4449 Grade B500B and B500C reinforcement.



Validate with the CARES Cloud App

Types A and C, in the bar diameters below, are compliant with BS 8597: 2015.

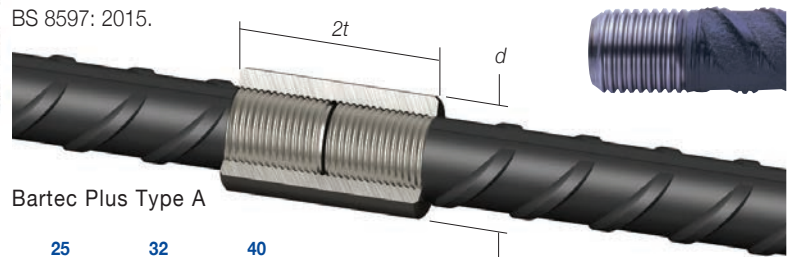

Bartec Plus Type A

### Bartec Plus Couplers

Bar Diameter (mm)	12	16	20	25	32	40
External Diameter (mm) $d$	20.6	26.4	32.1	40.1	49.5	67.5
Coupler Length (mm) $2t$	28	40	48	60	72	90
Thread Form	M14x2.0	M20x2.5	M24x3.0	M30x3.5	M36x4.0	M45x4.5
Weight (kg)	0.05	0.09	0.16	0.31	0.57	1.53
Coupler Reference	BTP12	BTP16	BTP20	BTP25	BTP32	BTP40

Other sizes are available on request. Contact us for more details. Thread incompatible with standard metric bolts/studs.

### Bartec Plus Locknuts

Bar Diameter (mm)	12	16	20	25	32	40
External Diameter (mm)	20.6	26.4	32.1	40.1	49.5	67.5
Locknut Length (mm)	12	13	16	20	24	30
Thread Form	M14x2.0	M20x2.5	M24x3.0	M30x3.5	M36x4.0	M45x4.5
Weight (kg)	0.02	0.04	0.05	0.10	0.19	0.50
Locknut Reference	BTP12LN	BTP16LN	BTP20LN	BTP25LN	BTP32LN	BTP40LN

Other sizes are available on request. Contact us for more details. Thread incompatible with standard metric bolts/studs.

Type A connections use an internal plastic cap to protect the thread in the coupler. In cases such as deep concrete pours, additional protection may be required to prevent the ingress of concrete fines. For 40mm Type C connections, the diameter of the locknuts will be marginally smaller than that of the BTP40 coupler.

### Bartec Plus Type A

The Type A connection utilises an internally threaded coupler to join two cold-forged and thread-rolled bar ends together. Each bar end is threaded to half the length of the coupler. Type A connections are used where the continuation bar can be rotated.

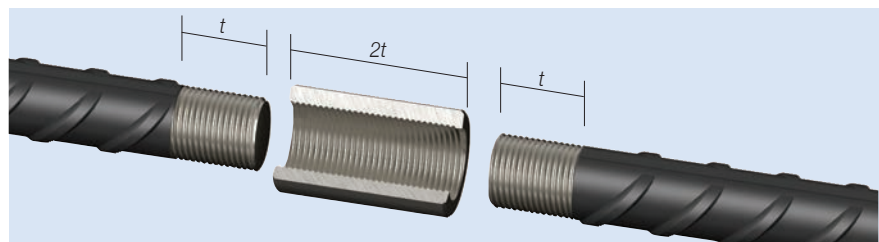

### Bartec Plus Type B

The Type B connection utilises the same coupler as for the Type A, the difference being one bar end is threaded for the full coupler length. Type B connections are used where the continuation bar can be rotated for no more than one revolution.

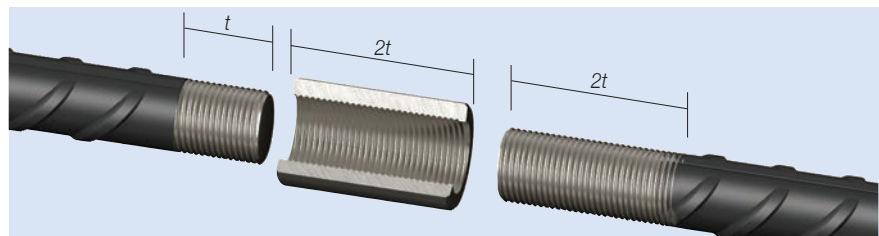

### Bartec Plus Type C

The Type C connection utilises the same coupler as for the Type A, together with locknuts and longer threads to the bar ends. Type C connections are used where the continuation bar cannot be rotated.

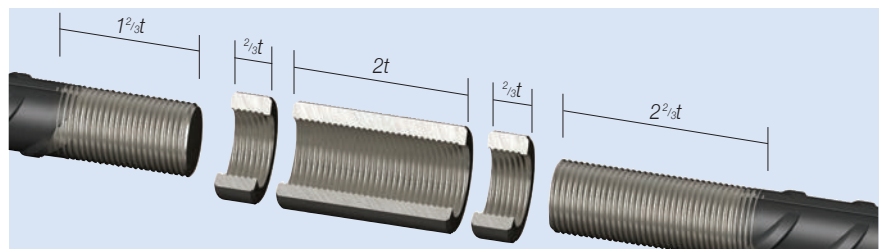



**Installation**  
**Bartec Plus Type A**

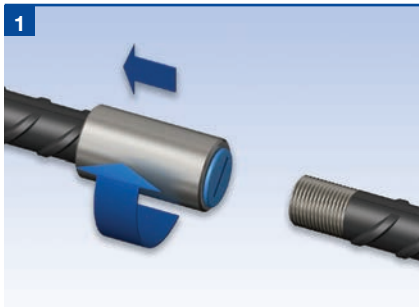

Run the coupler to the end of the thread on the fixed bar.

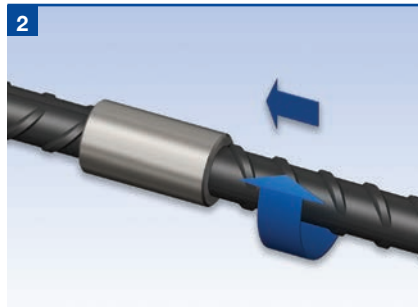

Remove the plastic cap from the coupler. Position and rotate the continuation bar in the coupler.

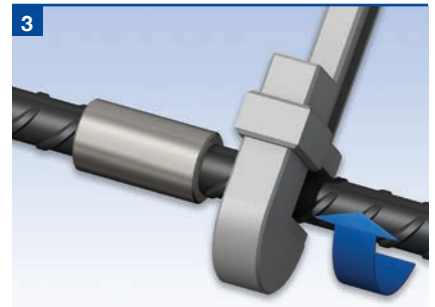

Tighten the joint using a wrench on the continuation bar.



**Bartec Plus Type B**

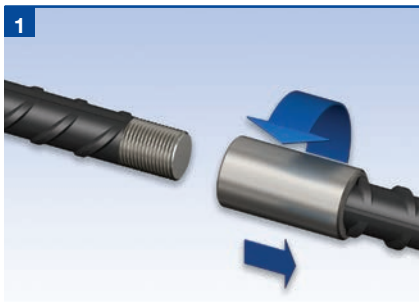

Run the coupler to the end of the thread on the continuation bar.

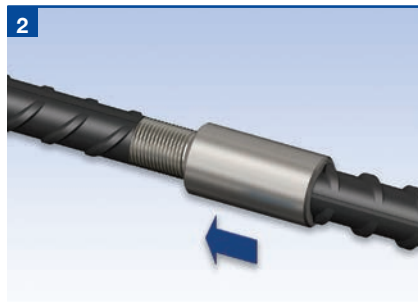

Position the continuation bar with the coupler against the end of the fixed bar.

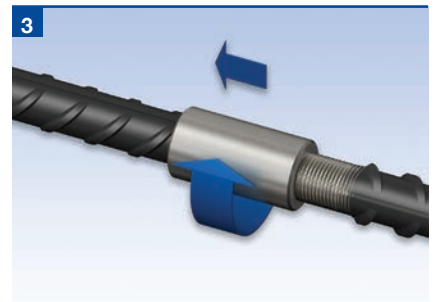

Run the coupler from the continuation bar onto the fixed bar.

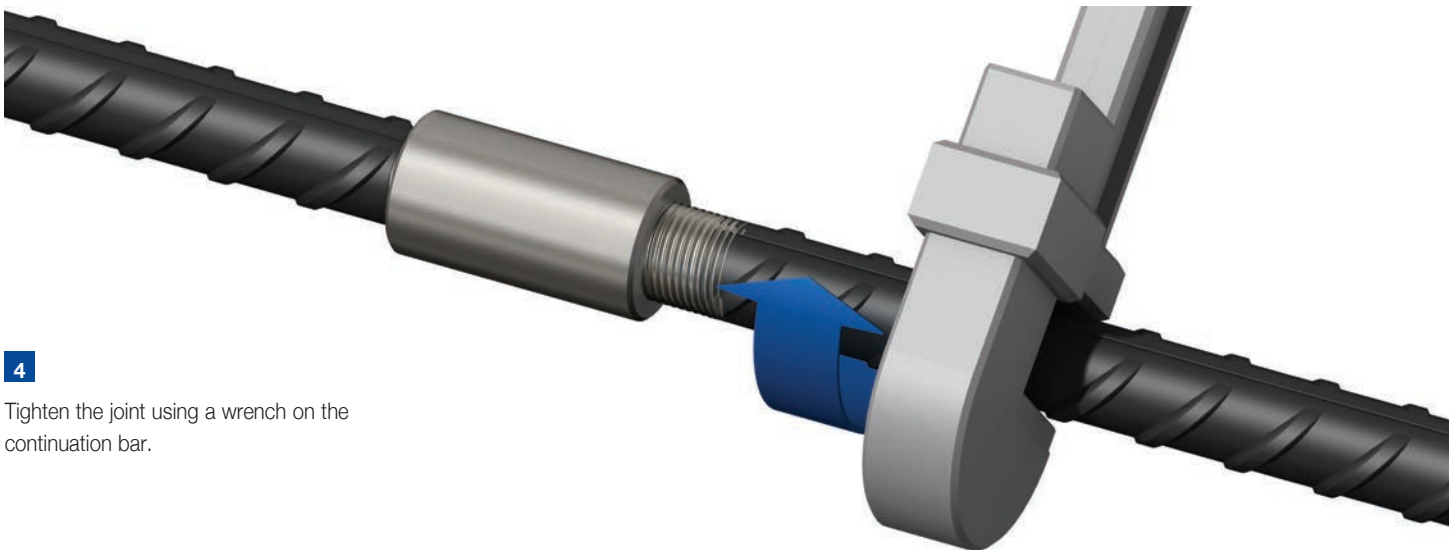

**4**  
Tighten the joint using a wrench on the continuation bar.

# Reinforcing Bar Couplers

## Installation

### Bartec Plus Type C

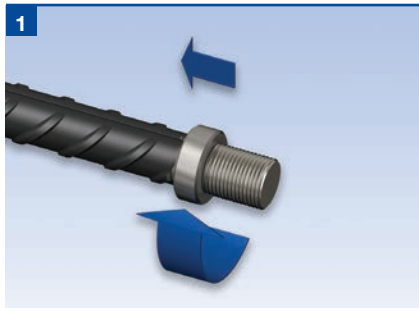

Run the locknut onto the fixed bar.

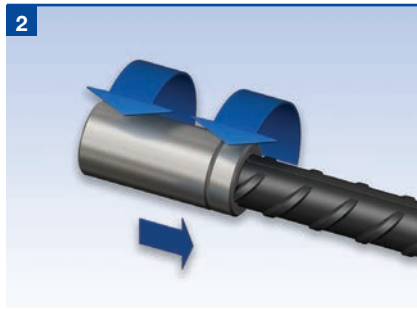

Run the second locknut followed by the coupler to the end of the thread on the continuation bar.



Position the continuation bar with the coupler against the end of the fixed bar.

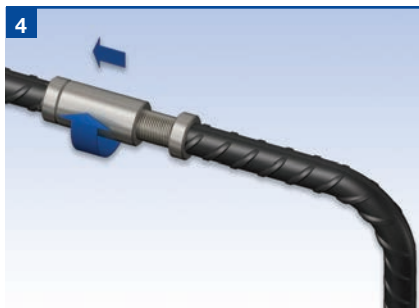

Run the coupler from the continuation bar onto the fixed bar and using a wrench lock tight against the locknut.

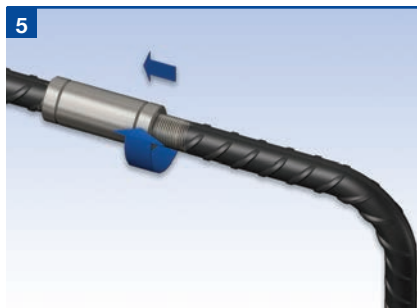

Run the locknut along the continuation bar to abut the coupler and lock tight with a wrench.

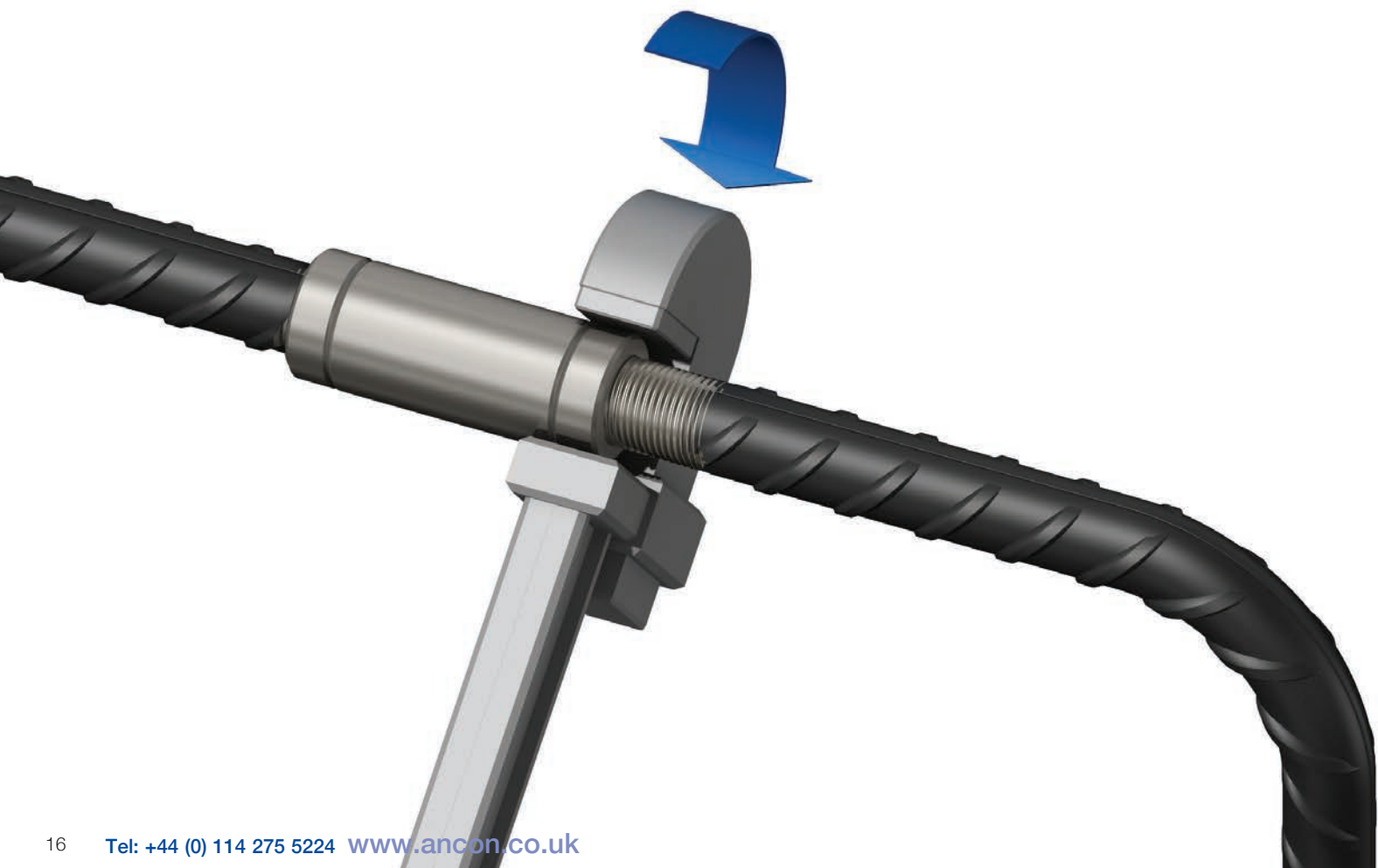

## Bartec Plus Transition Couplers\*

Bartec Plus couplers can be used to connect reinforcing bars of differing diameters, developing the full tensile strength of the smaller diameter bar together with the enhanced fatigue resistance.

For Type A transition connections, both bars utilise standard Type A Bartec Plus threads with a special coupler to connect the two bars.

Transition connections requiring types B or C systems use the standard Bartec Plus thread for the smaller bar and a modified BT thread for the larger bar which uses a thread pitch matching the smaller thread to allow simultaneous rotation of the coupler on both bars.

Locknuts for Type C connections use the standard locknut for the smaller bar and a

modified locknut with the modified thread pitch for the larger bar.

The threads are such that the cross-sectional area of the bar ends are not reduced beyond that of the smaller diameter bar, thus ensuring the strength of the connection matches or exceeds that of the smaller bar.

As with Bartec Plus standard coupler systems, each enlarged and thread-rolled bar end is proof-loaded to a force equal to the characteristic yield strength of the rebar. It is the combination of these processes that

provide the connection with an enhanced fatigue resistance.

Type A connections use an internal plastic cap to protect the thread in the coupler. In cases such as deep concrete pours, additional protection maybe required to prevent the ingress of concrete fines. For 40mm Type C connections, the diameter of the locknuts will be marginally smaller than that of the BTP40 coupler.

### Bartec Plus Transition Couplers

Bar Diameter (mm)	12/16	16/20	20/25	25/32	32/40
External Diameter (mm) $d$	20.6	26.4	32.1	40.1	53
Coupler Length (mm) $2t$	28	40	48	60	72
Thread Form	M14x2.0/M20x2.5	M20x2.5/M24x3.0	M24x3.0/M30x3.5	M30x3.5/M36x4.0	M36x4.0/M40x4.0
Weight (kg)	0.05	0.09	0.16	0.31	0.67
Coupler Reference	BTP12/16	BTP16/20	BTP20/25	BTP25/32	BTP32/40

Other sizes are available on request. Contact us for more details. Thread incompatible with standard metric bolts/studs.

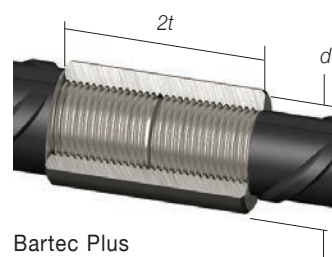

Bartec Plus Transition Type A

### Bartec Plus Transition Locknuts

Bar Diameter (mm)	12/16	16/20	20/25	25/32	32	40
External Diameter (mm)	20.6	26.4	32.1	40.1	49.5	53
Locknut Length (mm)	28	13	16	20	24	30
Thread Form	M14x2.0/M20x2.5	M20x2.5/M24x3.0	M24x3.0/M30x3.5	M30x3.5/M36x4.0	M36x4.0	M40x4.0
Weight (kg)	0.02	0.04	0.05	0.10	0.19	0.26
Locknut Reference	BTP12/16LN	BTP16/20LN	BTP20/25LN	BTP25/32LN	BTP32LN	BTP40LN

Other sizes are available on request. Contact us for more details. Thread incompatible with standard metric bolts/studs.

### Bartec Plus Transition Type A

The Type A connection utilises an internally threaded coupler to join two cold-forged and thread-rolled bar ends together. Each bar end is threaded to half the length of the coupler. Type A connections are used where the continuation bar can be rotated.

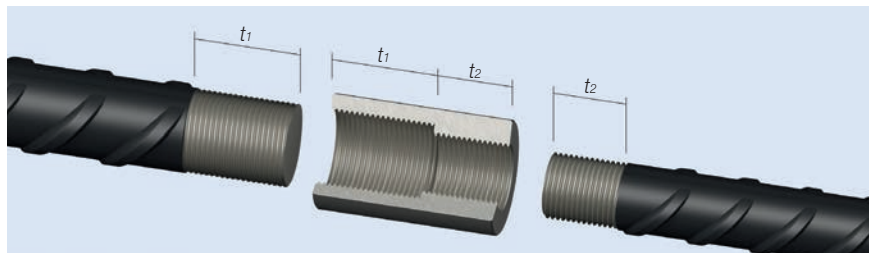

### Bartec Plus Transition Type B

The Type B connection utilises the same coupler as for the Type A, the difference being one bar end is threaded for the full coupler length. It is usual to rotate the coupler from the smaller diameter rebar onto the larger. Type B connections are used where the continuation bar can be rotated for no more than one revolution.

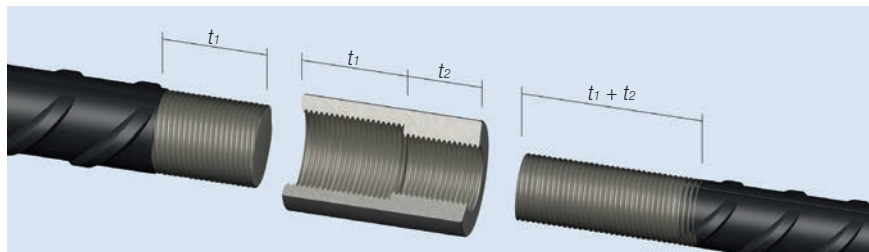

### Bartec Plus Transition Type C

The Type C connection utilises the same coupler as for the Type A, together with two locknuts and longer threads on the bar ends. It is usual to rotate the coupler from the smaller diameter rebar onto the larger. Type C connections are used where the continuation bar cannot be rotated.

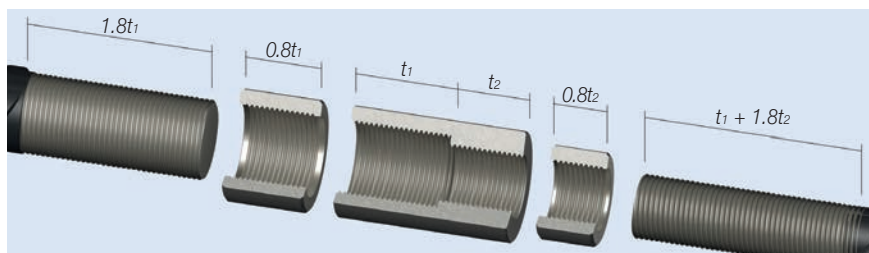

\*This detail is to be used with micro-alloy / through hardened rebar only, as threading directly onto rebar produced using the quench and temper or thermo-mechanically-treated methods may result in a disproportionate loss of strength.

# Reinforcing Bar Couplers

## Installation

### Bartec Plus Transition Type A

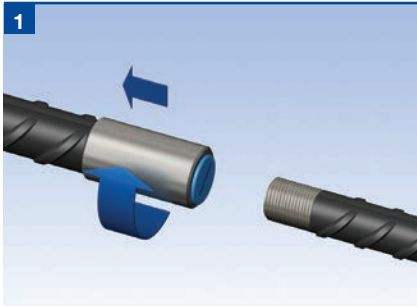

1 Run the coupler to the end of the thread on the fixed bar.

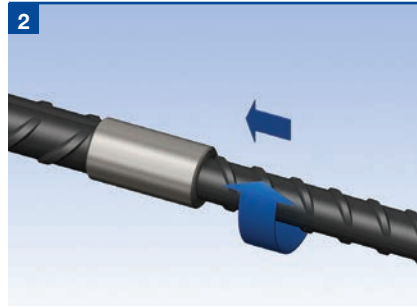

2 Remove the plastic cap from the coupler. Position and rotate the continuation bar in the coupler.

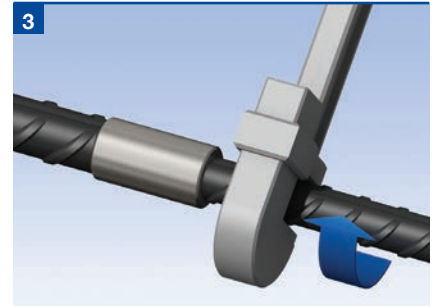

3 Tighten the joint using a wrench on the continuation bar.

### Bartec Plus Transition Type B

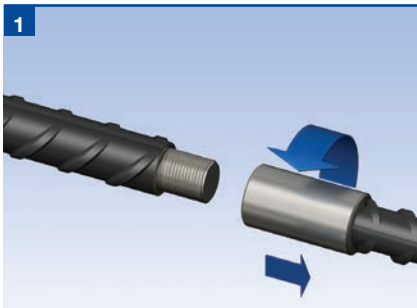

1 Screw the coupler to fully engage on the long thread of the smaller diameter bar.

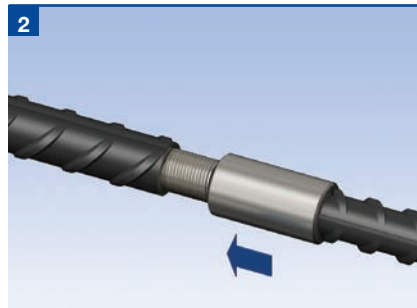

2 Position the continuation bar with the coupler against the end of the larger diameter bar.

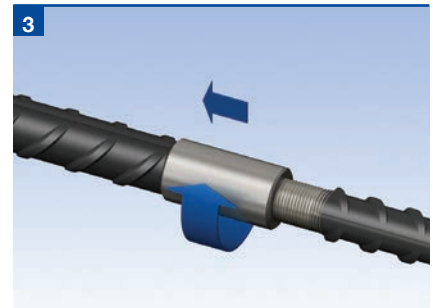

3 Rotate the coupler from the smaller diameter bar to engage against the rear of the thread on the opposing bar and lock tight with a wrench.

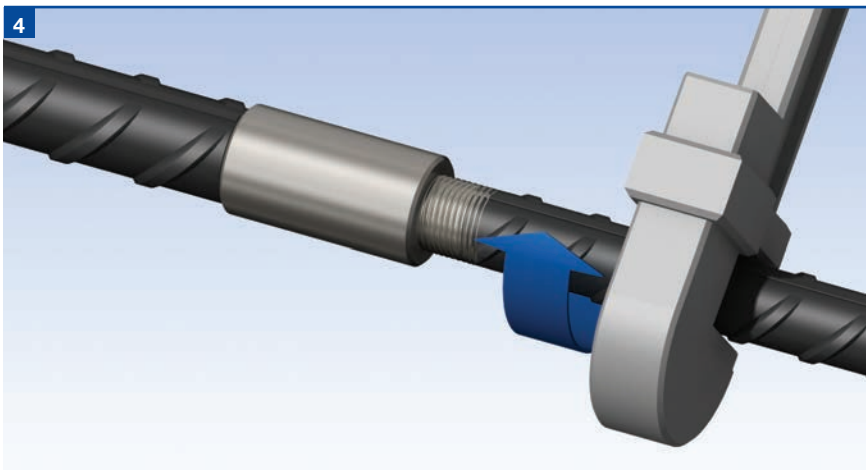

4 Using a wrench, rotate the continuation bar to lock the two bar ends against each other within the coupler. After tightening, the length of exposed thread should be no more than half of the coupler length plus 2-4mm depending on the diameter of the rebar.



**Installation**  
**Bartec Plus Transition Type C**

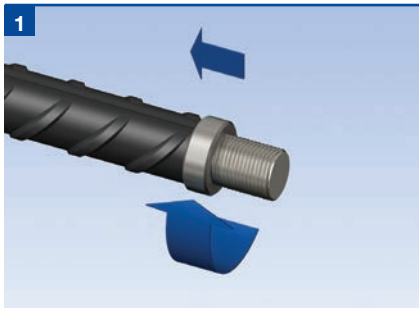

1 Screw the locknut to engage on the rear of the thread on the larger diameter bar and tighten using a wrench.

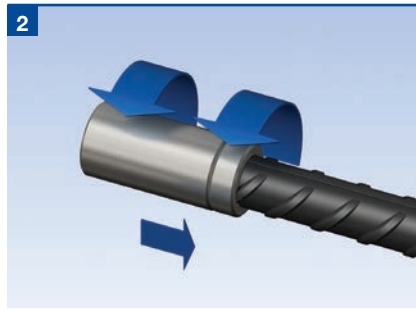

2 Screw the locknut followed by the coupler to fully engage on the long thread of the smaller diameter bar.

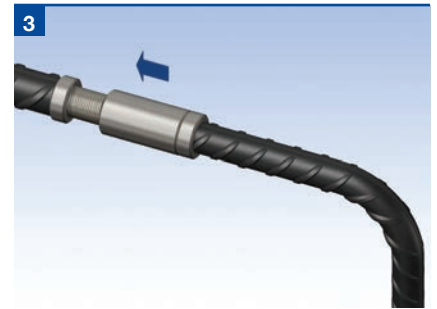

3 Position the smaller diameter bar with the coupler against the end of the larger diameter bar.



4 Rotate the coupler from the smaller diameter bar and using a wrench, lock tight against the locknut on the larger diameter rebar.

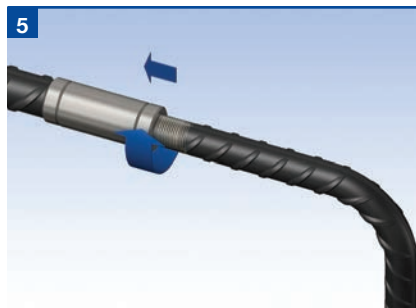

5 Rotate the locknut on the smaller diameter rebar and using a wrench, lock tight against the coupler.



# Reinforcing Bar Couplers

## Bartec Plus Weldable Couplers

Bartec Plus welded couplers provide a convenient means of connecting reinforcing bars to structural steel plates or sections. One end has the Bartec Plus thread form; the other end is prepared for welding to the steel.

The coupler is suitable for welding to structural steels EN BS 10025, Grade S275 (43A) or Grade S355 (Grade 50B), however the load conditions at the connection must be determined by the designer responsible for this structural element, along with the type and size of weld required. Other important considerations are the type of electrode to be used, which must be matched to the properties of the plate and tube, and to the site conditions under which the welding will be undertaken. Welders should be qualified for the type of weld required.

As a minimum standard, welding of the couplers shall be in accordance with the guidance provided in the following documents:

BS EN 287-1	Qualification test of welders, Fusion welding, Steels
BS EN 9606-1:2013	Qualification testing of welders, Fusion welding, Steels
BS EN ISO 15607:2003	Specification and qualification of welding procedures for metallic materials. General rules
BS EN ISO 15609-1:2004	Specification and qualification of welding procedures for metallic materials. Welding procedure specification. Arc welding
BS EN ISO 15614-1:2004 + A2:2012	Specification and qualification of welding procedures for metallic materials. Welding procedure test. Arc and gas welding of steels and arc welding of nickel and nickel alloys
BS EN 1011-1: 2009 Welding.	Recommendations for welding of metallic materials. General guidance for arc welding
BS EN 1011-2:2001 Welding.	Recommendations for welding of metallic materials. Arc welding of ferritic steels

Bartec Plus Weldable Couplers are manufactured from either Steel Grade 1045 to ASTM A576 or Steel Grade C45R to EN10083.

**Carbon Equivalent Value** - The Carbon Equivalent value of these couplers may typically vary between 0.50 – 0.75, where the carbon equivalent value is given by  
 $CEV = C + (Mn)/6 + (Ni+Cu)/15 + (Cr+Mo+V)/5$

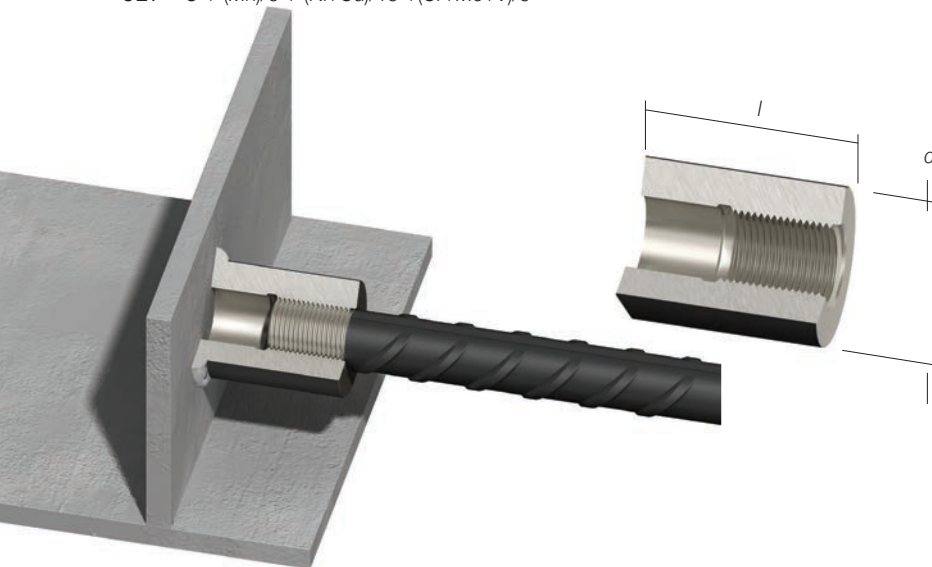

### Bartec Plus Weldable Couplers

Bar Diameter (mm)	12	16	20	25	32	40	
Coupler Diameter (mm)	<i>d</i>	28	33	38	48	57	72
Coupler Length (mm)	<i>l</i>	28	40	48	60	72	90
Thread Form	M14x2.0	M20x2.5	M24x3.0	M30x3.5	M36x4.0	M45x4.5	
Weight (kg)	0.1	0.18	0.30	0.58	0.96	1.91	
Coupler Reference	BTP12W	BTP16W	BTP20W	BTP25W	BTP32W	BTP40W	

**Note:** Thread incompatible with standard metric bolts/studs.

### Installation

#### Bartec Plus Weldable Couplers

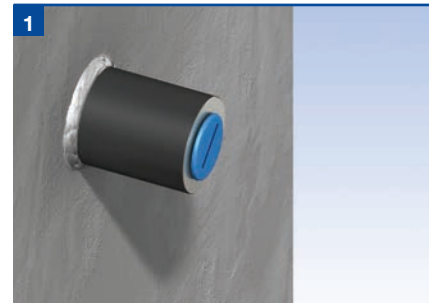

The coupler must first be welded to the steelwork.

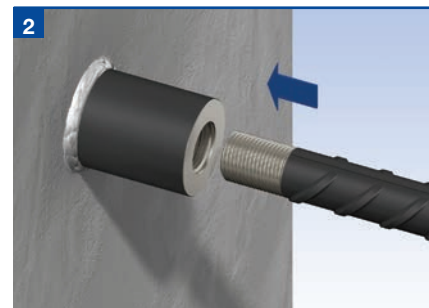

When ready to extend, remove the plastic end cap and position the continuation bar into the sleeve.

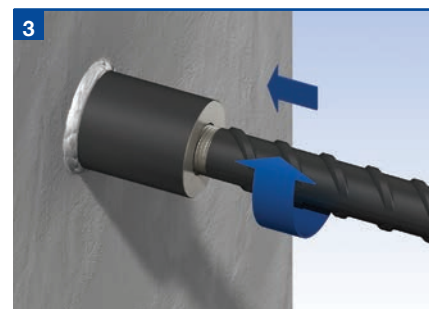

Rotate the bar into the coupler until tight.

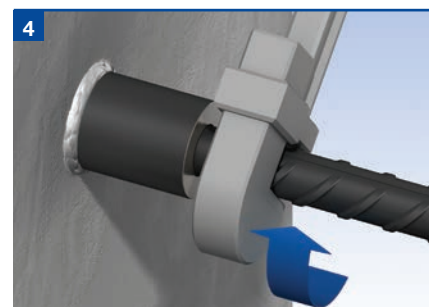

Tightening the continuation bar using a wrench.

## Bartec Plus Headed Anchors

The Bartec Plus Headed Anchor provides an effective and proven method of achieving rebar end anchorage within concrete.

Anchorage of reinforcement within a concrete section is traditionally achieved by means of creating a long hooked end to the bar. These hooks can lead to problems when positioning the bar and can increase congestion. It can ultimately result in larger than necessary concrete sections at the location of hooked ends.

The Bartec Plus Headed Anchor is essentially an oversized coupler capable of carrying the full tension load of the bar when it bears against the concrete in which it is cast. The Headed Anchor removes the need for the hooked rebar end and subsequently reduces congestion, simplifying bar placement. This in turn increases the speed of construction and gives greater flexibility in design. Typical applications include pile caps and beam-to-column connections.

To attach the Headed Anchor to the rebar, it is first necessary to enlarge the bar end and then form the thread on the enlarged bar end using a thread rolling machine. As with the conventional coupler connection, the thread is such that the cross-sectional area of the bar end is not reduced, thus ensuring the strength of the connection matches or exceeds that of the parent bar.

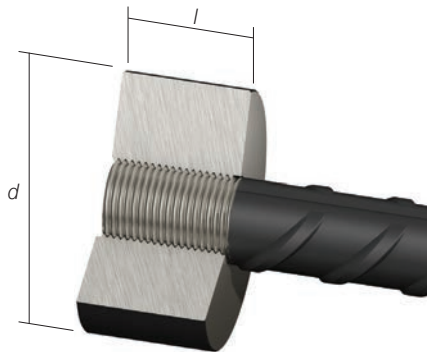

### Bartec Plus Headed Anchors

Bar Diameter (mm)	12	16	20	25	32	40
External Diameter (mm) <i>d</i>	40	50	65	80	110	135
Anchor Thickness (mm) <i>l</i>	15	20	24	30	36	45
Thread Form	M14x2.0	M20x2.5	M24x3.0	M30x3.5	M36x4.0	M45x4.5
Weight (kg)	0.13	0.27	0.56	1.03	2.43	4.55
Anchor Reference	BTP12HA	BTP16HA	BTP20HA	BTP25HA	BTP32HA	BTP40HA

Other sizes are available on request. Contact us for more details. Thread incompatible with standard metric bolts/studs.

### Concrete Strength

When the above sizes of Bartec Plus Headed Anchors are used, the compressive strength of the concrete shall not be less than strength grade C32/40 (cylinder/cube). Where required, Headed Anchors can be supplied to a larger diameter than shown above.

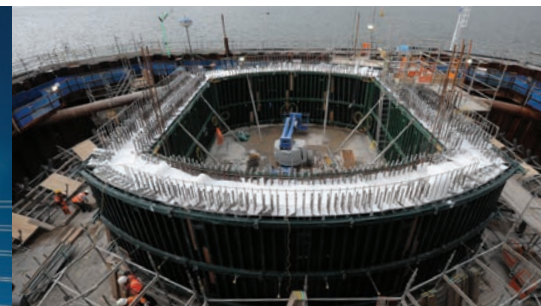

Bartec Plus Type A and Type C Couplers, Queensferry Crossing, UK (Photo courtesy of Transport Scotland)

# Reinforcing Bar Couplers

## MBT

The MBT range of couplers provides a cost-effective method of joining reinforcing bars, particularly when the fixed bar is already in place and there is insufficient space for a hydraulic swaging press.

MBT Couplers are easy to install and achieve failure loads higher than 115% of the characteristic yield strength of grade 500 reinforcing bar. Neither bar end preparation to form threads, nor bar rotation are required. MBT couplers can also be used to join imperial, plain round or deformed reinforcing bars.

The bar ends are supported within the coupler by two serrated saddles, and as the lockshear bolts are tightened, the conical ends embed themselves into the bar. As this happens the serrated saddles bite into both the bar and the shell of the coupler. The lockshear bolts of couplers up to and including the ET20 can be tightened using a ratchet wrench. For larger couplers a nut runner is recommended.

In all cases heavy duty sockets should be used. When the pre-determined tightening torque for the bolts is reached, the heads shear off leaving the top of the installed bolt slightly proud of the coupler. This provides an instant visual check of correct installation.

**Note:** Impact tools must not be used to tighten lockshear bolts.

## MBT ET Series

The MBT ET series of couplers is used to connect reinforcing bars of the same size.

## Testing & Approvals

Full destructive tests are carried out on selected couplers from our stocks. MBT couplers are designed and manufactured in accordance with BS EN ISO 9001. The most common size of ET series couplers are approved to UK CARES TA1-A & TA1-B 5083

and in accordance with the Manual of Contract Documents for Highways Works, Volume 1 Specification for Highways Works, Series 1700 Structural Concrete (Amended March 2020) including the bar sizes featured in the table below. This range also complies with BS 8597: 2015.



Validate with the CARES Cloud App

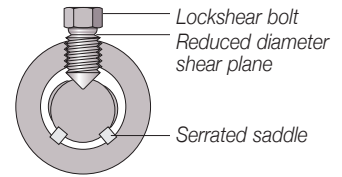

Section showing the embedment of the lockshear bolts and saddles into the bar and the shell of the coupler

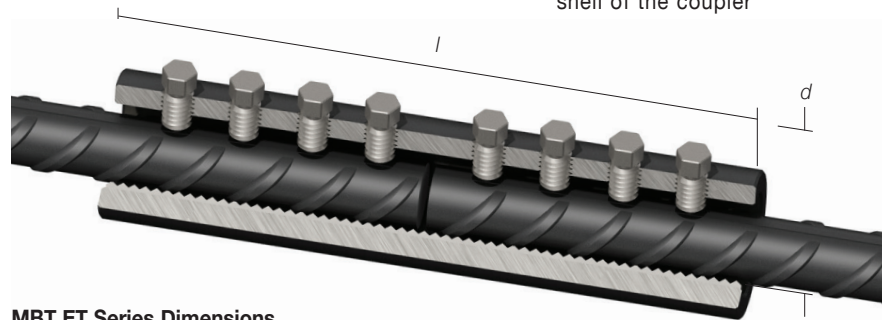

## MBT ET Series Dimensions

Bar Diameter (mm)		12	16	20	25	32	40
External Diameter (mm)	<i>d</i>	33.4	42.2	48.3	54.0	71.0	81.0
Total Length (mm)	<i>l</i>	140	160	204	258	312	484
Socket Size A/F (ins)		1/2	1/2	1/2	5/8	5/8	3/4
No. of Bolts		6	6	8	8	10	14
Approx Weight (kg)		0.72	1.25	1.96	3.00	6.50	11.30
Torque (Nm)		55	108	108	275	360	525
Part No.		ET12	ET16	ET20	ET25	ET32	ET40

**Note:** Other sizes available on request. For details contact us.

## Installation

### MBT ET Series

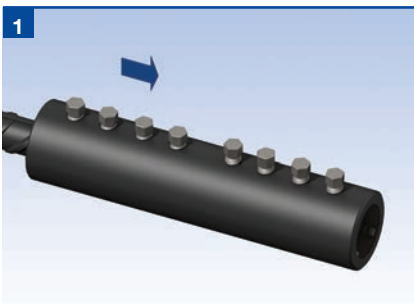

Place the coupler over the end of the bar to half the coupler length +/- 6mm and finger tighten the lockshear bolts onto the bar. Check the alignment and make any necessary adjustments.

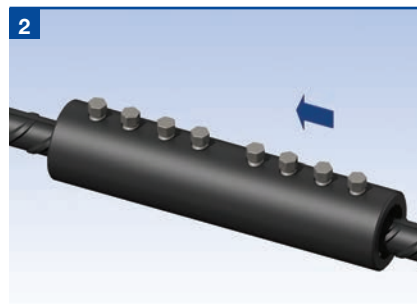

Place the other bar end into the coupler until it pushes up against the first bar and finger tighten the remaining lockshear bolts. Check alignment and make any adjustments.

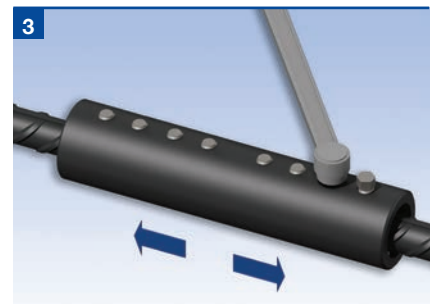

On one half of the coupler, starting from the centre and working outwards, partly tighten the lockshear bolts using either a ratchet wrench or a nut runner as appropriate. Do not use impact tools. Repeat again, this time fully tightening the lockshear bolts until the bolt heads shear off.

Repeat the above for the other half of the coupler.



## MBT Transition Series

The MBT Transition series of couplers provides an effective solution for connecting bars of different diameters.

Transition couplers have all of the benefits of the ET series and are designed to achieve failure loads higher than 115% of the characteristic yield strength of the smaller grade 500 reinforcing bar.

They can be installed without any preparation to the bar ends and without any need to rotate bars.

The coupler can be rotated to allow access to the bolts for tightening with either a ratchet wrench or a nut runner. In all cases heavy duty sockets should be used.

**Note:** Impact tools should not be used to tighten lockshear bolts.

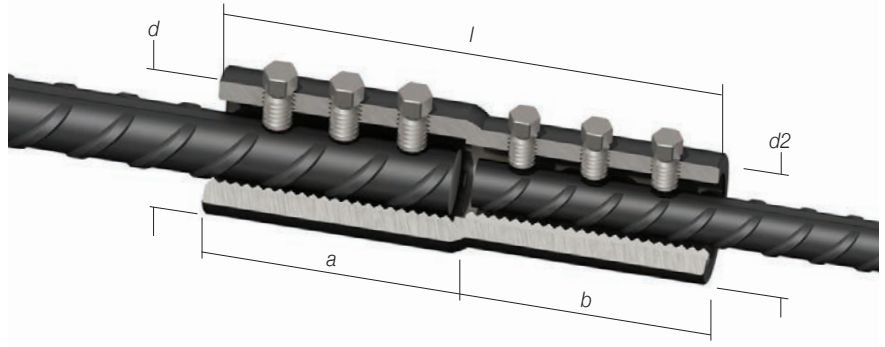

### MBT Transition Series Dimensions

Bar Diameter (mm)		16/12	20/12	20/16	25/16	25/20	32/20	32/25	40/32
External Diameter (mm) $d$		42.2	48.3	48.3	54.0	54.0	71.0	71.0	81.0
External Diameter (mm) $d2$		42.2	33.4	48.3	42.2	54.0	48.3	54.0	71.0
Total Length (mm) $l$		160	150	160	155	180	177	231	335
Individual Lengths (mm) $a:b$		80:80	80:70	80:80	75:80	90:90	75:102	102:129	178:157
Socket Size A/F (ins) $a:b$		1/2:1/2	1/2:1/2	1/2:1/2	5/8:1/2	5/8:1/2	5/8:1/2	5/8:5/8	3/4:5/8
No. of Bolts $a:b$		3:3	3:3	3:3	2:3	3:3	2:4	3:4	5:5
Approx Weight (kg)		1.30	1.13	1.56	1.51	2.23	2.55	3.70	7.47
Torque (Nm)		108:55	108:55	108:108	275:108	275:108	360:108	360:275	525:360
Part No.		ET16/12	ET20/12	ET20/16	ET25/16	ET25/20	ET32/20	ET32/25	ET40/32

### Installation

#### MBT Transition Series

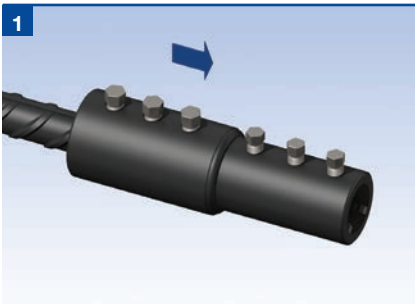

Place the coupler over the end of the bar to the appropriate depth +/- 6mm and finger tighten the lockshear bolts onto the bar. Check the alignment and make any necessary adjustments.

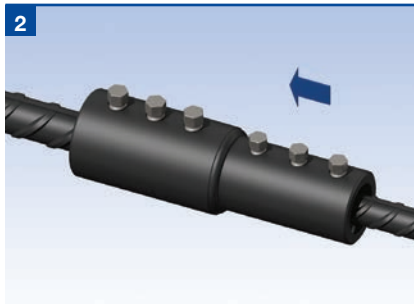

Place the other bar end into the coupler until it pushes up against the first bar and finger tighten the remaining lockshear bolts. Check alignment and make any adjustments.

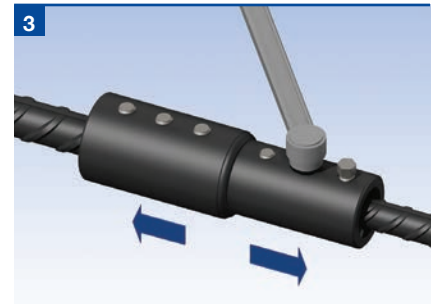

On one half of the coupler, starting from the centre and working outwards, partly tighten the lockshear bolts using either a ratchet wrench or a nut runner as appropriate. Do not use impact tools. Repeat again, this time fully tightening the lockshear bolts until the bolt heads shear off.

Repeat the above for the other half of the coupler.

### Electric Wrench

Ancon Electric Wrenches are available for purchase or hire. The smooth continuous action of the wrench prevents the early shearing of the lockshear bolts and damage to threads. The wrench is supplied with specially hardened heavy duty sockets. For details please contact Leviat.



# Reinforcing Bar Couplers

## MBT Continuity C Series

The MBT Continuity coupler allows reinforcement to be extended at construction joints without the need to drill or otherwise substantially deface the formwork.

The female part of the C Series coupler is fixed to the formwork with the aid of a nail plate.

After removal of the formwork, the nail plate protects the internally threaded end of the coupler. It is advisable to loosen the nail plate to break the bond with the concrete whilst it is still 'green'. When the nail plate is removed, the male section can be screwed into the existing section of the coupler.

Additional locknuts are used to secure the connection.

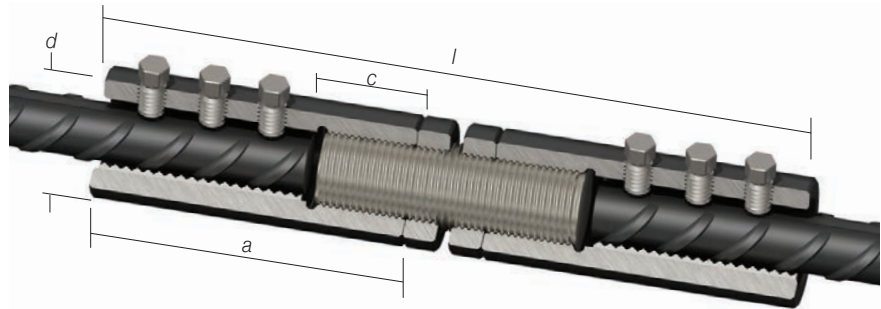

Bar Diameter (mm)		12	16	20	25	32	40
External Diameter (mm)	<i>d</i>	33.4	42.2	48.3	54.0	71.0	81.0
Maximum Length (mm)	<i>l</i>	250	280	349	414	490	675
Female Component Length (mm)	<i>a</i>	100	115	147	177	214	300
Threaded Section (mm)	<i>c</i>	30	35	38	43	53	53
Socket Size A/F (ins)		1/2	1/2	1/2	5/8	5/8	3/4
No. of Bolts		6	6	8	8	10	14
Nail Plate Diameter x Thickness (mm)		75 x 5	75 x 5	75 x 5	100 x 5	100 x 5	127 x 5
Approx Weight (kg)		1.40	2.20	3.70	5.15	11.5	18.8
Torque (Nm)		55	108	108	275	360	525
Part No.		C12	C16	C20	C25	C32	C40

## Installation

### MBT Continuity C Series

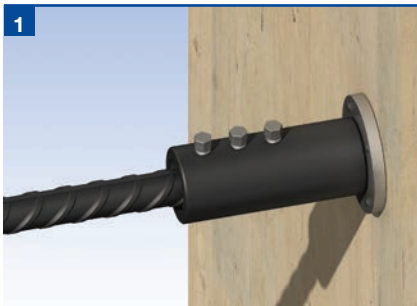

Fix the nail plate to the formwork and fully screw the female component onto the plate. Insert the bar into the coupler, ensuring that it does not encroach into the threaded section. Finger tighten the lockshear bolts. Check alignment and make any adjustments.

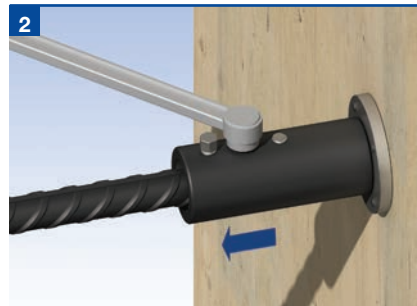

Starting from the nail plate end and working outwards, partly tighten the lockshear bolts using either a ratchet wrench or a nut runner as appropriate. Do not use impact tools. Repeat again, this time fully tightening the lockshear bolts until the bolt heads shear off. Cast in concrete.

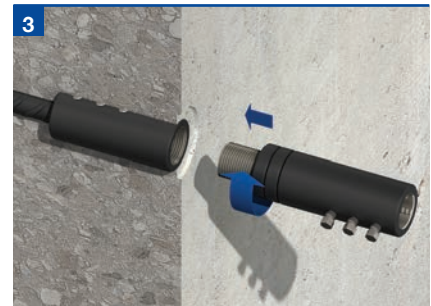

Remove the formwork and unscrew the nail plate. The male component can now be fully screwed into the fixed female component. The male component can be rotated up to a full turn to allow the bolts to be located in an accessible position for tightening.



Run the locknut along the threaded male stud to abut the female component. Fully tighten the locknut against the female section using a wrench.

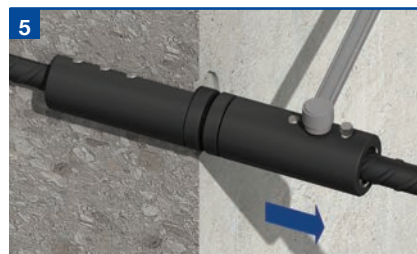

Place the continuation bar into the male component and finger tighten the bolts. Check alignment and make any adjustments. Starting from the centre and working outwards, partly tighten the lockshear bolts using either a ratchet wrench or a nut runner as appropriate. Do not use impact tools. Repeat again, this time fully tightening the lockshear bolts until the bolt heads shear off. Fully tighten the locknut.

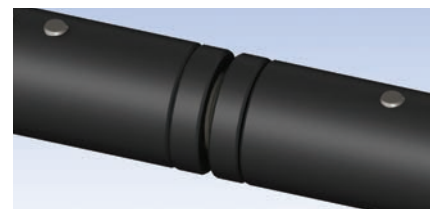

**Note:** When the coupler is fully assembled the visible threaded stud between the two locknuts must not exceed 20mm.

**Note:** The Continuity Coupler male component will be delivered with the threaded stud already in place and the locknuts located on the threaded stud. If the female component is to be left in situ for an extended period, the threads must be greased to prevent corrosion.

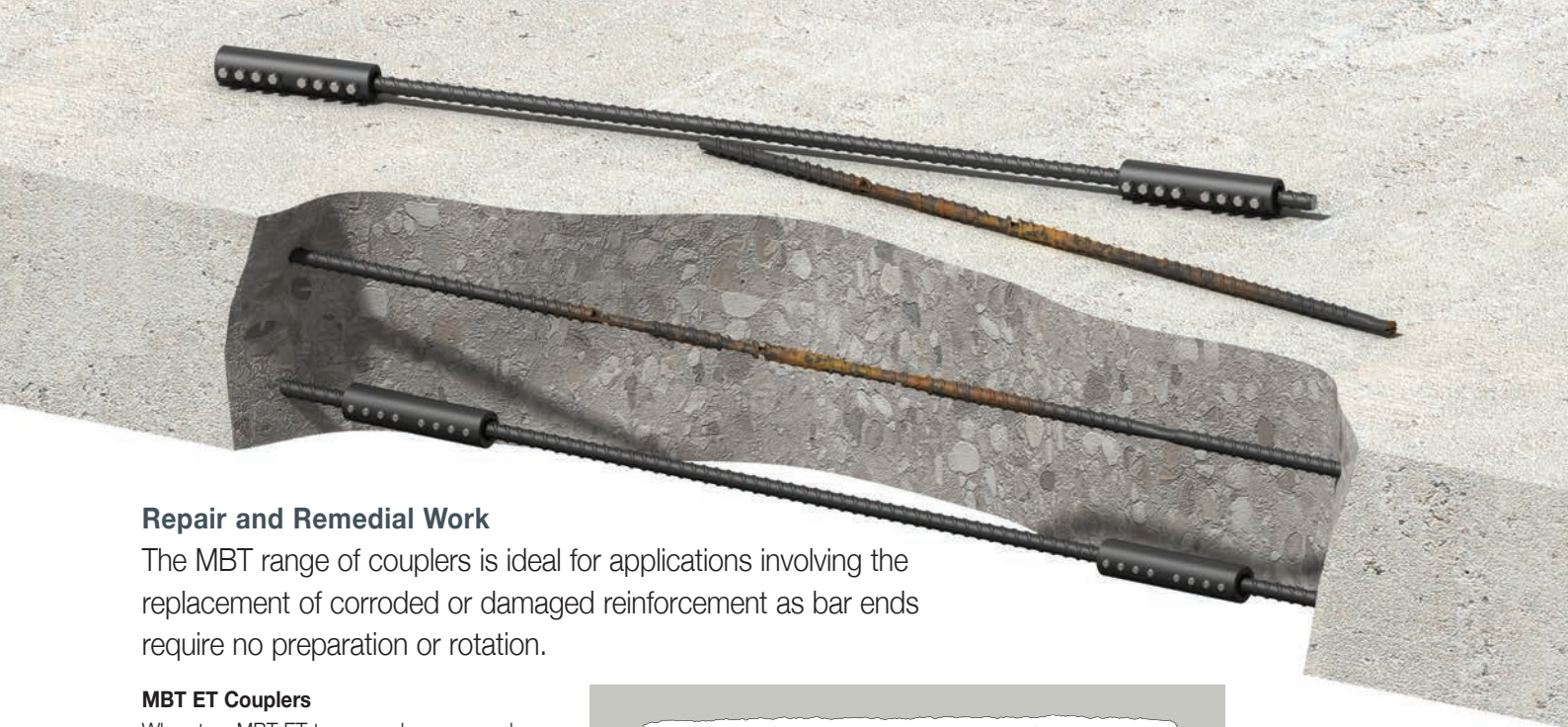

## Repair and Remedial Work

The MBT range of couplers is ideal for applications involving the replacement of corroded or damaged reinforcement as bar ends require no preparation or rotation.

### MBT ET Couplers

When two MBT ET type couplers are used, the replacement bar is cut approximately 5mm shorter than the original length to allow clearance for insertion between the sound ends of the in-situ bars. MBT ET couplers are pushed fully over both ends of the replacement bar and temporarily held in position. The replacement bar is then correctly positioned and the couplers moved to a previously marked position on the existing bars. The lockshear bolts are tightened to complete the installation.

The above application is suitable where the bar being replaced is at least 2 x MBT ET coupler length (see page 22) + 100mm.

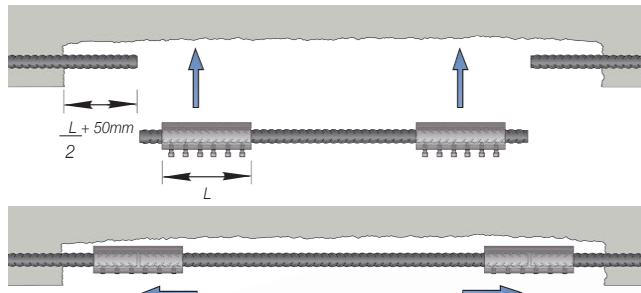

Bar replacement using two MBT ET Couplers

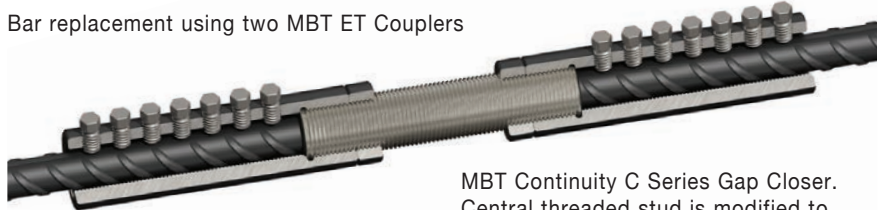

MBT Continuity C Series Gap Closer. Central threaded stud is modified to suit the gap.

### MBT Continuity C Series Gap Closer

A smaller section of bar can be removed and replaced by an MBT Continuity C Series coupler. The central threaded stud can be modified to suit the gap. The table provides the minimum bar length (dimension A) and minimum concrete pocket length (dimension B) to be cut away to facilitate this solution.

### MBT Continuity C Series Gap Closer

Bar Diameter (mm)	Minimum Dimensions	
	A	B
12	100	300
16	115	345
20	147	441
25	177	531
32	214	642
40	300	900

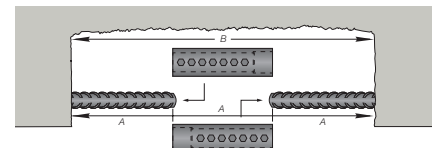

## Installation

### Bar replacement using MBT Continuity C Series Gap Closer



1 Orientate so threaded sections face inwards and pass the two halves of the continuity coupler over the opposing bar ends to leave the gap visible.



2 Insert appropriately sized stud in the gap and rotate each half of the coupler so the stud locates fully in each internal thread.



3 Tighten locknuts against the couplers. Shear bolt heads to complete installation by starting from the centre and working outwards and partly tightening the lockshear bolts using either a ratchet wrench or a nut runner as appropriate. Do not use impact tools. Repeat again, this time fully tightening the lockshear bolts.

# Reinforcing Bar Couplers



## MBT Headed Anchors

MBT Headed Anchors are designed to provide dead end embedment for bars in concrete. This helps to reduce congestion and simplify the placement of rebars by removing the need for hooked ends.

The anchor comprises half an MBT coupler with a plate welded to one end which carries the full tension load of the bar when it is bearing against the concrete. Plates can be supplied with or without a hole, allowing bars to either end in the coupler or pass through. The MBT Headed Anchor also has the added advantage of requiring no special bar end preparation.

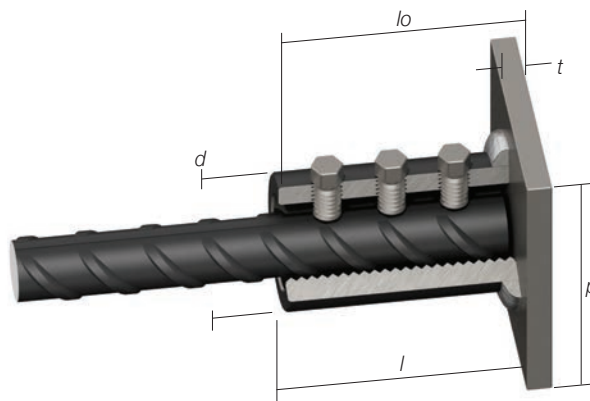

Bar Diameter (mm)		12	16	20	25	32	40
External Diameter (mm)	<i>d</i>	33.4	42.2	48.3	54.0	71.0	81.0
Coupler Length (mm)	<i>l</i>	75	82	104	129	156	247
Total Length (mm)	<i>lo</i>	85	92	114	139	171	262
Plate Thickness (mm)	<i>t</i>	10	10	10	10	15	15
Plate w x h (mm)	<i>p</i>	70	80	90	100	130	150
Socket Size A/F (ins)		1/2	1/2	1/2	5/8	5/8	3/4
No of Bolts		3	3	4	4	5	7
Approx Weight (kg)		0.74	1.07	1.58	2.29	4.72	8.30
Torque (Nm)		55	108	108	275	360	525
Part No. (No hole in plate)		ETHA12	ETHA16	ETHA20	ETHA25	ETHA32	ETHA40
Part No. (Hole in plate)		ETHA12H	ETHA16H	ETHA20H	ETHA25H	ETHA32H	ETHA40H

**Note:** Minimum compressive strength of concrete 25/mm<sup>2</sup>. Other sizes are available on request.



## HM Grout Sleeve Couplers

Ancon HM Grout Sleeves have been designed to cater for the rebar tolerance/bar alignment issues associated with joining precast concrete elements together.

The range comprises two standard coupler types: Full-grout sleeves and Half-grout sleeves. In the first, bars are simply inserted to meet at the nominal centre point of the sleeve. In the latter, one end features a threaded insert to accept a pre-threaded bar while the other end is open to accommodate a non-threaded continuation bar. The standard insert suits Ancon Bartec Plus parallel-threaded rebars. Other inserts are available.



HM Full-grout Coupler



HM Half-grout Coupler

These couplers are machined from seamless high strength steel tube and used with our high performance, shrinkage-compensated, cementitious grout.

Tests show compliance with the rebar coupler performance specifications in BS 8597 and ISO 15835.

Contact us for full technical details or download the product brochure online.

## Other Ancon Products

### Reinforcement Continuity Systems

Reinforcement Continuity Systems are an increasingly popular means of maintaining continuity of reinforcement at construction joints in concrete. The Ancon Eazistrip re-bend system is approved by UK CARES and consists of pre-bent bars housed within a galvanised steel casing. Once installed, the bars are straightened ready for lapping with slab reinforcement. Ancon KSN Anchors and Ancon Starter Bars are cast into a concrete wall and accept threaded continuation bars. They easily accommodate long EC2 lap lengths and eliminate the need for on-site bar straightening. KSN Anchors minimise rebar congestion in the wall.



### Shear Load Connectors

Ancon DSD and ESD Shear Load Connectors are used to transfer shear across expansion and contraction joints in concrete. They are more effective at transferring load and allowing movement to take place than standard dowels. The range features rectangular box section sleeves to allow lateral movement in addition to longitudinal movement. A range of Lockable Dowels is available for temporary movement joints in post-tensioned concrete.



### Channel and Bolt Fixings

We offer a wide range of channels and bolts in order to fix stainless steel masonry support, restraints and windposts to structural frames. Cast-in channels and expansion bolts are used for fixing to the edges of concrete floors and beams.



### Punching Shear Reinforcement

Ancon Shearfix is used within a slab to provide additional reinforcement from punching shear around columns. The system is approved by UK CARES and consists of double-headed steel studs welded to flat rails. Shearfix is designed to suit the load conditions and slab depth at each column using free calculation software from us.



### Insulated Balcony Connections

Ancon thermally insulated connectors minimise heat loss at balcony locations while maintaining structural integrity. They provide a thermal break and, as a critical structural component, transfer moment, shear, tension and compression forces. Standard solutions are available for concrete-to-concrete, steel-to-concrete and steel-to-steel interfaces.





**Leviat<sup>®</sup>**  
A CRH COMPANY

Innovative engineered products and construction solutions that allow the industry to build safer, stronger and faster.



## Worldwide contacts for Leviat:

### Australia

**Leviat**  
98 Kurrajong Avenue,  
Mount Druitt Sydney, NSW 2770  
Tel: +61 - 2 8808 3100  
Email: info.au@leviat.com

### Austria

**Leviat**  
Leonard-Bernstein-Str. 10  
Saturn Tower, 1220 Wien  
Tel: +43 - 1 - 259 6770  
Email: info.at@leviat.com

### Belgium

**Leviat**  
Industrielaan 2  
1740 Ternat  
Tel: +32 - 2 - 582 29 45  
Email: info.be@leviat.com

### China

**Leviat**  
Room 601 Tower D, Vantone Centre  
No. A6 Chao Yang Men Wai Street  
Chaoyang District  
Beijing · P.R. China 100020  
Tel: +86 - 10 5907 3200  
Email: info.cn@leviat.com

### Czech Republic

**Leviat**  
Business Center Šafránková  
Šafránková 1238/1  
155 00 Praha 5  
Tel: +420 - 311 - 690 060  
Email: info.cz@leviat.com

### Finland

**Leviat**  
Vädursgatan 5  
412 50 Göteborg / Sweden  
Tel: +358 (0)10 6338781  
Email: info.fi@leviat.com

### France

**Leviat**  
6, Rue de Cabanis  
FR 31240 L'Union  
Toulouse  
Tel: +33 - 5 - 34 25 54 82  
Email: info.fr@leviat.com

### Germany

**Leviat**  
Liebigstrasse 14  
40764 Langenfeld  
Tel: +49 - 2173 - 970 - 0  
Email: info.de@leviat.com

### India

**Leviat**  
309, 3rd Floor, Orion Business Park  
Ghodbunder Road, Kapurbawdi,  
Thane West, Thane,  
Maharashtra 400607  
Tel: +91 - 22 2589 2032  
Email: info.in@leviat.com

### Italy

**Leviat**  
Via F.lli Bronzetti 28  
24124 Bergamo  
Tel: +39 - 035 - 0760711  
Email: info.it@leviat.com

### Malaysia

**Leviat**  
28 Jalan Anggerik Mokara 31/59  
Kota Kemuning, 40460 Shah Alam  
Selangor  
Tel: +603 - 5122 4182  
Email: info.my@leviat.com

### Netherlands

**Leviat**  
Oostermaat 3  
7623 CS Borne  
Tel: +31 - 74 - 267 14 49  
Email: info.nl@leviat.com

### New Zealand

**Leviat**  
2/19 Nuttall Drive, Hillsborough,  
Christchurch 8022  
Tel: +64 - 3 376 5205  
Email: info.nz@leviat.com

### Norway

**Leviat**  
Vestre Svanholmen 5  
4313 Sandnes  
Tel: +47 - 51 82 34 00  
Email: info.no@leviat.com

### Philippines

**Leviat**  
2933 Regus, Joy Nostalg,  
ADB Avenue  
Ortigas Center  
Pasig City  
Tel: +63 - 2 7957 6381  
Email: info.ph@leviat.com

### Poland

**Leviat**  
Ul. Obornicka 287  
60-691 Poznań  
Tel: +48 - 61 - 622 14 14  
Email: info.pl@leviat.com

### Singapore

**Leviat**  
14 Benoi Crescent  
Singapore 629977  
Tel: +65 - 6266 6802  
Email: info.sg@leviat.com

### Spain

**Leviat**  
Poligono Industrial Santa Ana  
c/ Ignacio Zuloaga, 20  
28522 Rivas-Vaciamadrid  
Tel: +34 - 91 632 18 40  
Email: info.es@leviat.com

### Sweden

**Leviat**  
Vädursgatan 5  
412 50 Göteborg  
Tel: +46 - 31 - 98 58 00  
Email: info.se@leviat.com

### Switzerland

**Leviat**  
Grenzstrasse 24  
3250 Lyss  
Tel: +41 - 31 750 3030  
Email: info.ch@leviat.com

### United Arab Emirates

**Leviat**  
RA08 TB02, PO Box 17225  
JAFZA, Jebel Ali, Dubai  
Tel: +971 (0)4 883 4346  
Email: info.ae@leviat.com

### United Kingdom

**Leviat**  
President Way, President Park,  
Sheffield, S4 7UR  
Tel: +44 - 114 275 5224  
Email: info.uk@leviat.com

### United States of America

**Leviat**  
6467 S Falkenburg Rd.  
Riverview, FL 33578  
Tel: (800) 423-9140  
Email: info.us@leviat.us

### For countries not listed

Email: info@leviat.com

**Leviat.com**

#### Notes regarding this catalogue

© Protected by copyright. The construction applications and details provided in this publication are indicative only. In every case, project working details should be entrusted to appropriately qualified and experienced persons. Whilst every care has been exercised in the preparation of this publication to ensure that any advice, recommendations or information is accurate, no liability or responsibility of any kind is accepted by Leviat for inaccuracies or printing errors. Technical and design changes are reserved. With a policy of continuous product development, Leviat reserves the right to modify product design and specification at any time.



For more information on these products, contact:

**Leviat**

President Way  
President Park  
Sheffield, S4 7UR  
United Kingdom

Tel: +44 (0) 114 275 5224  
Fax: +44 (0) 114 276 8543

Email: [info.ancon.uk@leviat.com](mailto:info.ancon.uk@leviat.com)

For sales and technical enquiries:  
Email: [reinforcement.uk@leviat.com](mailto:reinforcement.uk@leviat.com)

[Ancon.co.uk](http://Ancon.co.uk)  
[Leviat.com](http://Leviat.com)