

# Masonry Support Systems & Lintels

**Ancon**  
Optima®

Standard AnconOptima 14 System.  
Standard Brackets, Locking Wedges and  
a 790mm Angle with Blue Fixing Zones

Patent No. EP 1211364



## Standard Systems

Standard systems, referenced AnconOptima 10, 12 and 14, support a masonry load of up to 10kN, 12kN and 14kN per metre respectively. All components are available from stock.

Brackets are available to suit cavities from 60mm to 150mm and are stocked in 5mm increments. Depending on the fixing type, brackets can be changed on site for one of a different depth to allow for cavity variations. Two brackets of a different depth can be used on the same angle.

The brackets used across the three standard systems are universal. The differing performance of the three systems is generated by the varying length and thickness of the angle and the fixing centres of the brackets.

Standard left-hand and right-hand corners are available.

Not being specific to a particular project, unused components can be moved to another project or, for a small restocking charge, returned to Ancon.

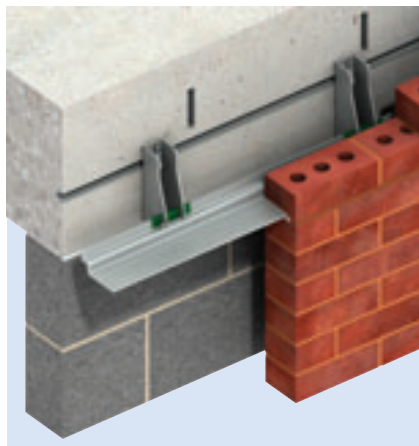

AnconOptima 12 System

Standard AnconOptima systems are specified from the simple load/cavity charts shown on page 11. Please note the fixing type may affect the maximum masonry load of the system specified.

## Non-Standard Systems

AnconOptima was conceived by Ancon's technical staff primarily as a standard solution for loads up to 14kN/m, however it can be designed to suit other applications. Although the components of a non-standard AnconOptima system are not available from stock and cannot be returned to Ancon for restocking, they still provide greater flexibility in the fixing position and are less cumbersome to handle on site than a comparable welded bracket system.

Typical applications of a non-standard AnconOptima system are loads up to 20kN/m or where a different angle position on the bracket is needed e.g. projecting angle.

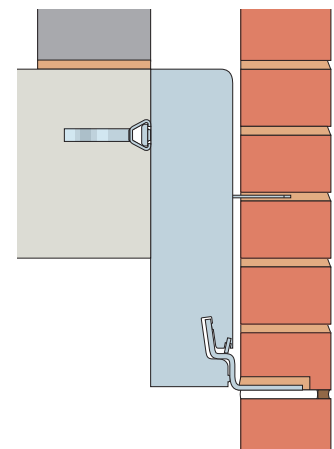

Bespoke AnconOptima/P Support System



### Cavity Variations

The ability of welded bracket support systems to accommodate variations in the line of the structure is limited by the maximum thickness of shims, normally 12mm. Some additional adjustment will be possible by varying the bearing of the brickwork on the support angle but this will be very limited, particularly where pistol bricks are used.

When using a standard AnconOptima system, brackets are available from stock to suit cavities from 60mm to 150mm in 5mm increments. They can be changed on site to allow for variations in the edge beam. Shims can be used for fine adjustments and should never need to be more than 4mm thick.

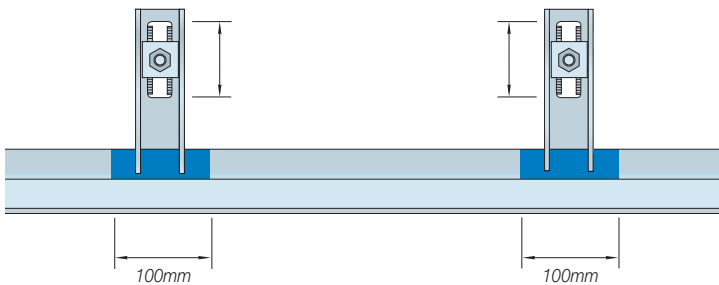

Adjustment of AnconOptima

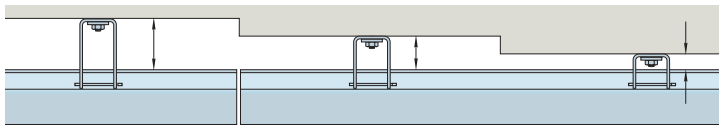

AnconOptima accommodates variations in the line of the edge beam. Brackets of a different depth can be used on the same angle

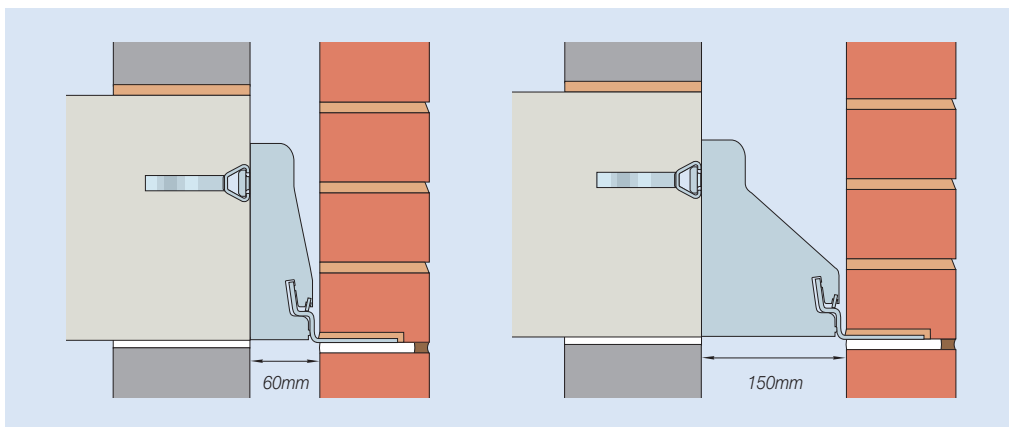

Standard brackets are available to suit cavities from 60mm to 150mm

### Vertical Adjustment

Vertical adjustment is achieved by the deep slot in the back of the bracket.

### Horizontal Adjustment

AnconOptima angles have a 100mm pre-marked fixing zone which provides 50mm horizontal adjustment.

If fixing into concrete with expansion bolts, the bracket can be moved to eliminate clashes between the bolts and reinforcing bars.

Horizontal adjustment can be increased by fixing the system to an Ancon channel cast into the face of the concrete.

If fixing to steelwork, the brackets can be moved to align with the location of a hole, negating the need for a more expensive horizontal slot to be provided.

### Benefits of Standard Systems

- More adjustable than welded bracket systems
- Specified by using simple load/cavity charts
- No requirement for detailed layout drawings
- Supplied from stock
- Faster to install
- Easier to move around site
- Unused items can be used on the next project or restocked

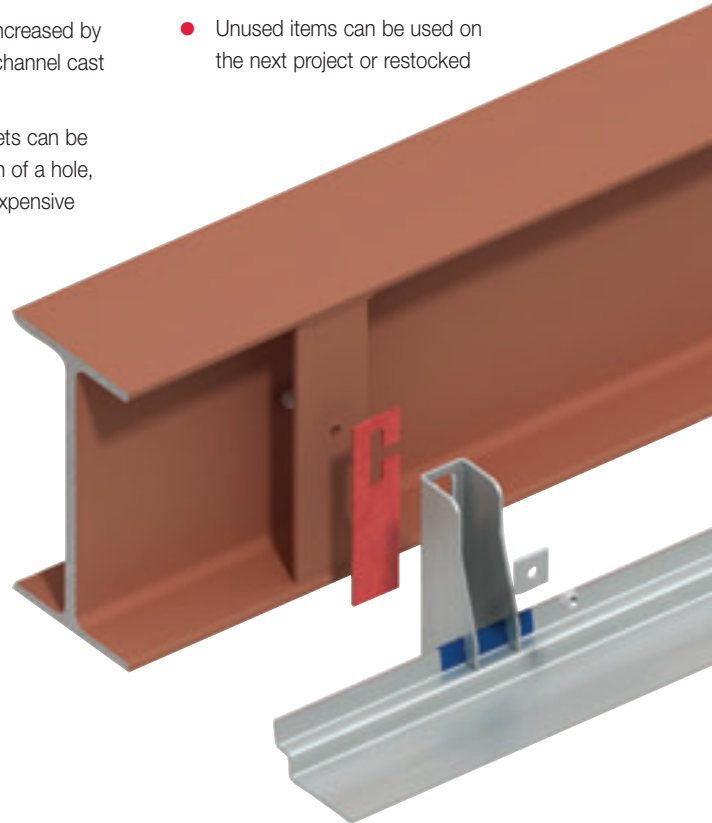

AnconOptima fixed through hole, rather than slot, in steelwork. Adjustment provided by fixing zone on angle. Shown with Ancon Thermal Break which also isolates the dissimilar metals.

# Masonry Support Systems & Lintels



## Setting Out of Standard Systems

Unlike bespoke systems, there is no time-consuming setting out of individually referenced components with a standard system to a detailed layout drawing.

## Cutting on site

Standard AnconOptima systems are not designed for specific buildings and certain angles will need to be cut on site to suit the length required. Each angle section must have at least two brackets.

## Corners

Standard left-hand and right-hand corners are available. Each corner section requires three brackets in order to achieve the required performance. These sections should never be cut.

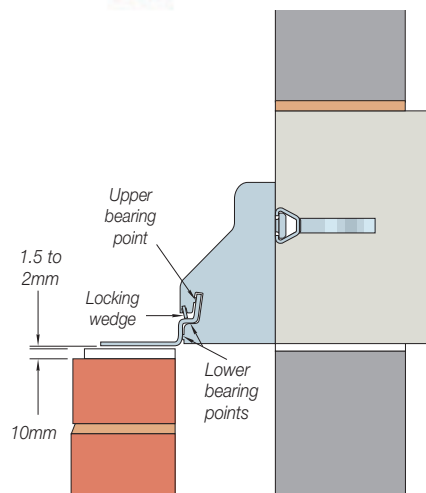

Correct installation of AnconOptima

## Installation

Installation of AnconOptima provides significant time savings over welded support systems. The individual components are easier to move around site, often without hiring crane time. The preferred technique of installers is to level and fix two brackets and simply slide the angle into position. This reduces the time spent tightening and loosening the fixing bolts of a welded bracket system, in order to achieve a level horizontal shelf. Where space limitations prevent the angle from sliding, the brackets can be positioned on the angle and conventionally fixed; the smaller lengths of angle simplify this method of installation. When the brackets and angle are in position a locking wedge is tapped with a hammer through the notches in each bracket. These wedges ensure the correct contact is achieved between angle and brackets. A detailed installation guide is available from Ancon.

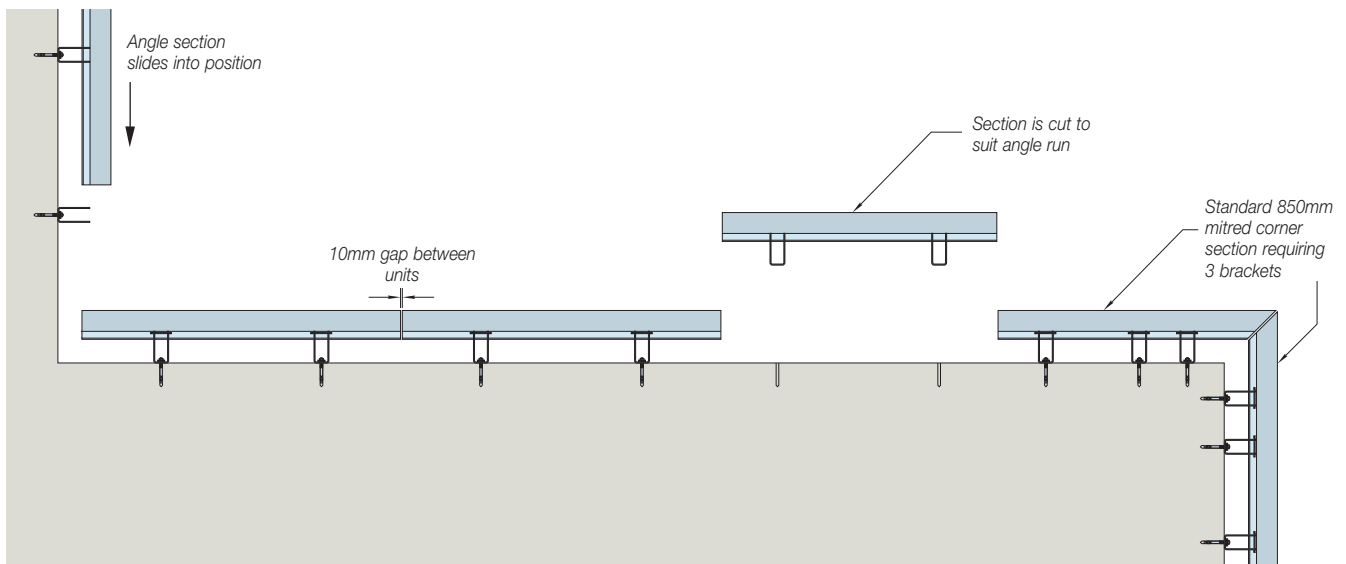

Typical AnconOptima layout

### Details for Specifying and Ordering

Standard AnconOptima Systems simplify the total supply process. They consist of standard components, all available from stock, and can be specified by using the simple load/cavity charts below. Specification does not involve the completion of detailed layout drawings and not being specific to any project, excess items from one site can be used elsewhere.

### Standard Brackets

AnconOptima brackets are readily available from stock to suit cavities from 60mm to 150mm in 5mm increments. Brackets for wider cavities are available on request. A locking wedge is supplied with each bracket to ensure the correct contact is achieved between angle and bracket.

### Standard System Specification Clause

Delete items shown in *italic* as applicable.

AnconOptima 10/12/14 standard masonry support system comprising a 'W' profile stainless steel angle complete with slide on, interchangeable fixing brackets to suit varying cavity width, and locking wedges.

Fix back to *concrete/steelwork* using *expansion bolts/cast-in channel/stainless steel set screws/Steelgrip™*.

System to be installed in accordance with Ancon's instructions.

Manufactured in Grade 1.4301 (304) Austenitic Stainless Steel.

### Advisory Note

These load/cavity tables are designed to provide guidance only. The suitability of any AnconOptima system should be confirmed with Ancon's Technical Services Team. Edge distances, in particular, are critical to performance.

### HIGHER LOAD SYSTEMS AND BRACKET VARIATIONS

Contact Ancon for applications outside the parameters in the tables. Although designed primarily as a standard solution for loads up to 14kN/m, AnconOptima components can be supplied to suit loads up to 20kN/m and be manufactured with a different angle position on the bracket.

### Standard AnconOptima Systems

System	Maximum Load (kN/m)	Angle Length (mm)	Nominal Length (mm) <small>(including 10mm gap between angles)</small>	Fixing Zone Colour	Bracket Position (mm)
AnconOptima 10	10	990	1000	Red	500 centres
AnconOptima 12	12	990	1000	Green	500 centres
AnconOptima 14	14	790	800	Blue	400 centres

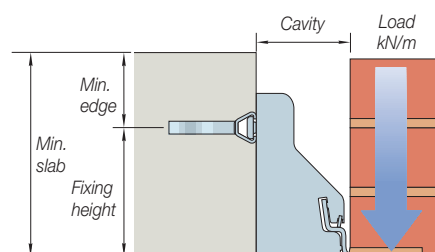

### AnconOptima 10

Fixing	Fixing height (mm)	Min. edge (mm)	Min. slab (mm)	Maximum load (kN/m) for various cavity widths (mm)																				
				60	65	70	75	80	85	90	95	100	105	110	115	120	125	130	135	140	145	150		
30/20 channel	140	75	215	10	10	10	10	10	10	10	10	10	10	10	10	10	9.8	9.6	9.4	9.2	9.0	8.9	8.7	8.5
FAZII 12/30 A4*	140	75	215	10	10	10	10	10	10	10	10	10	10	10	10	10	10	10	10	10	10	10	10	10
FBNII 12/30 A4**	140	90	230	10	10	10	10	10	10	10	10	10	10	10	10	10	10	10	10	10	10	10	9.8	
M12 set screw	140	-	-	10	10	10	10	10	10	10	10	10	10	10	10	10	10	10	10	10	10	10	10	10
M12 Steelgrip™	140	-	-	10	10	10	10	10	10	10	10	10	10	10	10	10	10	10	10	10	10	10	10	10

### AnconOptima 12

Fixing	Fixing height (mm)	Min. edge (mm)	Min. slab (mm)	Maximum load (kN/m) for various cavity widths (mm)																			
				60	65	70	75	80	85	90	95	100	105	110	115	120	125	130	135	140	145	150	
30/20 channel	140	75	215	10.1	12	11.8	11.6	11.4	11.1	10.9	10.7	10.4	10.2	10.0	9.8	9.6	9.4	9.2	9.0	8.9	8.7	8.5	
FAZII 12/30 A4*	140	75	215	10.1	12	12	12	12	12	12	12	12	12	12	12	12	12	12	12	12	11.8	11.6	11.4
FBNII 12/30 A4**	140	105	245	10.1	12	12	12	12	12	12	12	12	12	12	12	12	12	12	12	12	11.8	11.6	11.4
M12 set screw	140	-	-	10.1	12	12	12	12	12	12	12	12	12	12	12	12	12	12	12	12	12	12	12
M12 Steelgrip™	140	-	-	10.1	12	12	12	12	12	12	12	12	12	12	12	12	12	12	12	12	12	12	12

### AnconOptima 14

Fixing	Fixing height (mm)	Min. edge (mm)	Min. slab (mm)	Maximum load (kN/m) for various cavity widths (mm)																			
				60	65	70	75	80	85	90	95	100	105	110	115	120	125	130	135	140	145	150	
30/20 channel	140	75	215	12.7	14	14	14	14	13.9	13.6	13.3	13.1	12.8	12.5	12.3	12.0	11.8	11.5	11.3	11.0	10.9	10.7	
FAZII 12/30 A4*	140	75	215	12.7	14	14	14	14	14	14	14	14	14	14	14	14	14	14	14	14	14	14	14
FBNII 12/30 A4**	140	105	245	12.7	14	14	14	14	14	14	14	14	14	14	14	14	14	14	14	14	14	14	14
M12 set screw	140	-	-	12.7	14	14	14	14	14	14	14	14	14	14	14	14	14	14	14	14	14	14	14
M12 Steelgrip™	140	-	-	12.7	14	14	14	14	14	14	14	14	14	14	14	14	14	14	14	14	14	14	14

**Notes to above tables:** Minimum slab thickness assumes the support angle is level with the bottom of the slab. A thicker slab will be required where this is not the case. \*FAZII 12/30 A4 is an Ancon High Performance Bolt. \*\*FBNII 12/30 A4 is an Ancon Single Expansion Bolt. See page 34 and the Ancon Channel & Bolt Fixings literature for these and other bolts.