

Shot-firing! Knock it on the head

with the new **HAMMER-ON** Fixing

Part of Ancon's innovative
Non-Drill fixing range

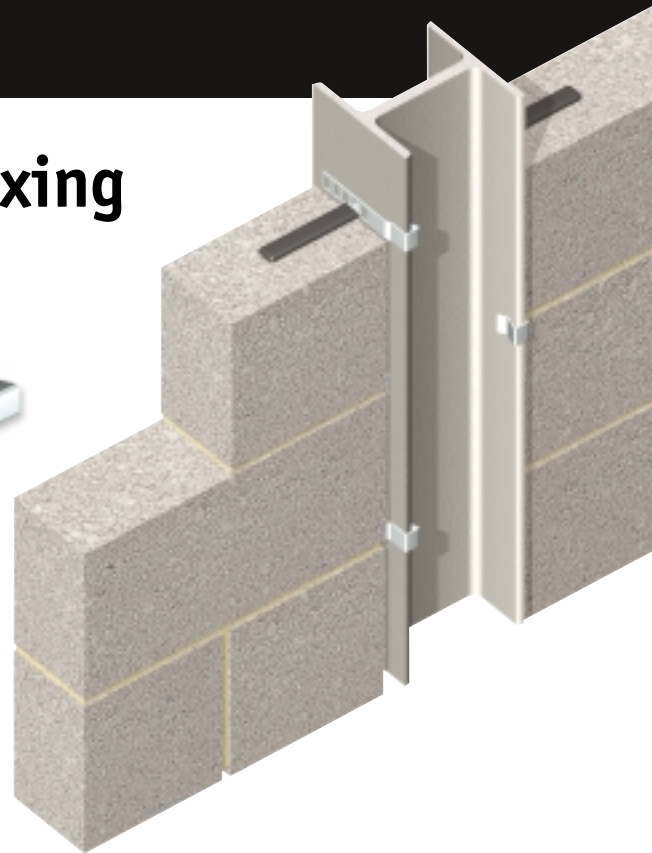
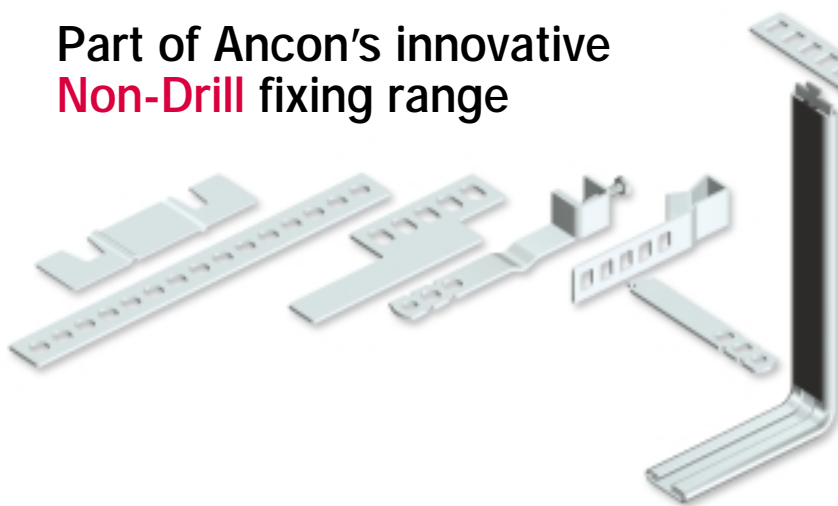

Solutions for all masonry
to steel column applications

Ancon[®]
BUILDING PRODUCTS

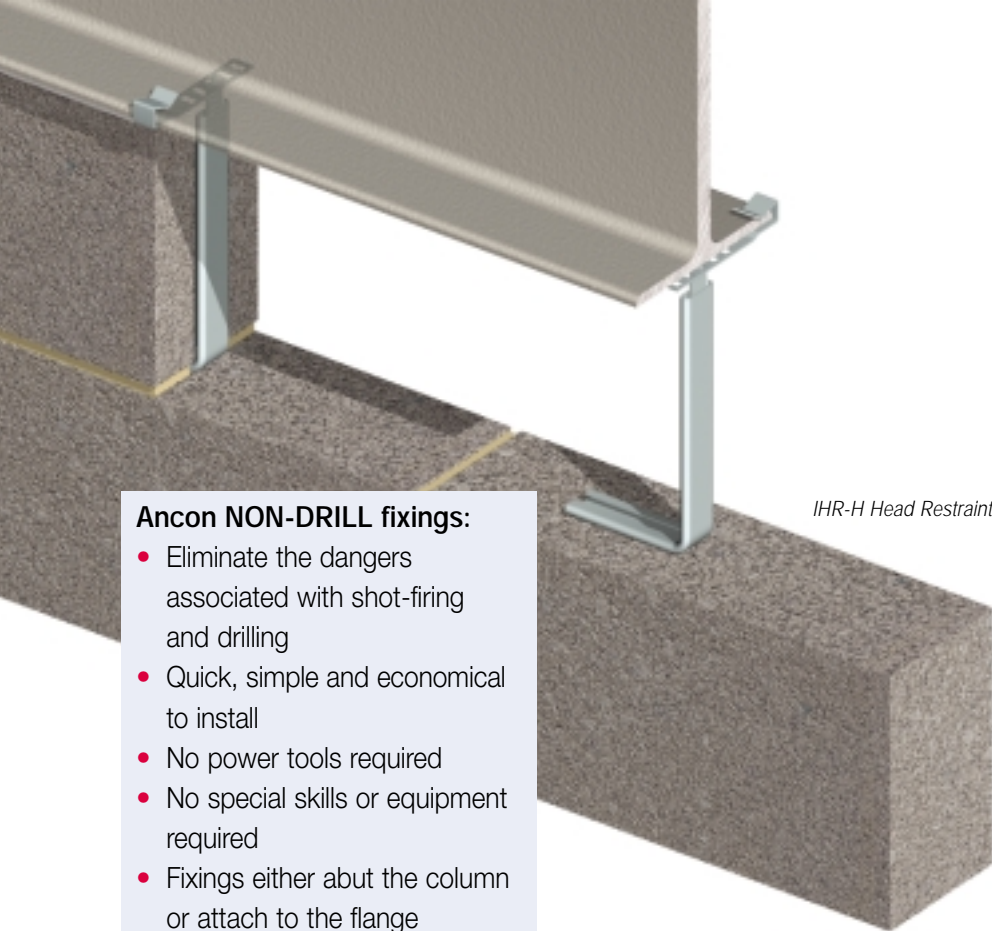

IHR-H Head Restraint

Ancon's range of 'NON-DRILL' masonry-to-steel fixing solutions was developed to address the safety concerns of the Industry.

Driven by customer demand for masonry restraint fixings with an alternate installation method from either shot-firing or drilling, Ancon engineered the six innovative solutions detailed here. These new fixings do not require the use of power tools and can reduce installation times and costs. In all instances they simply abut the column or attach to the flange to restrain the wall against lateral wind loads.

- Ancon NON-DRILL fixings:**
- Eliminate the dangers associated with shot-firing and drilling
 - Quick, simple and economical to install
 - No power tools required
 - No special skills or equipment required
 - Fixings either abut the column or attach to the flange

Hammer-On Fixing

Available in five sizes to accommodate a steel thickness from 7mm to 25mm, this fixing is simply hammered onto the flange. It can be utilised either on a column with a tie or on a beam with an internal head restraint.

The Hammer-On Fixing resists load in one direction only and should be installed on alternate sides of the flange. Ties should be installed at 225mm vertical centres and head restraints at 450mm horizontal centres.

The wall tie (PPH) or head restraint (IHR-H) should be positioned central to the masonry leaf when located in one of the five fixing slots.

Hammer-On Section Ref	Flange Thickness Accommodated
XS	7-10mm
S	10-13mm
M	14-17mm
L	18-21mm
XL	22-25mm

Ancon's new NON-DRILL range has been welcomed by the Industry:

“In recent years we have noticed an increase in the density of steel used on major projects. The difficulties of fixing traditionally with shot fire guns and self-tapping screws slowed down production and also raised the issue of potential incidents.

We have used Ancon's non-drill ties on various projects and have experienced dramatically reduced fixing times and added savings on the use of drills, secondary fixings and extension leads. Another benefit is that there is no restrictions placed on the amount of time an operative can fix ties during the working day.

Potential trip hazards are also reduced as extension leads are not needed; the work area becomes safer.”

Gerry Anderson, Construction Director, Irvine Whitlock Ltd

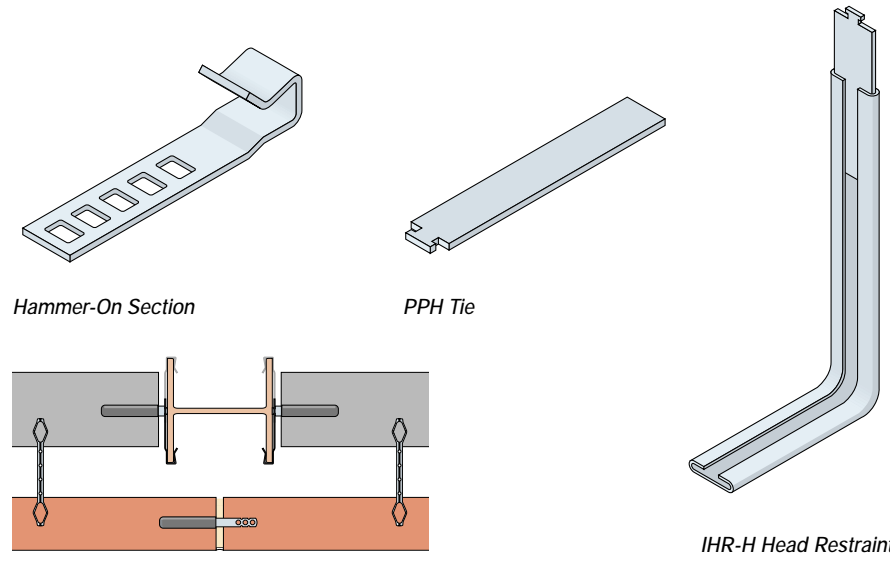

Hammer-On Section

PPH Tie

IHR-H Head Restraint

Other Non-Drill Fixings

Internal Column Tie

Available in seven sizes, this tie fits between the flanges of a column and should be installed at 225mm vertical centres.

Length (mm)	Beam/Column Accommodated
179	203 x 203 UC
186	203 x 133 UB
224	254 x 254 UC
232	254 x 146 UB
275	305 x 305 UC
281	305 x 127 & 165 UB
330	356 x 127 & 171 UB

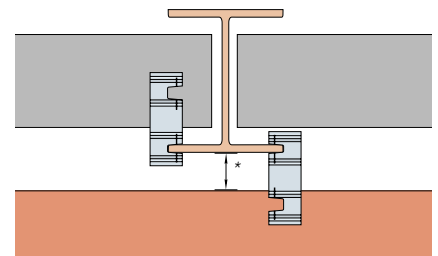
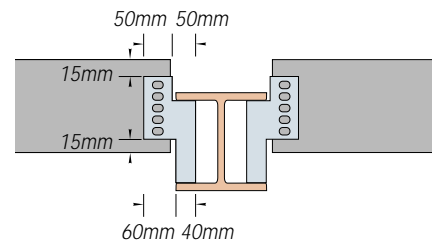
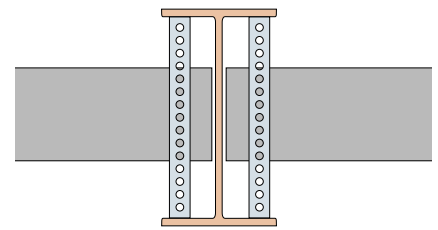
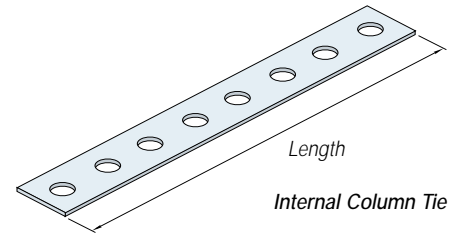

Non-Standard Internal Column Tie

Special internal column ties can be designed to suit applications where the masonry does not sit inside the flanges of a column. The drawing provides some guidance on dimensions; contact Ancon for more information.

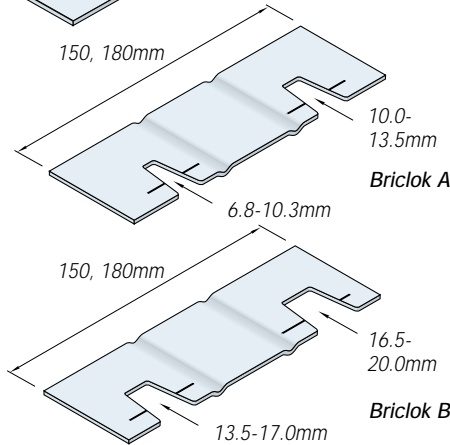
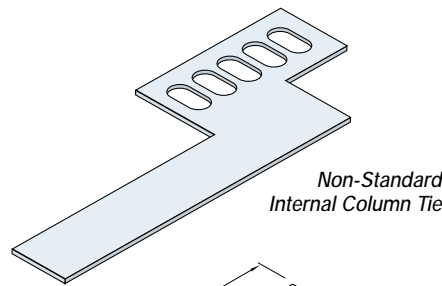

New Briclok

The Briclok fits to a column flange and can be used either across a cavity or back into the inner leaf. It should be positioned with the appropriate notch around the flange and installed at 225mm vertical centres. The tie must not be forced onto the column and should have no less than 10mm engagement. Two types (A and B) accommodate a steel thickness from 6.8mm to 20mm and are available in two lengths to suit an open cavity from 20mm to 80mm.

Product Code	Length	Open Cavity*	Flange Thickness
Briclok150A	150mm	20-50mm	6.8-13.5mm
Briclok180A	180mm	50-80mm	6.8-13.5mm
Briclok150B	150mm	20-50mm	13.5-20.0mm
Briclok180B	180mm	50-80mm	13.5-20.0mm

* Open cavity at column face.

Column Tie

The Column Tie clamps to the flange of a column. It accommodates a steel thickness from 6mm to 25mm and should be installed at 225mm vertical centres. Manufactured in lengths to suit the application, it can feature a drip for use across the cavity or a plain shank for installation back into the inner leaf.

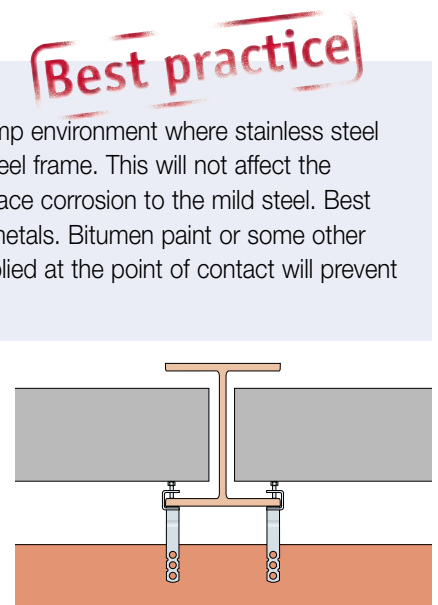
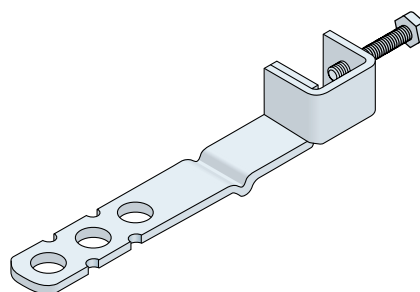

Avoiding Bi-Metallic Corrosion

Best practice

Bi-metallic corrosion may occur in a damp environment where stainless steel fixings are in contact with a structural steel frame. This will not affect the stainless steel but may cause slight surface corrosion to the mild steel. Best practice is to isolate the two dissimilar metals. Bitumen paint or some other form of isolation e.g. adhesive tape, applied at the point of contact will prevent this corrosion.

Column Tie

Ancon Building Products

President Way, President Park
Sheffield S4 7UR
United Kingdom
Tel: +44 (0) 114 275 5224
Fax: +44 (0) 114 276 8543
Email: info@ancon.co.uk
Visit: www.ancon.co.uk

Ancon (Middle East) FZE

PO Box 17225
Jebel Ali
Dubai
United Arab Emirates
Tel: +971 (0) 4 883 4346
Fax: +971 (0) 4 883 4347
Email: anconcl@emirates.net.ae

Ancon Building Products

114 Kurrajong Avenue
Mount Druitt
Sydney
NSW 2770
Australia
Tel: +61 (0) 2 9675 1000
Fax: +61 (0) 2 9675 3390
Email: pac.ancon@anconbp.com.au
Visit: www.anconbp.com.au

Ancon (Schweiz) AG

Gewerbezone Widalmi 10
3216 Ried bei Kerzers
Switzerland
Tel: +41 (0) 31 750 3030
Fax: +41 (0) 31 750 3033
Email: info@ancon.ch
Visit: www.ancon.ch

Ancon Building Products GesmbH

Gerspergasse 9/3 Top 1
A-1210 Vienna
Austria
Tel: +43 (0) 1 259 58 62-0
Fax: +43 (0) 1 259 58 62-40
Email: info@ancon.at
Visit: www.ancon.at

Ancon GmbH

Bartholomäusstrasse 26
90489 Nuremberg
Germany
Tel: +49 (0) 911 955 1234 0
Fax: +49 (0) 911 955 1234 9
Email: info@anconbp.de
Visit: www.anconbp.de

These products are available from:

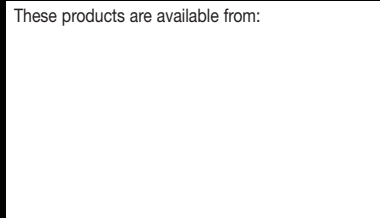

© Ancon Building Products 2006

The construction applications and details provided in this literature are indicative only. In every case, project working details should be entrusted to appropriately qualified and experienced persons.

Whilst every care has been exercised in the preparation of this document to ensure that any advice, recommendations or information is accurate, no liability or responsibility of any kind is accepted in respect of Ancon Building Products.

With a policy of continuous product development Ancon Building Products reserves the right to modify product design and specification without due notice.



BS EN ISO 9001 : 2000
FM12226

Hammer-On Tie and Head Restraint - Design Sheet

FAO: Sales Department

To enable Ancon to supply the most appropriate fixing for your application please complete the necessary details below and fax back to +44 (0) 114 276 8543.



1. Hammer-On Column Tie

Components

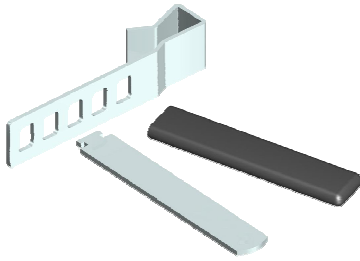

Your Application

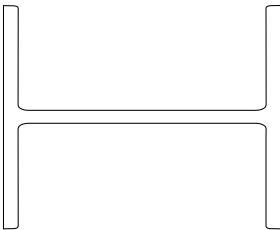

a = _____ mm
b = _____ mm
c = _____ mm
d1 = _____ mm
d2 = _____ mm

Example Application in Plan View

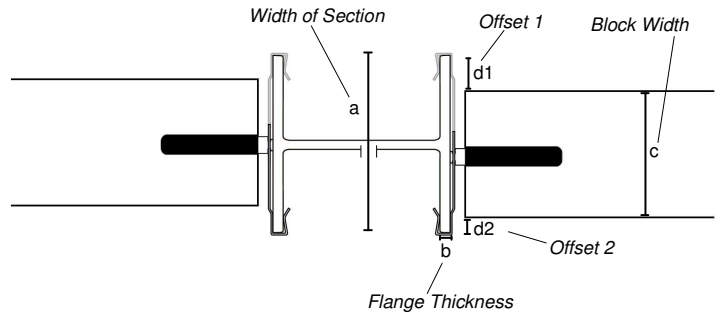

Performance data: Ancon Hammer-On ties have an individual declared shear capacity of 2.7kN; when fixed at 225mm vertical centres, staggered on alternate sides of the column flange (effective centres 450mm on each side) the shear capacity per metre will be 6kN in either direction.

Quantity required _____ No.

2. Hammer-On Head Restraint (IHR-H)

Components



Your Application

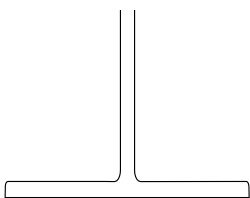

a = _____ mm
b = _____ mm
c = _____ mm
d1 = _____ mm
d2 = _____ mm

Example Application in Vertical Section View

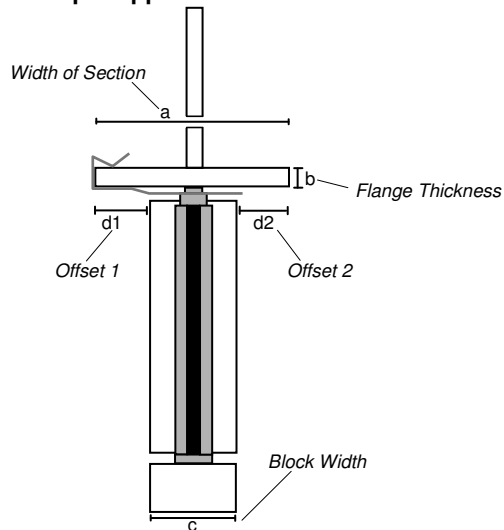

3. Your Details

Contact: _____

Company Name: _____

Address: _____

Tel: _____

Fax: _____

Quotation Tick boxes as appropriate

Order Delivery to above address

Quantity required _____ No.

Fax Back to: +44 (0) 114 276 8543

Ancon Building Products, President Way, President Park, Sheffield, S4 7UR Tel: +44 (0) 114 275 5224 Email: info@ancon.co.uk

Internal Column Ties - Design Sheet

Date: _____

FAO: Sales Department

To enable Ancon to supply the most appropriate fixing for your application please complete the necessary details below and fax back to +44 (0) 114 276 8543.



1. Internal Column Tie

Used when blockwork sits within column

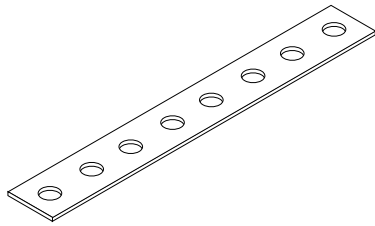

Standard Sizes	
Length (mm)	Beam/Column Accommodated
179	203 x 203 UC
186	203 x 133 UB
224	254 x 254 UC
232	254 x 146 UB
275	305 x 305 UC
281	305 x 127 & 165 UB
330	356 x 127 & 171 UB

Example Application in Plan View

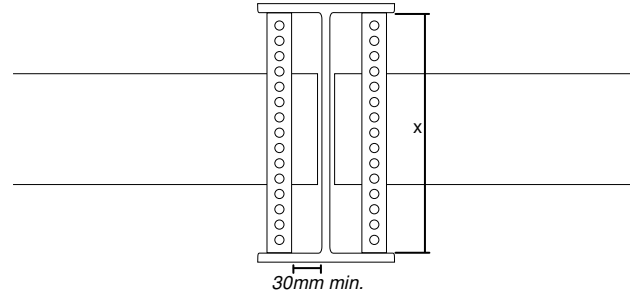

Your Application

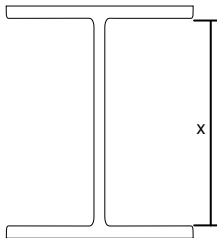

X = _____ mm

Please note: Install at 225mm vertical centres

Quantity required _____ No.

2. Special Internal Column Tie

Used when blockwork sits outside column

Example Design

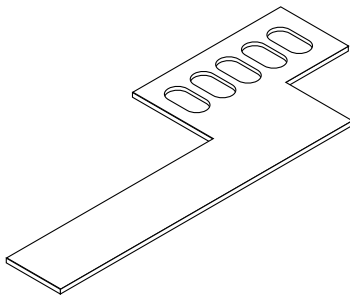

Example Application in Plan View

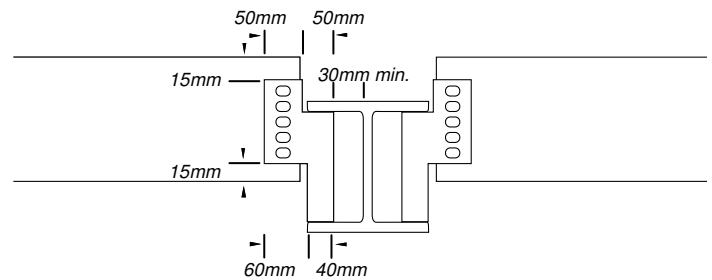

Your Application

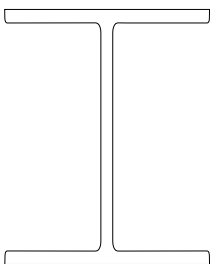

Please sketch your application here and add all necessary dimensions

Quantity required _____ No.

Please note: Install at 225mm vertical centres

3. Your Details

Contact: _____

Company Name: _____

Address: _____

Tel: _____

Fax: _____

Quotation Tick boxes as appropriate

Order Delivery to above address

Fax Back to: +44 (0) 114 276 8543

Ancon Building Products, President Way, President Park, Sheffield, S4 7UR Tel: +44 (0) 114 275 5224 Email: info@ancon.co.uk