

CI/SIB	(21)	Hh	
October 2007			

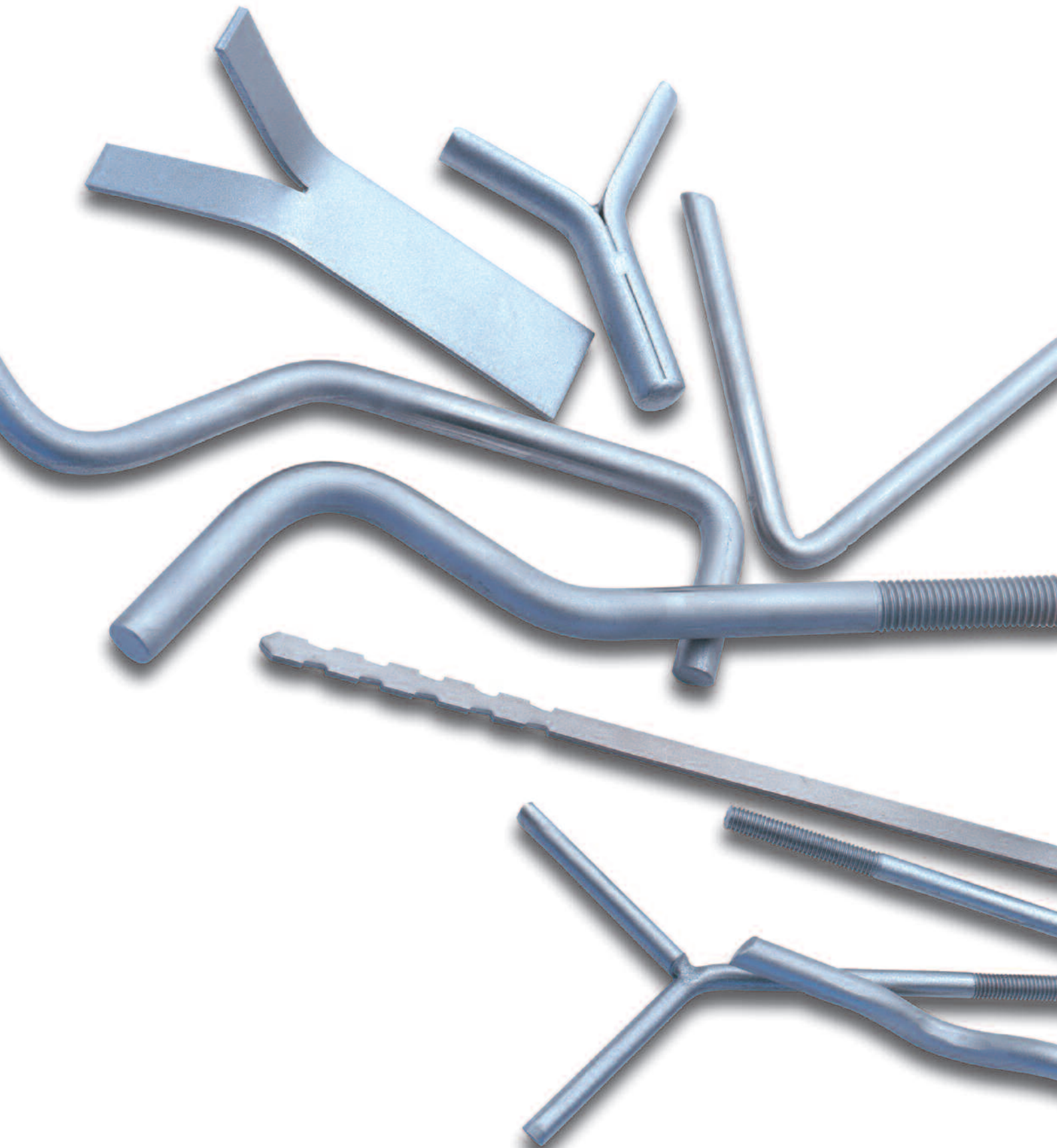

Refractory Fixings for the Heat Treatment Industry

Ancon[®]
BUILDING PRODUCTS



Ancon designs and manufactures high integrity steel products for the construction industry. Through continuous programmes of new product development, inward investment and employee advancement, the company is committed to maintaining the highest level of customer service within a dynamic and challenging industry.



Ancon manufactures fixings for most types of insulation material, such as fibre linings, castable linings and refractory bricks. Standard fixings are available in stainless steel grades 1.4301 (304) and 1.4845 (310), and Inconel 601. Other grades of stainless steel, mild steels and alloys are also available.

Ancon is pleased to advise on the correct selection of fixings and also provides a quick response to quotation requests.

Masonry Support Systems	Materials	4
Windposts and Lintels	Stainless Steel at Elevated Temperatures	4
Wall Ties and Restraint Fixings	Material Specification	4
Channel and Bolt Fixings	Using Stainless Steel at High Temperatures	4
Tension Systems	Refractory Anchor Systems	5
Special Fabrications	Cast-in Anchors	5
Flooring and Formed Sections	Anchors for Brick Installation	6
Shear Load Connectors	Bespoke Anchors	6
Reinforcing Bar Couplers	Mesh Anchors	6
Reinforcement Continuity Systems	Special Fabrications	6
Punching Shear Reinforcement	Ceramic Fibre Fixing Systems	7
Insulated Balcony Connectors		
Refractory Fixings		



ISO 9001: 2000
FM 12226



ISO 14001: 2004
EMS 505377



Refractory Fixings

MATERIALS

Ancon manufactures refractory anchors and fibre fixing systems to exacting tolerances in a wide range of stainless steel and higher alloys. Standard fixings are available in stainless steel grade 1.4301 (304) and grade 1.4845 (310), and Inconel 601. Other grades of stainless steel, mild steels and alloys are available to suit requirements, including Stainless Steel grade 1.4401 (316).

STAINLESS STEEL AT ELEVATED TEMPERATURES

Standard Stainless Steels provide corrosion resistance in a number of aggressive situations. They also provide very good oxidation and scaling resistance at elevated temperatures.

In situations where standard steels reach their temperature limits, higher alloy and specially designed stainless steels provide a combination of increased strength and oxidation resistance, extending the useful working range up to higher temperatures around 1200°C.

Specification	Type 304	Type 310	Inconel™ Alloy 601
Nearest Werkstoff	1.4301	1.4845	-
Maximum service temp. under certain conditions	800°C	1100°C	1150-1230°C
Melting point	1440°C	1490°C	1300-1375°C

Notes: Inconel™ is a trademark of INCO Ltd

Typical Chemical Specification (%)

Specification	Type 304	Type 310	Inconel Alloy 601	Type 309	Type 316	Type 321	330 Alloy	600 Alloy	800H Alloy
Euronorm/ Werkstoff Ref	1.4301	1.4845	-	1.4833	1.4401	1.4878	-	-	-
C	0.040	0.050	0.500	0.060	0.040	0.050	0.060	0.050	0.060
S	0.20 - 1.00	0.20 - 1.00	0.500	1.000	1.000	1.000	1.750	0.500	1.000
Mn	0.50 - 2.00	0.50 - 2.00	1.000	2.000	2.000	2.000	2.000	1.000	1.500
P (Max)	0.045	0.045	-	0.450	0.045	0.045	0.400	0.015	-
S (Max)	0.030	0.030	0.015	0.030	0.030	0.030	0.300	0.015	-
Cr	18.30	25.00	21.00 - 24.00	22.50	16.80	17.30	19.000	14.00 - 17.00	19.00 - 23.00
Al	-	-	1.00 - 1.70	-	-	-	-	-	0.15 - 0.60
Ni	8.70	20.00	58.00 - 63.00	12.50	10.70	9.20	35.000	72.000	30.00 - 35.00
Others	-	-	Cu 0.5 Bal Fe	-	-	Ti less than /equal to 5 x C	-	Cu 0.5	Cu 0.75 max S=0.015 max Al + Ti=0 x 85-1.20
Mo	-	-	-	-	2.20	-	-	-	-
Ti	-	-	0.500	-	-	-	-	-	0.10 - 0.60

MATERIAL SPECIFICATION

Refractory fixings are available in a range of stainless steels and higher alloys:

Grade 1.4301 (304) (18/8)

The most widely used stainless steel grade containing typically 18% Chromium and 8% Nickel as the main alloying elements. This grade has excellent welding properties and is easily formed and fabricated.

Grade 310

A heat resisting steel that combines excellent resistance to both corrosion and oxidation at elevated temperatures. It is resistant to moderate thermal shock and shows high strength at high temperatures.

Inconel Alloy 601

Inconel 601 has an outstanding resistance to corrosion and to high temperature oxidation. The material also has good resistance to aqueous corrosion and high mechanical strength.

Other Grades

Refractory fixings can be supplied in other grades on request, including Stainless Steel grade 1.4401 (316). Please contact Ancon for more details.

USING STAINLESS STEEL AT HIGH TEMPERATURES

The resistance to oxidation of stainless steel depends largely on the chromium content. Two other alloying elements, nickel and silicon, can also be instrumental in enhancing the oxidation resistance of the steels. Nickel in the alloy minimises oxide spalling. Silicon increases oxidation resistance by improving the compaction of the scale formed and thereby allows the steel to be used at higher operating temperatures. Corrosion in air or steam occurs relatively slowly due to the formation of a compact adherent chromium oxide based scale.

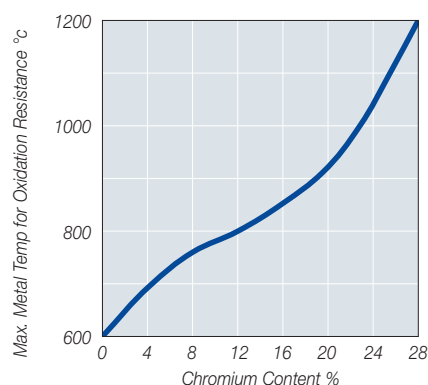

Effect of Chromium Content in Steel on the Resistance to Oxidising Products of Combustion

REFRACTORY ANCHOR SYSTEMS

Ancon manufactures a wide range of refractory anchor fixings to suit any particular application for retaining castable and brick installations.

- Refractory Anchors
- Refractory Brick Fixings
- Special Fixings and Special Fabrications

Manufactured from round bar or plate section, the anchors are available in a number of standard shapes. They are fixed with a thread or a weld, and can be supplied with a weld foot. The fixings are available in the full range of stainless steels and alloys, and can be made to suit any depth of lining.

CAST-IN ANCHORS

'Y' Anchors

These anchors are manufactured from 5-12mm diameter bar or from plate section. 'Y' anchors made from round bar can be supplied open to any angle, with a plain end, weld leg or thread. The tips can be fitted with plastic caps to enable expansion of the tips at temperature. 'Y' anchors from plate section can be supplied open to any angle, or supplied closed for installation of pre-drilled fibreboard or other initial layers prior to opening on site. Anchors can also be supplied pre-welded to a mild steel base plate for ease of installation on site.

'V' Anchors

Manufactured from bar diameter 5-12mm. The anchor legs can be supplied to individual requirements with odd lengths, with bends or crimps, and with plastic end caps.

Crook Anchors

Crook anchors are manufactured from 5-12mm diameter bar. The crook is available with a span of 75mm, 100mm or 125mm. Crook anchors can be supplied with a plain end, weld leg, thread or bent to fit a pre-welded cleat.

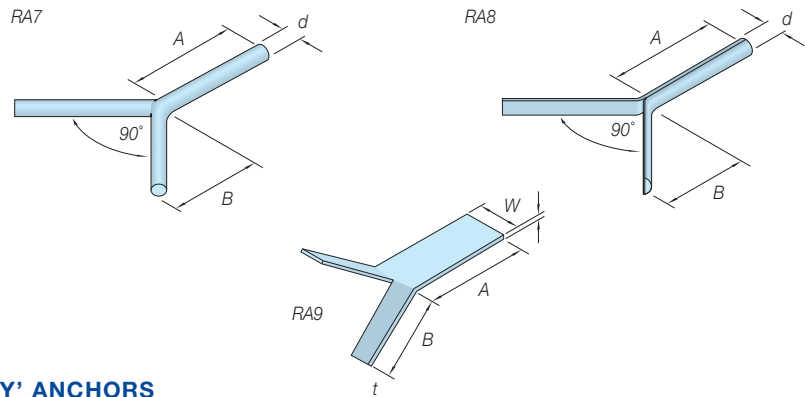

'Y' ANCHORS

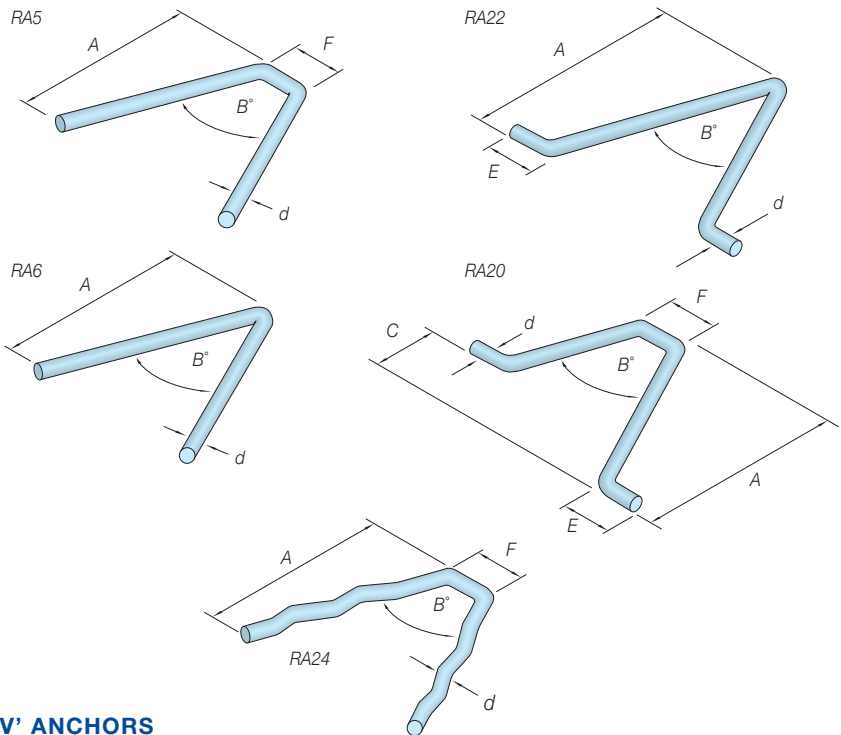

'V' ANCHORS

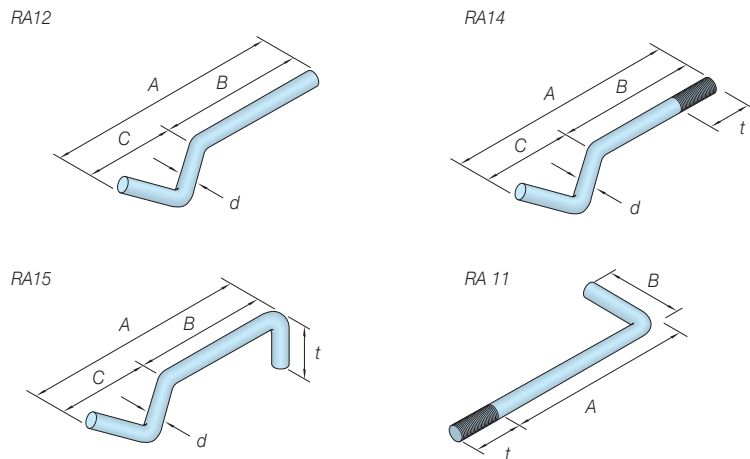

CROOK ANCHORS

Refractory Fixings

ANCHORS FOR BRICK INSTALLATION

A range of refractory fixings for brick installations is available. The anchors are designed to fit refractory bricks, and can be made to customers' specifications to suit any furnace brick. The range includes brick hooks made from bar, C-clips manufactured from plate and 'scissor clips'.

BESPOKE ANCHORS

Bespoke refractory anchors can be made to order, including two part anchors and fixings with multiple anchor legs. Please contact Ancon with your requirements.

MESH ANCHORS

A mesh fixing is available for retaining mesh lining. The fixing is supplied open, and is welded to the furnace lining.

SPECIAL FABRICATIONS

Ancon has many years experience producing special fabrications to individual customer requirements. Bespoke stainless steel refractory fabrications can be designed and manufactured to operate in high temperature environments. These include brickwork support systems for chimney and furnace applications, and incineration components.

Advanced manufacturing equipment and a substantial raw material stock are available to provide a consistently high level of service.

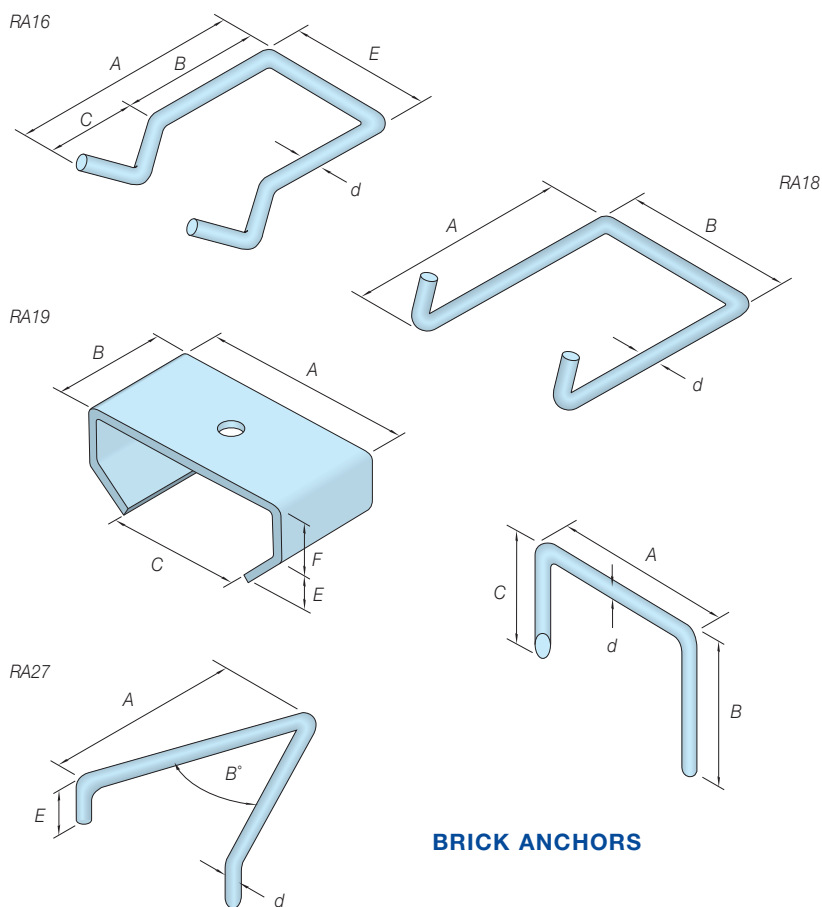

BRICK ANCHORS

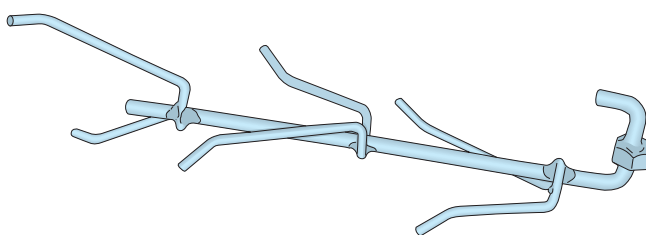

BESPOKE ANCHOR

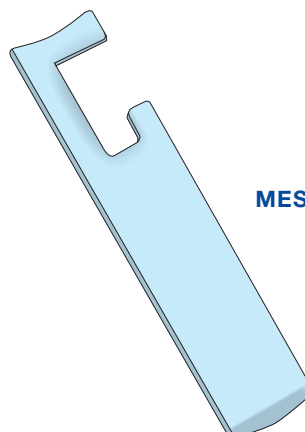

MESH RETAINER

CERAMIC FIBRE FIXING SYSTEMS

A range of fixing systems is available for retaining ceramic fibre layers onto the furnace casing. Fixing studs can be supplied with a plain end or with a weld foot if required.

Twistlock System

Twistlock is a fixing system for ceramic fibre blankets. The standard set comprises a twistlock stud, ceramic arc shield, carbon steel speedfix washer, and a stainless steel twistlock washer. The system provides fast, simple, and secure retention of the lining. The twistlock stud is manufactured from 6.35 x 3.18mm section in lengths from 40mm with notches to retain the twistlock stainless steel washer.

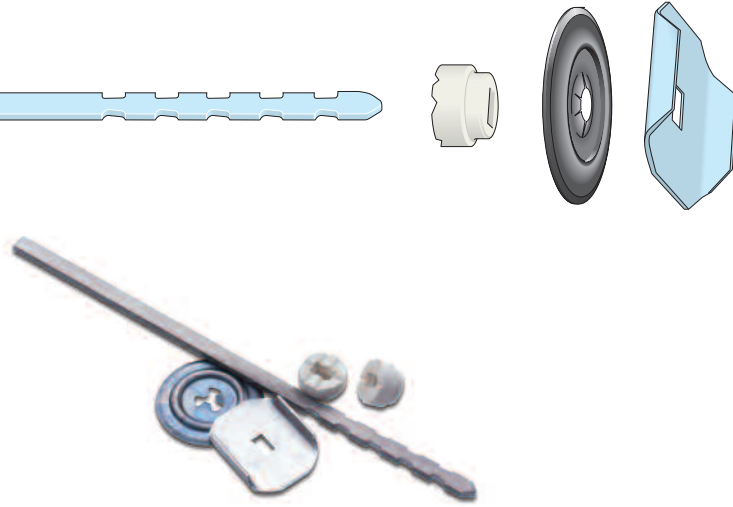

Threaded Fixing System

The threaded fixing system is used for new installations and repairs to existing plant. The standard set comprises an M5 threaded stud, ceramic arc shield, carbon steel speedfix washer, stainless steel clearance washer and M5 hex nut to hold the washer in place. The studs are available in any length from 40mm, and can be supplied fully threaded, threaded one or both ends, and incorporating a weld foot.

Threaded sets are also available in non-standard sizes as M6, M8, M10, M12 and M16.

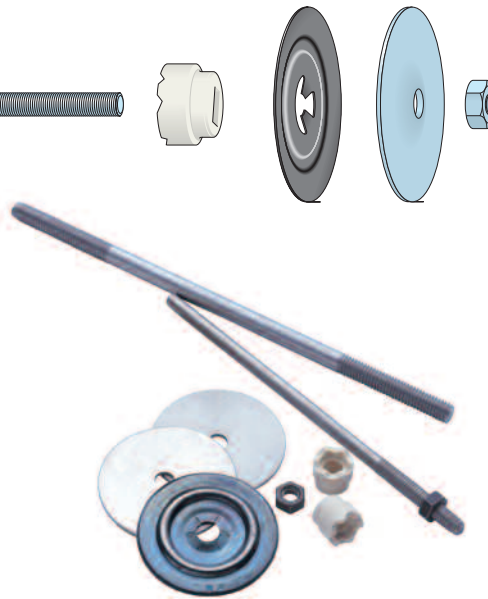

Ancon Building Products

President Way, President Park
Sheffield S4 7UR
United Kingdom
Tel: +44 (0) 114 275 5224
Fax: +44 (0) 114 276 8543
Email: info@ancon.co.uk
Visit: www.ancon.co.uk

Ancon (Middle East) FZE

PO Box 17225
Jebel Ali
Dubai
United Arab Emirates
Tel: +971 (0) 4 883 4346
Fax: +971 (0) 4 883 4347
Email: info@ancon.ae
Visit: www.ancon.ae

Ancon Building Products

114 Kurrajong Avenue
Mount Druitt
Sydney
NSW 2770
Australia
Tel: +61 (0) 2 9675 1000
Fax: +61 (0) 2 8808 1111
Email: info@anconbp.com.au
Visit: www.anconbp.com.au

Ancon (Schweiz) AG

Gewerbezone Widalmi 10
3216 Ried bei Kerzers
Switzerland
Tel: +41 (0) 31 750 3030
Fax: +41 (0) 31 750 3033
Email: info@ancon.ch
Visit: www.ancon.ch

Ancon Building Products GesmbH

Gerspergasse 9/3 Top 1
A-1210 Vienna
Austria
Tel: +43 (0) 1 259 58 62-0
Fax: +43 (0) 1 259 58 62-40
Email: info@ancon.at
Visit: www.ancon.at

Ancon GmbH

Bartholomäusstrasse 26
90489 Nuremberg
Germany
Tel: +49 (0) 911 955 1234 0
Fax: +49 (0) 911 955 1234 9
Email: info@anconbp.de
Visit: www.anconbp.de

These products are available from:

The construction applications and details provided in this literature are indicative only. In every case, project working details should be entrusted to appropriately qualified and experienced persons.

Whilst every care has been exercised in the preparation of this document to ensure that any advice, recommendations or information is accurate, no liability or responsibility of any kind is accepted in respect of Ancon Building Products.

With a policy of continuous product development Ancon Building Products reserves the right to modify product design and specification without due notice.

© Ancon Building Products 2004



ISO 9001: 2000
FM 12226



ISO 14001: 2004
EMS 505377