



We are one team. **We are Leviat.**

Leviat is the new name of CRH's construction accessories companies worldwide.

Under the Leviat brand, we are uniting the expertise, skills and resources of Ancon and its sister companies to create a world leader in fixing, connecting and anchoring technology.

The products you know and trust will remain an integral part of Leviat's comprehensive brand and product portfolio. As Leviat, we can offer you an extended range of specialist products and services, greater technical expertise, a larger and more agile supply chain and better, faster innovation.

By bringing together CRH's construction accessories family as one global organisation, we are better equipped to meet the needs of our customers, and the demands of construction projects, of any scale, anywhere in the world.

This is an exciting change. Join us on our journey.

Read more about Leviat at [Leviat.com](https://www.leviat.com)



Our product brands include:

Ancon[®]

HALFEN

HELIFIX

ISEDIO

PLAKA



60

locations

sales in
30+
countries

3000

people worldwide

Imagine. Model. Make.

Leviat.com

Masonry Support Systems & Lintels for the Construction Industry

Brick, block or stone cladding on framed structures is normally supported by stainless steel support systems. Frame type, differential movement, type of cladding, masonry load and cavity width all need to be considered when designing the most appropriate fixing solution. Contact Leviat's Technical Services Team for advice.

In addition to support angles, a range of Ancon Lintels provide support over door and window openings.



CE Marking

Construction products which fall within the scope of a harmonised European Standard should now carry CE marking under the Construction Products Regulation.

For masonry support systems, the harmonised standard is BS EN 1090-1 Execution of steel structures and aluminium structures: Requirements for conformity assessment of structural components. We comply with all CE marking requirements of this Standard, including designs to EN 1993 (Eurocode 3) and external certification of our factory production controls by an approved body. We are certified to undertake welded fabrication work to Execution Class 2 which covers the vast majority of building applications and is the default class when unspecified.

For lintels, the harmonised standard is BS EN 845-2. Look out for the CE logo on our lintel pages.



Factory Production Control Certificates and Declarations of Performance are available to download from www.ancon.co.uk/CE

Contents

Introduction to Masonry Support Systems	4	Fixing to Steel Frames	17
Introduction to Lintels	5	CombiDeck	18-19
Design Considerations	6-7	CFA Support System	20-21
AnconOptima	8-11	Individual Brackets	22-23
MDC Support System and Thermal Breaks	12-14	Stonework Support	24-27
Fixing modular brick-faced units	15	Lintels	28-33
Fixing to Concrete Frames	16	Channel and Bolt Fixings	34
Fixing to CLT Frames	16	Other Ancon Products	35

Building Information Modelling

BIM objects of Ancon products are now available to download from either www.ancon.co.uk/BIM or the NBS National BIM Library.



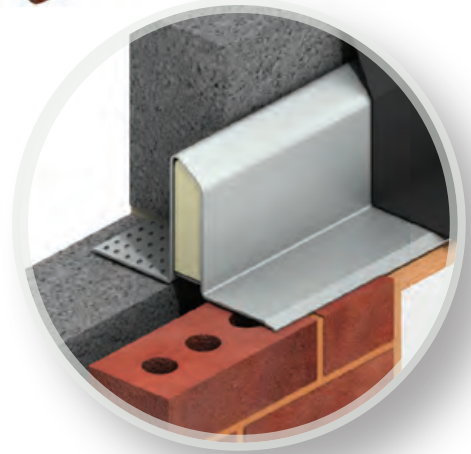
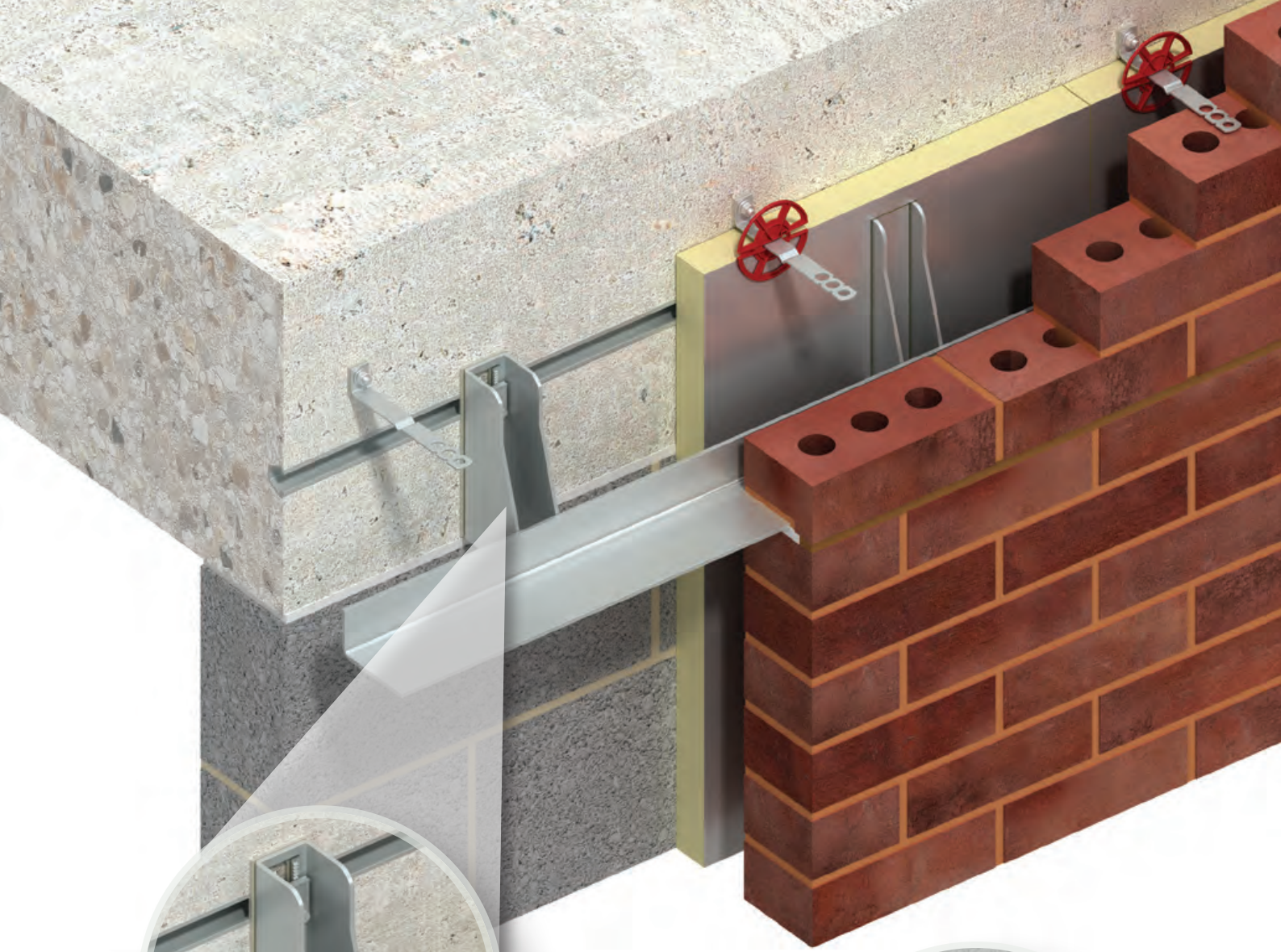

CE Marked to
BS EN 1090-1
BS EN 845-2



Welding
Certification
to Execution Class 2



ISO 9001,
ISO 14001
& ISO 45001



Product Information
in NBS Format



BIM Objects
Available



Class A1
Non-combustible
Stainless Steel



Fire-Tested
Thermal Break
Available



CPD Seminars
Available



Free
Design Service



Ancon and Ibstock-
Kevington Brick
Soffit System



THE QUEEN'S AWARDS
FOR ENTERPRISE:
INTERNATIONAL TRADE
2015



THE QUEEN'S AWARDS
FOR ENTERPRISE:
INNOVATION
2018

Masonry Support Systems & Lintels



Standard AnconOptima System
Fixed to CombiDeck Edge Trim

Masonry Support Systems

Structures with brick or stone cladding will usually necessitate the use of a stainless steel support system for the masonry.



Bracket Angle Support System

AnconOptima is unlike welded systems, the brackets and angles are supplied as separate components. This provides greater flexibility in the final fixing position of the brackets and makes the system easier to handle on site. Standard systems are available to support an unfactored masonry load of up to 14kN/m. Brackets for these systems are stocked to suit cavities from 60mm to 150mm in 5mm increments. They can be changed on site to allow for cavity variations (pages 8-11).

Ancon MDC Systems have welded brackets and are designed to suit specific applications. They are available in various configurations and are ideal for supporting special masonry features. Material content is optimised to ensure the most economic solution is designed (pages 12-14).

Continuous Angle Support System

Ancon CFA Systems are mainly used where cavities are small or there is a requirement for the cavity to be closed at the support position (pages 20-21).

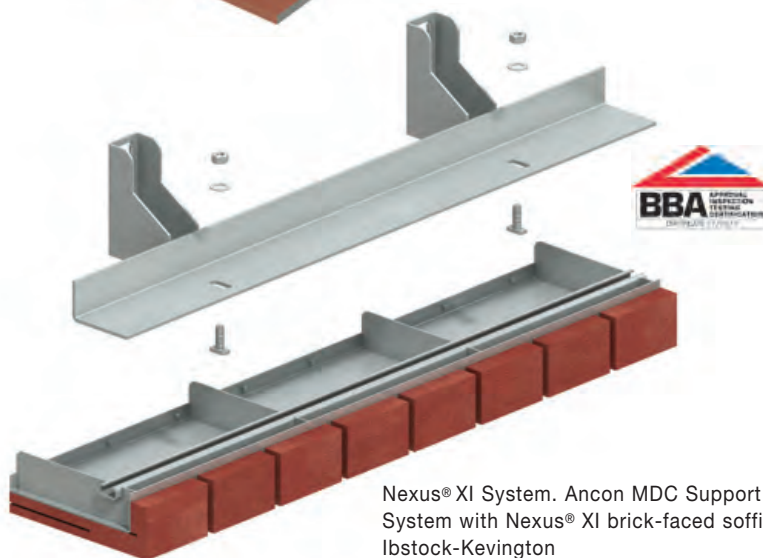

Nexus® XI System. Ancon MDC Support System with Nexus® XI brick-faced soffit from Ibstock-Kevington



CFA/I Support System Fixed to Structural Steel Edge Beam

Individual Bracket Support System

Ancon MDA Individual Brackets provide great flexibility in design. They are ideal for the support of brickwork curved on plan (pages 22-23).

Stonework Support

Natural stone cladding is often a combination of large individually-sized stones and requires particular attention. Ancon MDC/S Stonework Supports can be designed in a variety of configurations to suit the particular application (pages 24-27).



MDA System Supporting Brickwork Curved on Plan



MDC/SC Stonework Support System

Lintels

Ancon Lintels are manufactured from stainless steel and do not require any further corrosion protection (pages 28-33). The standard range is designed to suit the light to heavy duty loading conditions found in the majority of residential and commercial buildings.

Special lintels can be manufactured to suit architectural features and wall constructions not covered by the standard range.



Other Products & Services

Leviat also manufactures CE-Marked Ancon Wall Ties, Windposts, Parapet Posts and Masonry Reinforcement.

Free of charge technical services include advice on product selection, CPD seminars, CAD details and BIM objects. Contact us for further information.



At the end of a long service life, a stainless steel product is 100% recyclable.



Stainless steel typically contains 60% recycled material.

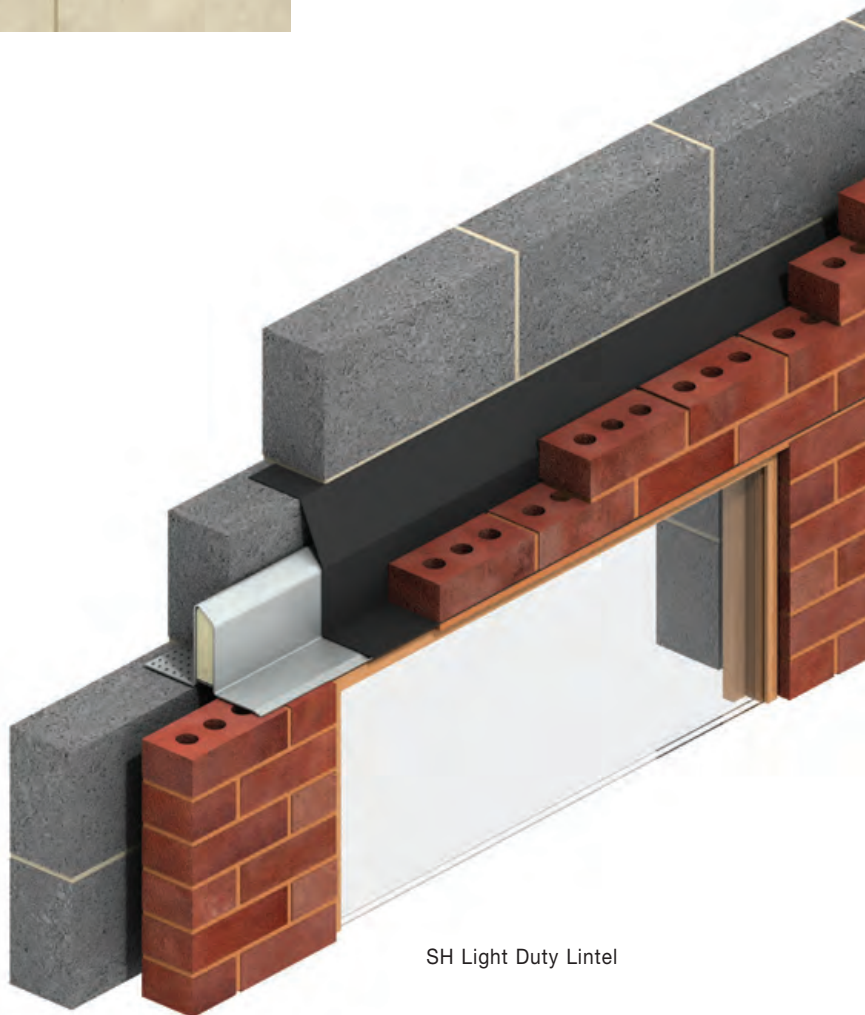

SH Light Duty Lintel

Masonry Support Systems & Lintels

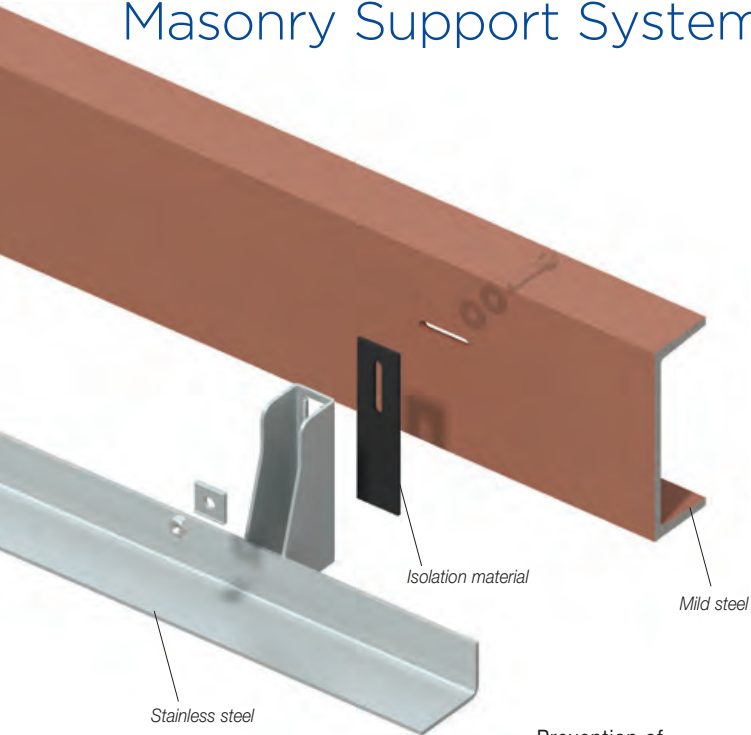

Prevention of Bi-metallic Corrosion

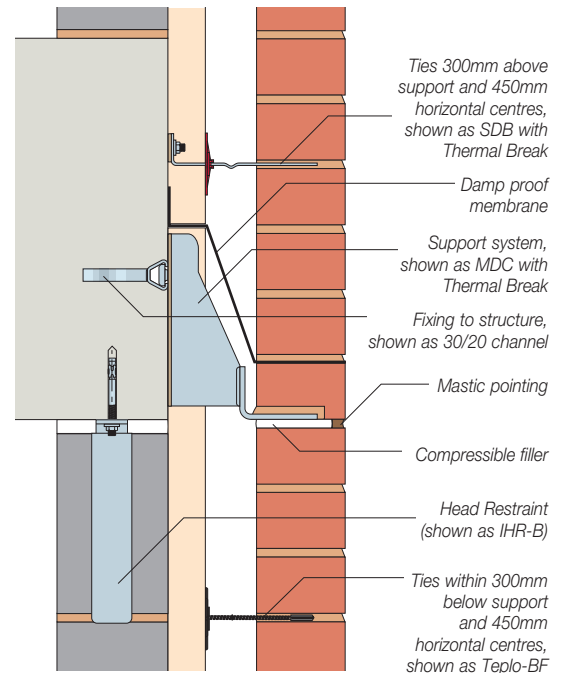

Typical Support Detail

Design Considerations

Structures with brick or stone cladding will usually necessitate the use of stainless steel support for the masonry over horizontal movement joints. Differential movement, corrosion resistance, type of cladding and frame type, all need to be considered.

Differential Movement

The maximum size of a masonry panel should be restricted to limit the effects of differential movement. This is particularly important if clay brickwork is used with concrete blockwork and a concrete frame. The outer leaf of buildings not exceeding four storeys or 12 metres in height, whichever is less, may be uninterrupted for its full height. For other buildings, the outer leaf should be supported at intervals of not more than nine metres or three storeys, whichever is less, as stated in BS 5628 : Part 1 which, since the withdrawal of this British Standard, remains best practice. To allow for a vertical movement of around 1mm per metre, movement joints are generally positioned at every storey or every second storey. They are also incorporated in many buildings of less than four storeys or 12 metres in height.

Horizontal Movement Joints

The support will be positioned directly over the horizontal movement joint. The joint will often incorporate a compressible filler and should be of sufficient size to allow for expansion of the masonry below and any shrinkage or deflection of the structural frame. The underside of the support system should be positioned around 2mm above the joint to

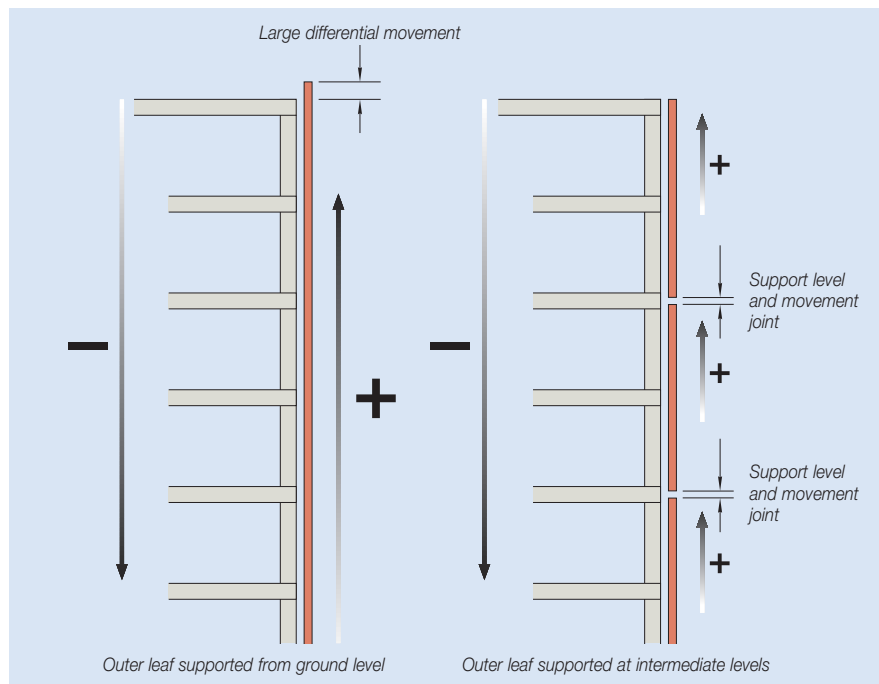

Differential Movement Between Masonry Cladding and Frame

allow for the support leg to settle when supporting the brickwork above. The clear joint below should be at least 10mm where there is a single storey height of brickwork below the support system. Where there are two storeys or more of brickwork below the support system, the clear joint should be sufficient to accommodate all expected movements. This may result in clear joints in excess of 10mm. Damp-proofing is normally located at the support position. Wall ties should be incorporated within 300mm above and below the support.

Fixing Methods

There are various methods of fixing Ancon Support Systems to the structure. Cast-in channels with 'T' bolts or site drilled expansion bolts can be used with concrete frames. For steel frames the choice is set screws or Ancon Steelgrip into holes in the steel edge member, or where there is a metal deck floor, Ancon CombiDeck has a horizontal channel that accepts 'T' bolts. A range of suitable fixings is included on page 34. Further information is given on pages 16 to 17, and in the Ancon Channel and Bolt Fixings brochure.

Tolerances

It is important to select the correct support system to ensure that building tolerances can be accommodated. Adjustment will be required in all three planes.

Ancon brackets have a slot at the back to provide vertical adjustment. A serrated surface prevents any slip. Longitudinal adjustment is provided by an Ancon cast-in channel in concrete structures, or horizontally slotted holes in steel framed structures. The AnconOptima System features a fixing zone providing a total of 50mm horizontal adjustment allowing the system to be fixed to pre-drilled holes rather than slots in steelwork and eliminates clashes with reinforcing bars in concrete.

Subject to the type of fixing used, AnconOptima brackets can be changed on site to suit variations in the structural edge beam. Other systems accommodate such variations by adding shims between the system and the structure, or by increasing the bearing of the brickwork. The maximum thickness of shims should not exceed the outside diameter of the fixing or 16mm, whichever is less.

Corrosion Resistance

Ancon Support Systems are manufactured from grade 1.4301 (304) stainless steel and will be suitable for most building applications. In particularly corrosive environments, or where part of the support will be visible, grade 1.4401 (316) should be considered. Bi-metallic corrosion may occur in a damp environment where the stainless steel support system is bolted to the structural steel frame. This will not affect the stainless steel, but could slightly increase the corrosion rate of the carbon steel. This can be prevented by excluding moisture from the detail, or by isolating the two dissimilar metals. Isolation patches are available from us for use with Ancon Support Systems. Further information is given in our brochure, 'The Use of Stainless Steel in the Construction Industry'.

CE Marking

Ancon masonry support systems carry CE marking to BS EN 1090-1 confirming design to EN 1993 (Eurocode 3) and manufacture at facilities externally audited by an approved body. Contact us or visit www.ancon.co.uk/CE for details.



Adjustment of MDC Support System Fixed to Concrete

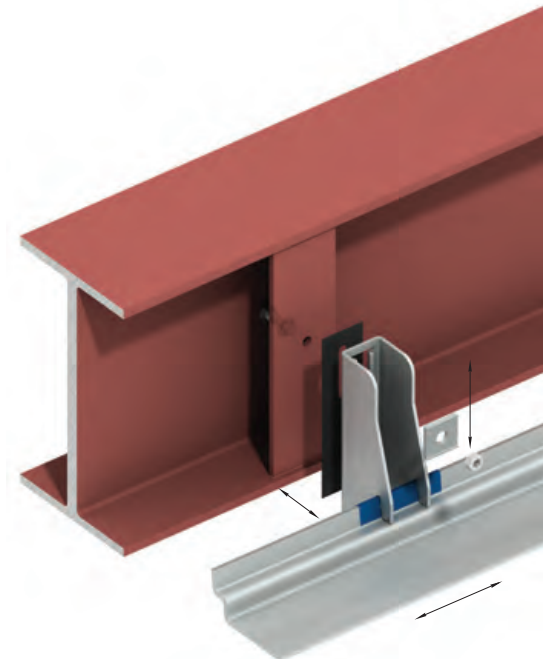

Patent No. EP 1211364
Adjustment of AnconOptima Fixed to Steelwork

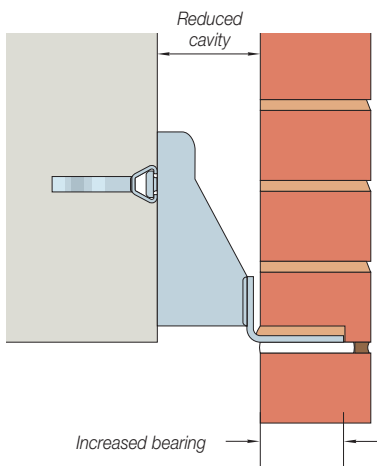

Increased Bearing Used to Accommodate Reduced Cavity

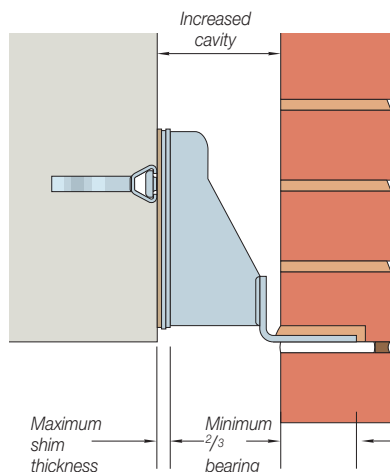

Shims Used to Accommodate Enlarged Cavity. Shim closest to the structure shown as Thermal Break

Manufacturing Tolerances

Unless otherwise agreed, the tolerances applicable to cold formed sections are shown in the table below.

Element	Tolerance
Overall length	±5mm
Thickness	±7.5%
Leg length of angle	±3mm
Angle between legs	±2°
Hole or slot centre	±5mm
Mitred corners	±1°
Bow on either axis	±3mm per metre length

Masonry Support Systems & Lintels



Standard AnconOptima 14 System.
Standard Brackets, Locking Wedges and
a 790mm Angle with Blue Fixing Zones



Patent No. EP 1211364



AnconOptima

The Industry's growing emphasis on speed of construction, and the inability of welded bracket support systems to provide sufficient adjustment on site, led us to develop AnconOptima.

AnconOptima is a bracket angle masonry support system. Unlike welded systems, the brackets and angles are supplied as separate components. This provides greater flexibility in the final fixing position of the brackets and makes the system easier to handle and move around site.

Systems comprise laser-cut brackets, two-step angles with pre-marked fixing zones and locking wedges to ensure the correct contact is achieved between the two.

AnconOptima Systems can be used with the standard Thermal Break (see page 13) to reduce cold bridging.

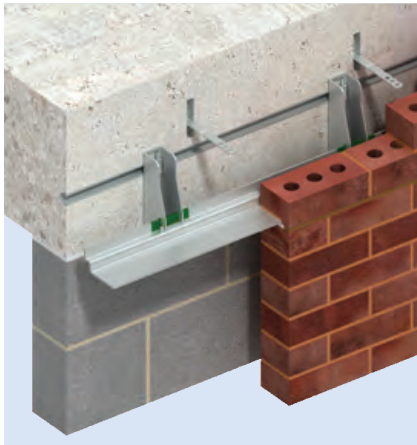

AnconOptima 12 System



Standard Systems

Standard systems, referenced AnconOptima 10, 12 and 14, support an unfactored masonry load of up to 10kN, 12kN and 14kN per metre respectively. All components are available from stock.

Brackets are available to suit cavities from 60mm to 150mm and are stocked in 5mm increments. Brackets can be changed on site for one of a different depth to allow for cavity variations. Two brackets of a different depth can be used on the same angle.

The brackets used across the three standard systems are universal. The differing performance of the three systems is generated by the varying length and thickness of the angle and the fixing centres of the brackets.

Left-hand and right-hand corners are available.

Not being specific to a particular project, unused components can be moved to another project or, for a small restocking charge, returned to us.

Standard AnconOptima systems are specified from the simple load/cavity charts shown on page 11. Please note the fixing type may affect the maximum masonry load of the system specified.

Non-Standard Systems

AnconOptima was conceived by our technical staff primarily as a standard solution for unfactored loads up to 14kN/m, however it can be designed to suit other applications. Although the components of a non-standard AnconOptima system are not available from stock and cannot be returned to us for restocking, they still provide greater flexibility in the fixing position and are less cumbersome to handle on site than a comparable welded bracket system.

Typical applications of a non-standard AnconOptima system are unfactored loads up to 20kN/m or where a different angle position on the bracket is needed e.g. projecting angle.

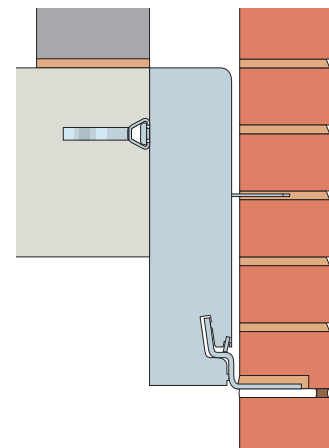

Bespoke AnconOptima/P Support System



Cavity Variations

The ability of welded bracket support systems to accommodate variations in the line of the structure is limited by the maximum thickness of shims, normally 12mm. Some additional adjustment will be possible by varying the bearing of the brickwork on the support angle but this will be very limited, particularly where pistol bricks are used.

When using a standard AnconOptima system, brackets are available from stock to suit cavities from 60mm to 150mm in 5mm increments. They can be changed on site to allow for variations in the edge beam. Shims can be used for fine adjustments and should never need to be more than 4mm thick.

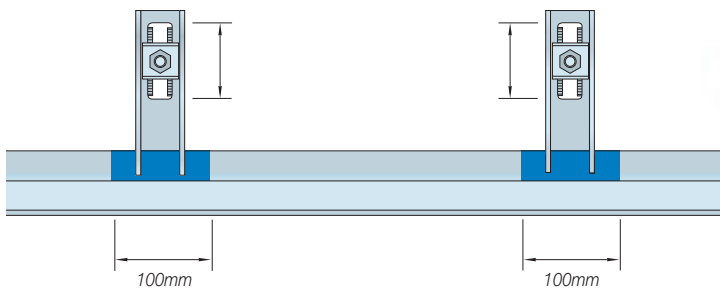

Adjustment of AnconOptima

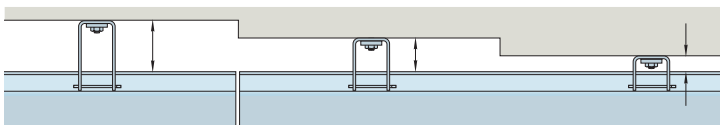

AnconOptima accommodates variations in the line of the edge beam. Brackets of a different depth can be used on the same angle

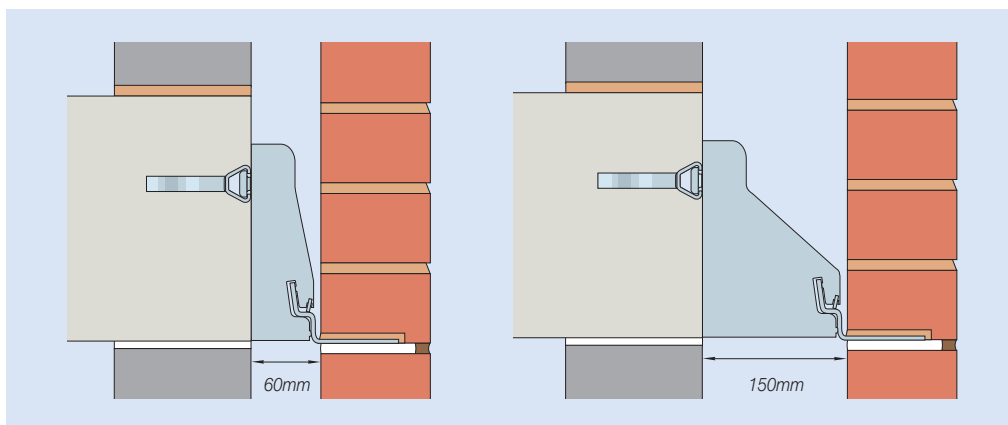

Standard brackets are available to suit cavities from 60mm to 150mm

Vertical Adjustment

Vertical adjustment is achieved by the deep slot in the back of the bracket.

Horizontal Adjustment

AnconOptima angles have a 100mm pre-marked fixing zone which provides 50mm horizontal adjustment.

If fixing into concrete with expansion bolts, the bracket can be moved to eliminate clashes between the bolts and reinforcing bars.

Horizontal adjustment can be increased by fixing the system to an Ancon channel cast into the face of the concrete.

If fixing to steelwork, the brackets can be moved to align with the location of a hole, negating the need for a more expensive horizontal slot to be provided.

Benefits of Standard Systems

- More adjustable than welded bracket systems
- Specified by using simple load/cavity charts
- No requirement for detailed layout drawings
- Supplied from stock
- Faster to install
- Easier to move around site
- Unused items can be used on the next project or restocked

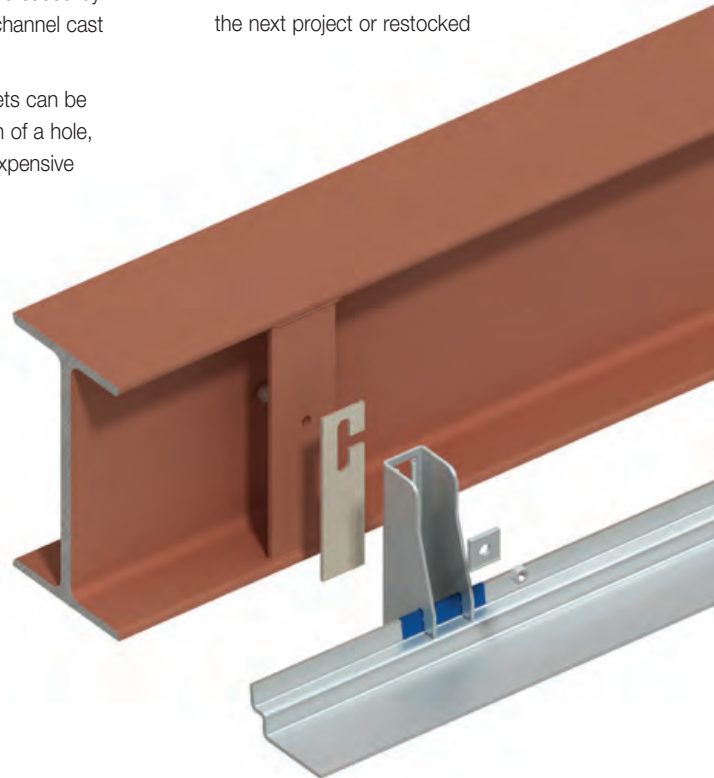

AnconOptima fixed through hole, rather than slot, in steelwork. Adjustment provided by fixing zone on angle. Shown with Ancon Thermal Break which also isolates the dissimilar metals

Masonry Support Systems & Lintels



Setting Out of Standard Systems

Unlike bespoke systems, there is no time-consuming setting out of individually referenced components with a standard system to a detailed layout drawing.

Cutting on site

Standard AnconOptima systems are not designed for specific buildings and certain angles will need to be cut on site to suit the length required. Each angle section must have at least two brackets.

Corners

Left-hand and right-hand corners are available. Each corner section requires three brackets in order to achieve the required performance. These sections should never be cut. Where corner arrangements are required, contact our Technical Team for further guidance.

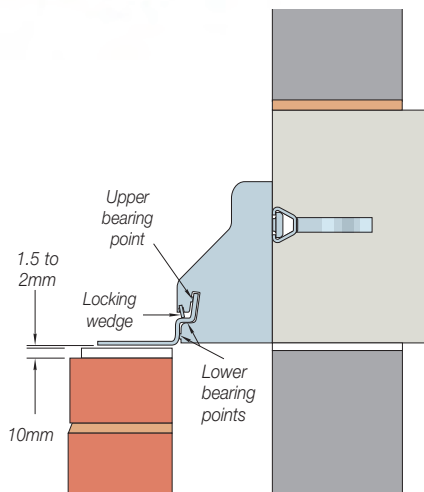

Correct installation of AnconOptima

Installation

Installation of AnconOptima provides significant time savings over welded support systems. The individual components are easier to move around site, often without hiring crane time. The preferred technique of installers is to level and fix two brackets and simply slide the angle into position. This reduces the time spent tightening and loosening the fixing bolts of a welded bracket system, in order to achieve a level horizontal shelf. Where space limitations prevent the angle from sliding, the brackets can be positioned on the angle and conventionally fixed; the smaller lengths of angle simplify this method of installation. When the brackets and angle are in position a locking wedge is tapped with a hammer through the notches in each bracket. These wedges ensure the correct contact is achieved between angle and brackets. A detailed installation guide is available from us.

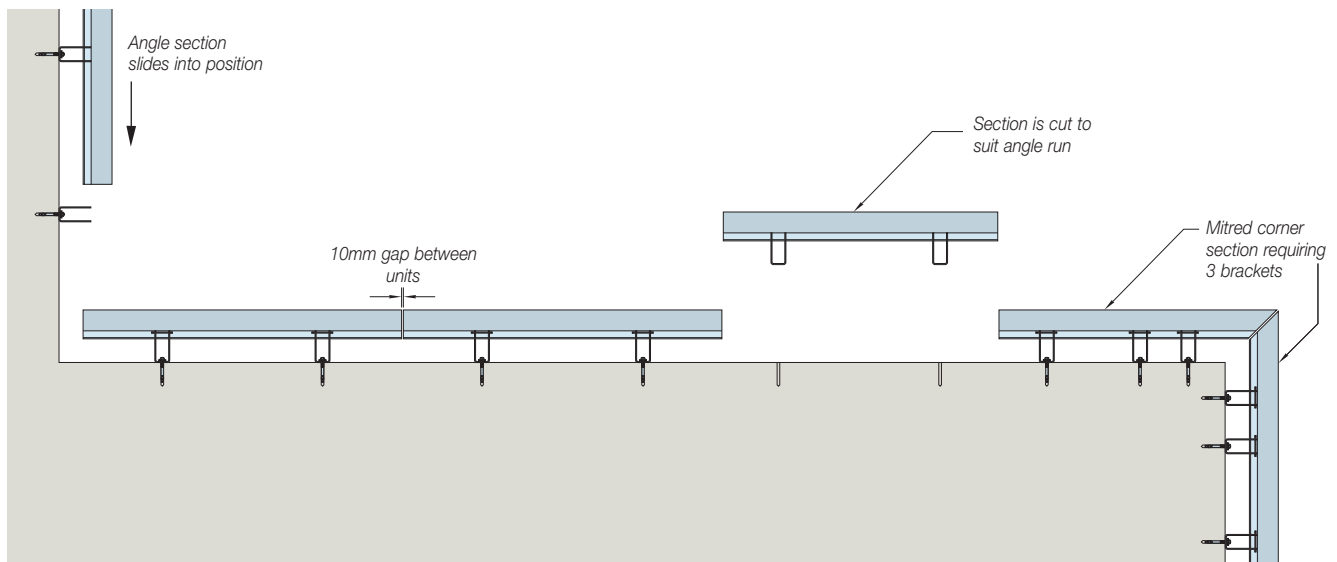

Typical AnconOptima layout

Details for Specifying and Ordering

Standard AnconOptima Systems simplify the total supply process. They consist of standard components, all available from stock, and can be specified by using the simple load/cavity charts below. Specification does not involve the completion of detailed layout drawings and not being specific to any project, excess items from one site can be used elsewhere.

Standard Brackets

AnconOptima brackets are readily available from stock to suit cavities from 60mm to 150mm in 5mm increments. Brackets for wider cavities are available on request. A locking wedge is supplied with each bracket to ensure the correct contact is achieved between angle and bracket.

Standard System Specification Clause

Delete items shown in *italic* as applicable.

AnconOptima 10/12/14 standard masonry support system comprising a 'W' profile stainless steel angle complete with slide on, interchangeable fixing brackets to suit varying cavity width and locking wedges.

Fix back to *concrete/steelwork* using *expansion bolts/cast-in channel/stainless steel set screws/Steelgrip™*.

System to be installed in accordance with our instructions.

Manufactured in Grade 1.4301 (304) Austenitic Stainless Steel.

Building Information Modelling

BIM objects of AnconOptima are available from www.ancon.co.uk/BIM



Advisory Note

These load/cavity tables are designed to provide guidance only. The suitability of any AnconOptima system should be confirmed with our Technical Services Team.

Edge distances, in particular, are critical to performance.

Higher Load Systems and Bracket Variations

Contact us for applications outside the parameters in the tables. Although designed primarily as a standard solution for unfactored loads up to 14kN/m, AnconOptima components can be supplied to suit loads up to 20kN/m and be manufactured with a different angle position on the bracket.

Standard AnconOptima Systems

System	Maximum Unfactored Load (kN/m)	Angle Length (mm)	Nominal Length (mm) <small>(including 10mm gap between angles)</small>	Fixing Zone Colour	Bracket Position (mm)
AnconOptima 10	10	990	1000	Red	500 centres
AnconOptima 12	12	990	1000	Green	500 centres
AnconOptima 14	14	790	800	Blue	400 centres

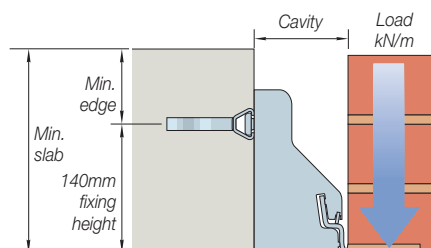

AnconOptima 10

Fixing	Min. top edge (mm)	Min. slab (mm)	Maximum unfactored load (kN/m) for various cavity widths (mm)																				
			60	65	70	75	80	85	90	95	100	105	110	115	120	125	130	135	140	145	150		
30/20 channel	75	215	10	10	10	10	10	10	10	10	10	10	10	10	10	9.8	9.6	9.4	9.2	9.0	8.8	8.7	8.5
FAZII 12/30	75	215	10	10	10	10	10	10	10	10	10	10	10	10	10	10	10	10	10	10	10	10	10
M12 Setscrew	-	-	10	10	10	10	10	10	10	10	10	10	10	10	10	10	10	10	10	10	10	10	10
M12 Steelgrip™	-	-	10	10	10	10	10	10	10	10	10	10	10	10	10	10	10	10	10	10	10	10	10

AnconOptima 12

Fixing	Min. top edge (mm)	Min. slab (mm)	Maximum unfactored load (kN/m) for various cavity widths (mm)																			
			60	65	70	75	80	85	90	95	100	105	110	115	120	125	130	135	140	145	150	
30/20 channel	75	215	10.1	12	11.8	11.6	11.3	11.1	10.9	10.6	10.4	10.2	10	9.8	9.6	9.4	9.2	9.0	8.8	8.7	8.5	
FAZII 12/30	75	215	10.1	12	12	12	12	12	12	12	12	12	12	12	11.7	11.4	11.2	11.0	10.7	10.5	10.3	
FAZII 12/30	105	245	10.1	12	12	12	12	12	12	12	12	12	12	12	12	12	12	12	12	12	12	12
M12 Setscrew	-	-	10.1	12	12	12	12	12	12	12	12	12	12	12	12	12	12	12	12	12	12	12
M12 Steelgrip™	-	-	10.1	12	12	12	12	12	12	12	12	12	12	12	12	12	12	12	12	12	11.8	11.7

AnconOptima 14

Fixing	Min. top edge (mm)	Min. slab (mm)	Maximum unfactored load (kN/m) for various cavity widths (mm)																		
			60	65	70	75	80	85	90	95	100	105	110	115	120	125	130	135	140	145	150
30/20 channel	75	215	12.8	14	14	14	14	13.9	13.6	13.3	13	12.8	12.5	12.2	12	11.8	11.5	11.3	11.1	10.8	10.6
FAZII 12/30	75	215	12.8	14	14	14	14	14	14	14	14	14	14	14	14	14	13.7	13.4	13.1	12.9	12.6
FAZII 12/30	105	245	12.8	14	14	14	14	14	14	14	14	14	14	14	14	14	14	14	14	14	14
M12 Setscrew	-	-	12.8	14	14	14	14	14	14	14	14	14	14	14	14	14	14	14	14	14	14
M12 Steelgrip™	-	-	12.8	14	14	14	14	14	14	14	14	14	14	14	14	14	14	14	14	14	14

Notes to above tables: Tables for straight runs only and based on C30/37 concrete, cracked. For guidance on corner arrangements, please contact us. Minimum slab thickness assumes the support angle is level with the bottom of the slab. A thicker slab will be required where this is not the case. FAZII 12/30 is an Ancon High Performance Bolt. See page 34 and the Ancon Channel & Bolt Fixings literature for further details.

Masonry Support Systems & Lintels



MDC Standard Support System

Ancon MDC Bracket Angle Support System

Ancon MDC Bracket Angle Support Systems can carry over 8 metres of brickwork and accommodate any width of cavity from 50mm in its standard form. The brackets are welded to the angle and the material content of both components is optimised to ensure the most economic solution is designed.

Design Variations

The Ancon MDC System can be supplied in a variety of configurations to suit particular applications and support special masonry features. The size of the support angle can be varied to suit the thickness and height of the masonry to be carried. Bracket spacing, depth and height are all varied to suit loadings, fixing position and cavity width.

There are several variations of the standard MDC System. MDC/P has the bracket projecting below the structure, MDC/R has a reversed angle welded to the bracket, and MDC/I is a specially inverted system with the support angle at the top of the bracket. These variations allow the support leg of the angle to be positioned anywhere from the top of the bracket to a position below the bottom of the bracket. Non-standard AnconOptima can also be supplied in these variations (see page 8).

Brick reveals and soffits are easily created by simply lifting and bolting factory-made brick-faced steel or precast concrete units to the underside of the MDC angle. For in-situ construction, the MDC system can be designed with stirrups, stitching rods and soffit angles.

The Ancon MDC System can be supplied with extra components to suit the application e.g. closer plates, expanded metal etc.

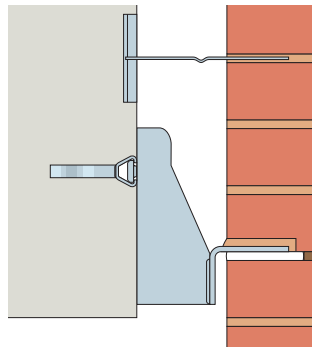

MDC/R Support System

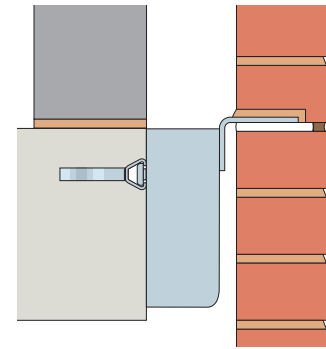

MDC/I Support System

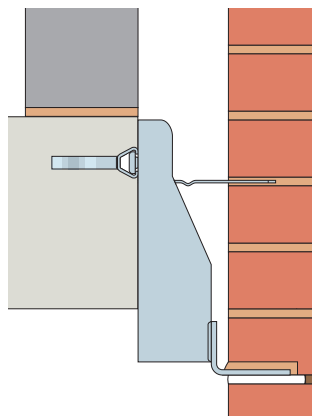

MDC/P Support System

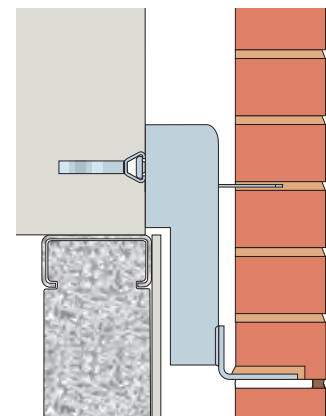

MDC/P/NB Support System

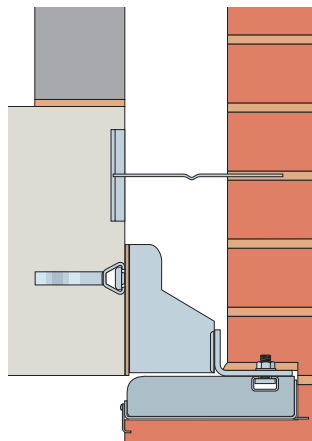

MDC Nexus® XI Support System

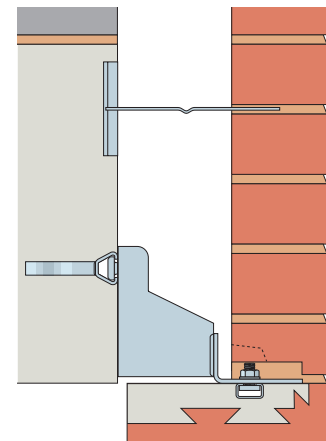

MDC with Precast Masonry Unit

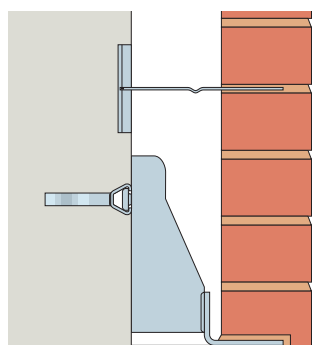

MDC with Closer Plate Welded to Underside

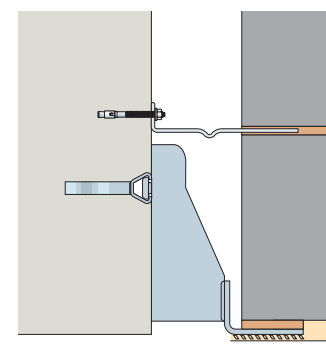

MDC with Expanded Metal Welded to Underside

Adjustment of MDC Support System

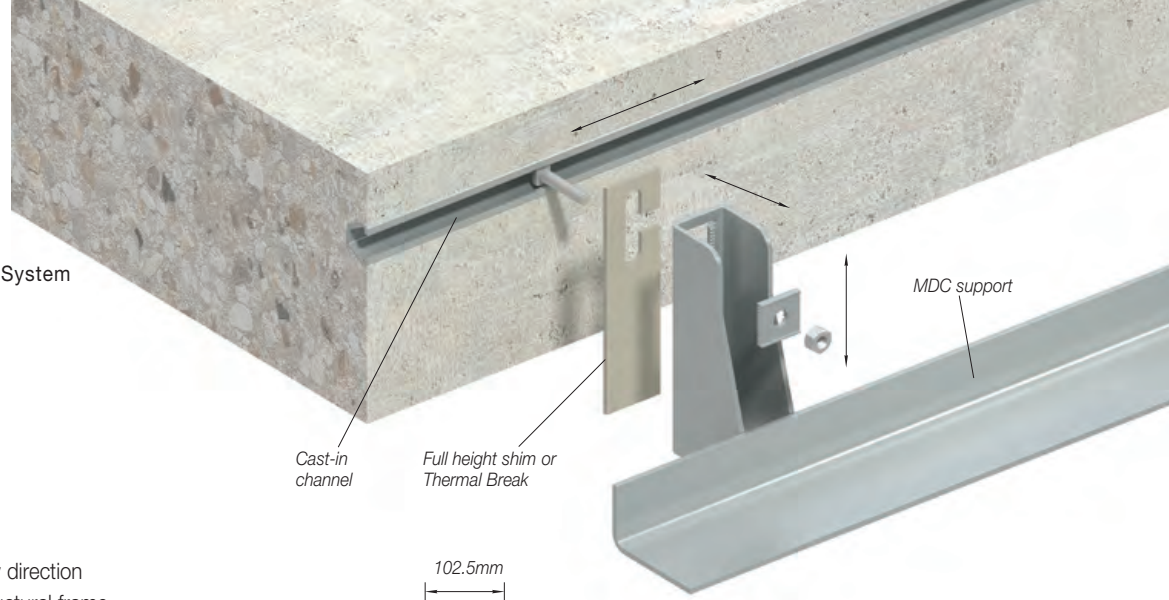

Adjustment

Adjustment is provided in every direction to allow for tolerance in the structural frame. The serrated and slotted face of the bracket allows for vertical adjustment. Cast-in channel will provide virtually unlimited horizontal adjustment; slotted holes in a steel edge member will offer more limited adjustment. Shims can be included between the bracket and the frame up to a maximum thickness of the outside diameter of the fixing bolt, or 16mm, whichever is less. When used, the 3mm thickness of an Ancon Thermal Break should be taken into account when calculating the maximum shimming allowance for a system.

Extension Plates

As an alternative to shims, Ancon Extension Plates can sometimes be used to increase the bearing for the brickwork. The support leg of the angle must provide a minimum of 52mm bearing for standard single skin brickwork for the entire length of the support. Without this bearing the brickwork may become unstable. This must be checked before work proceeds. The extension plates are pushed onto the leg of the angle with the flat surface on top. They are adjusted until the required amount of extension is achieved, this will be from 5mm to 17mm.

The plates can provide extra bearing but they should not extend more than 17mm from the front of the angle. Extension plates are usually 400mm long and fixed with a nominal gap between the plates of approximately 10mm.

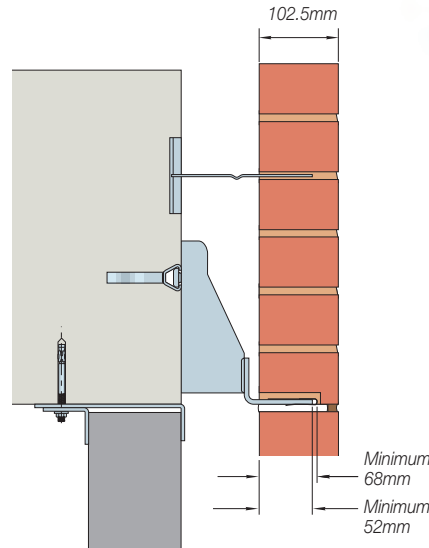

Extension Plate Fixed to MDC Support System

Ancon Extension Plates are designed to be used with Ancon Support Systems. The particular application should be agreed with our technical staff to ensure that both the support system and extension plates are suitable. Contact our Technical Services Team for more information.

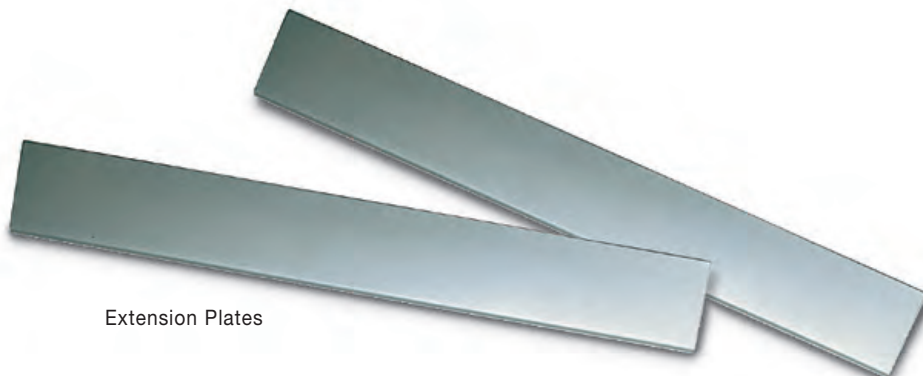

Extension Plates

Fire-Tested Thermal Breaks

Ancon masonry support systems can be supplied with thermal breaks which are positioned between the structural frame and each support bracket. These thermal breaks minimise the cold bridging effect of the structural stainless steel support angle penetrating the insulated building envelope.

They have been independently tested and verified as "A2-s1,d0 reaction-to fire classification" which is fully compliant with The Building (Amendment) Regulations 2018 – the Government's ban on combustible materials in external walls of high-rise residential buildings.

Shaped like a standard key-hole shim, Ancon thermal breaks are easy to install from the side, prior to the fixing bolt being fully tightened.

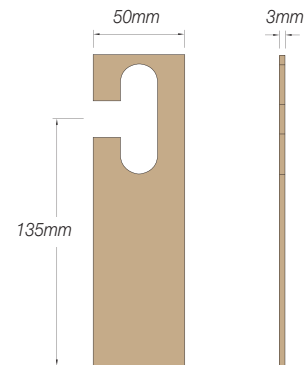

Ancon Thermal Break, ref. BK03

The standard Ancon Thermal Break, as illustrated, can be ordered using the product code 'BK03-135'. This product is suitable for standard AnconOptima support brackets and most Ancon MDC-type brackets.

Thermal Breaks can be specified with a support system using the suffix 'BK03':

MDC / Cavity / Unfactored Masonry Load / Projection / Thermal Break

e.g. MDC / 75 / 8.2 / P75 / BK03

Non-standard Thermal Breaks can be designed to suit any Ancon support system. Contact the Technical Services Team for more information.

Masonry Support Systems & Lintels



MDC/R Support System

Setting Out

We can provide drawings showing the location of the fixings (cast-in channels for concrete frames, bolt positions for steel frames). Bracket angle units will be referenced and scheduled and all details submitted for approval before manufacture.

Details for Specification and Ordering

Ancon MDC Systems are tailored to suit each contract, and are based on the cavity size at the support and the unfactored masonry load to be carried. We will design an economical configuration of channel, bracket and angle. Specification is as follows:-

MDC / type / cavity / unfactored masonry load

e.g. MDC / R / 75 / 5.6

We will design a system with a reversed angle to suit a 75mm cavity and carry 5.6 kN/metre load (unfactored).

References

MDC Standard system

MDC/BK03 System with Thermal Break

MDC/R System with reversed angle

MDC/I Inverted system

Some applications demand that the support leg is below the soffit of the structure. Where this is no more than 150mm, this can be specified as a suffix to the standard reference by **P projection.**

MDC / cavity / unfactored masonry load / projection

e.g. MDC / 125 / 7.2 / P 75

We will design a standard system to suit a 125mm cavity, carry 7.2kN/m (unfactored), with a bracket projection of 75mm.

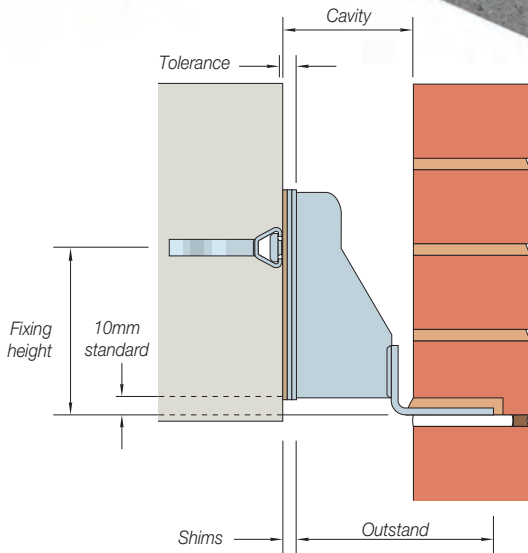

MDC Support System with Shims including a Thermal Break

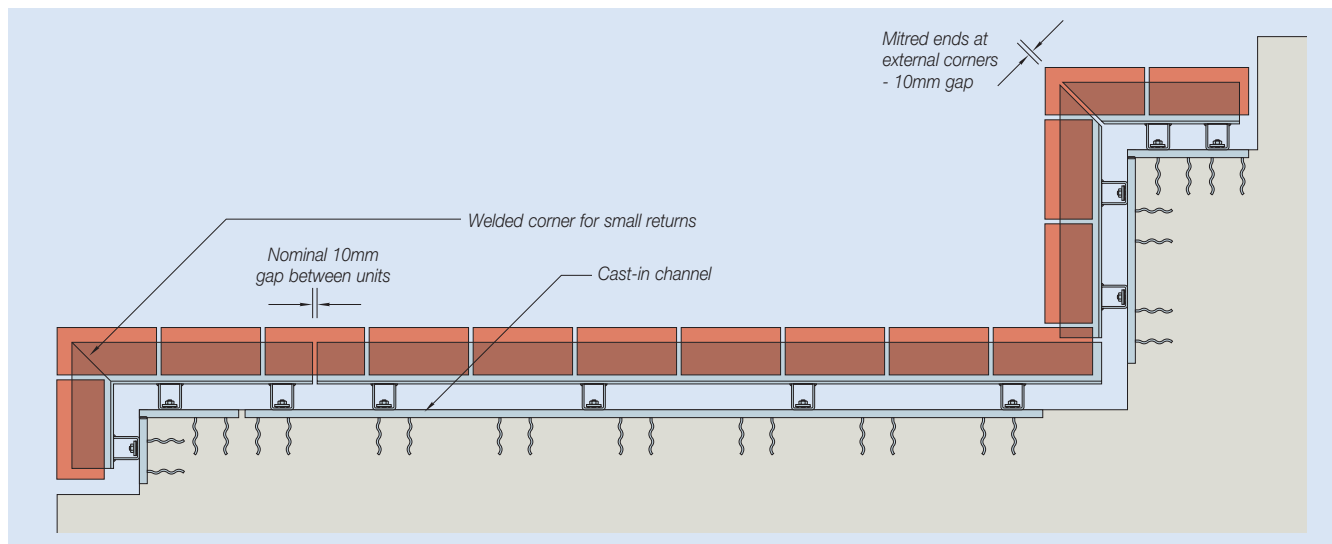

Typical Layout of MDC Support System

Modular Brick-Faced Units

Ancon MDC systems can be designed and manufactured to support modular factory-made brick-faced units, where brick slips are adhered to either steelwork or precast concrete. The units are simply bolted to the underside of the prefixed support angle. This two-part process provides maximum adjustability, both vertically and horizontally, to ensure alignment.

Lightweight Nexus® System

The BBA approved family of Nexus brick-faced soffit and lintel systems brings together a high integrity steel Ancon support system with prefabricated brick-faced units from Ibstock Kevington.

Its lightweight design sees weight cut by more than half when compared to traditional precast concrete alternatives, and its ease of handling ensures it can be installed without the use of specialist lifting equipment.

Typical Nexus® Solutions

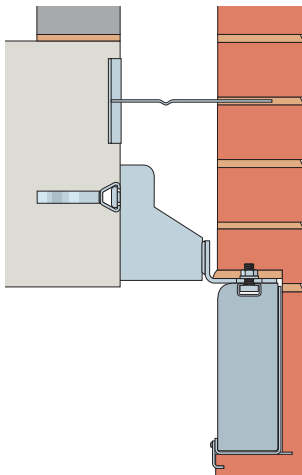

Nexus® XI Soffit 215 x 102mm with Soldier Bond

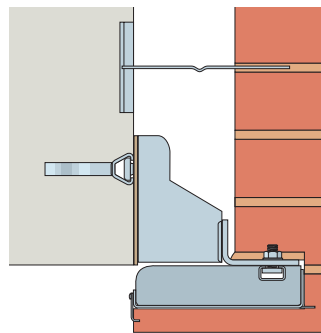

Nexus® XI Soffit 65 x 215mm with Header Bond

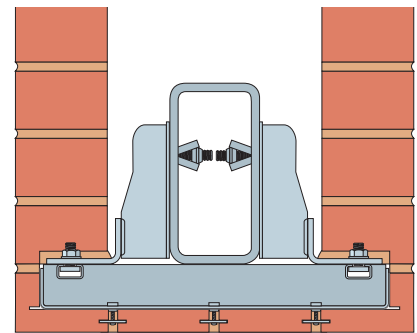

Nexus® XI Soffit 65 x 440 x 65mm with Stretcher Bond

Precast Concrete Systems



Ancon MDC support system fixed to precast concrete brick-slip soffit

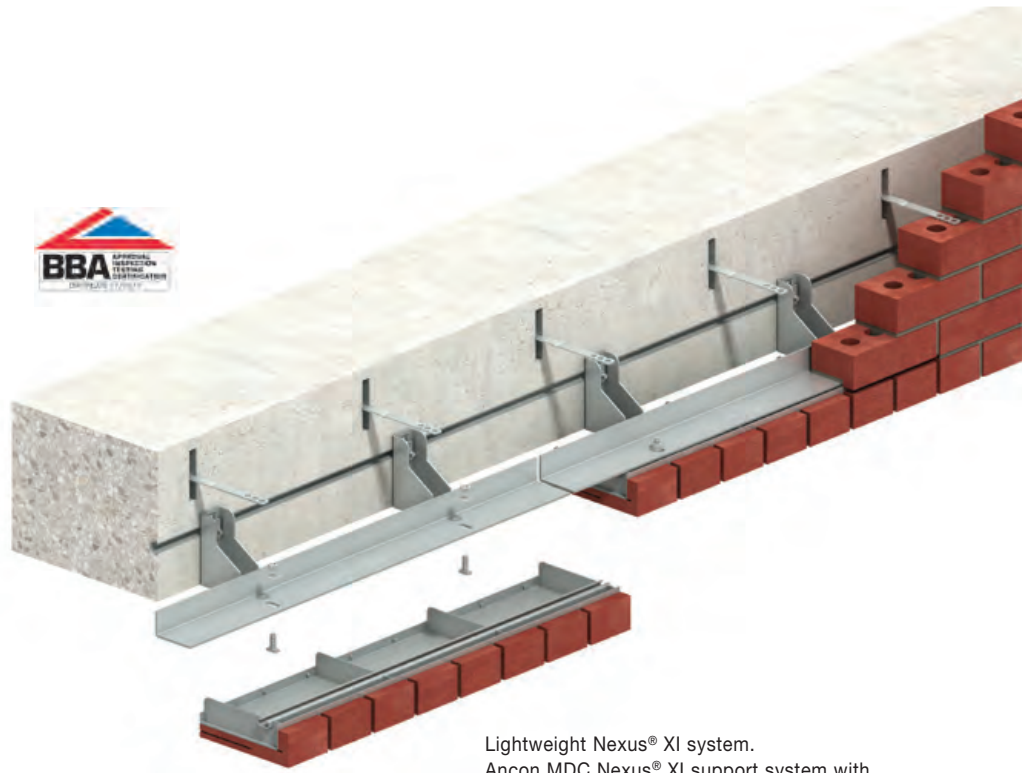

Lightweight Nexus® XI system.
Ancon MDC Nexus® XI support system with Nexus® XI brick-faced soffit from Ibstock-Kevington

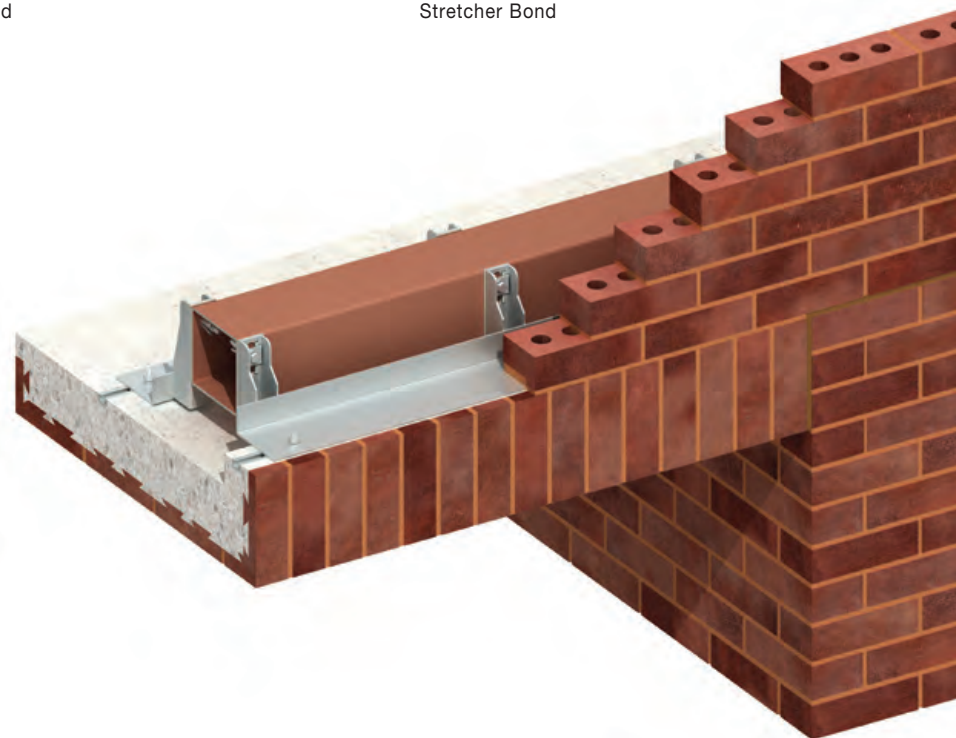

Masonry Support Systems & Lintels

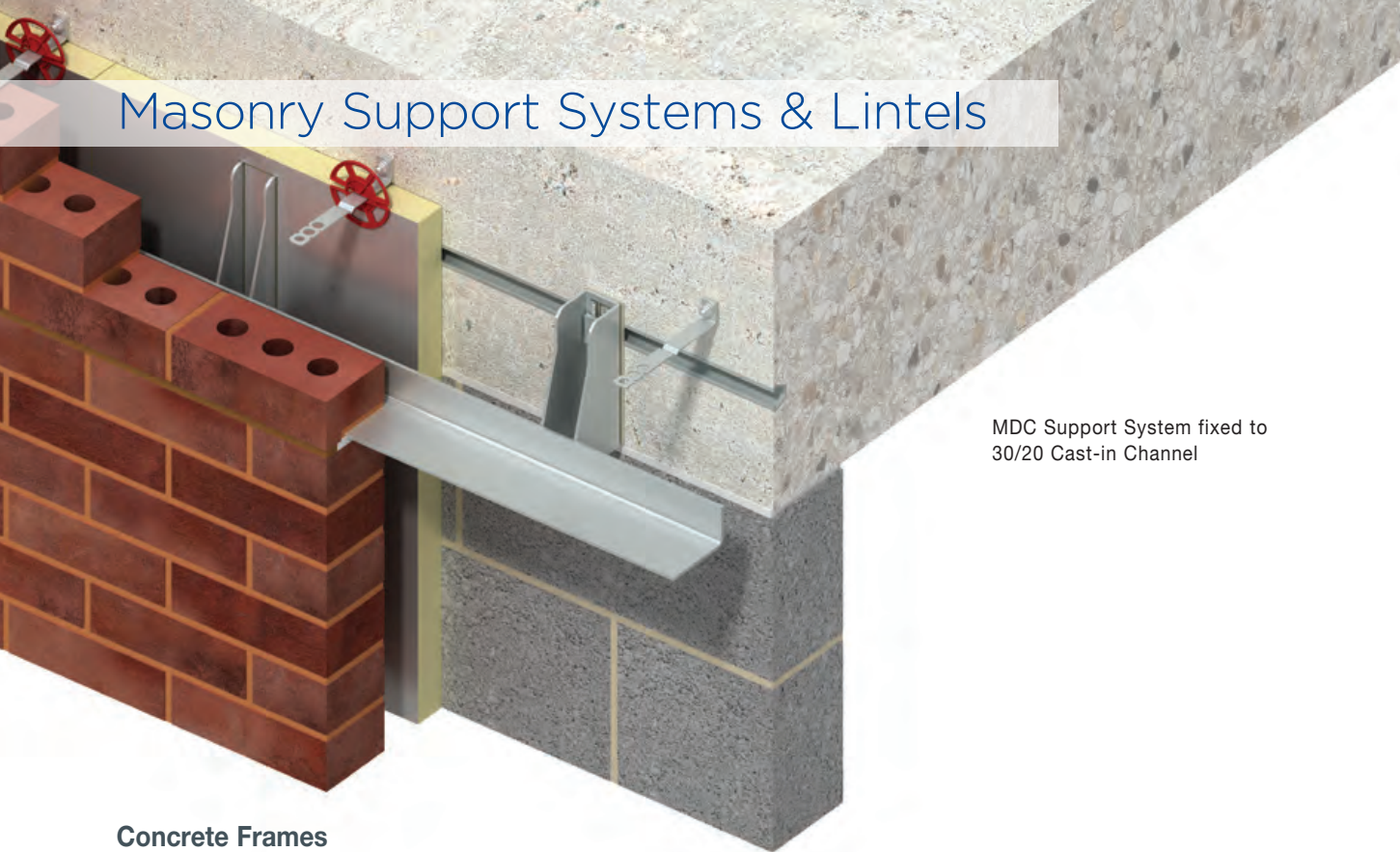

MDC Support System fixed to 30/20 Cast-in Channel

Concrete Frames

Ancon Masonry Support Systems are generally fixed to either Ancon 30/20 or 38/17 Channels cast into the edge of the concrete. For applications where particularly high loads are involved Ancon 40/25 Channel may need to be considered. The use of cast-in channels allows the support system to be fixed to the structure with 'T' bolts and moved along the line of the channel into the correct position. The slot in the back of the bracket allows vertical adjustment. This permits greater freedom in the positioning of the cast-in channel to avoid horizontal reinforcement.

As an alternative, Ancon Expansion or Resin Bolts can be used when cast-in channels have not been included in the edge beam.

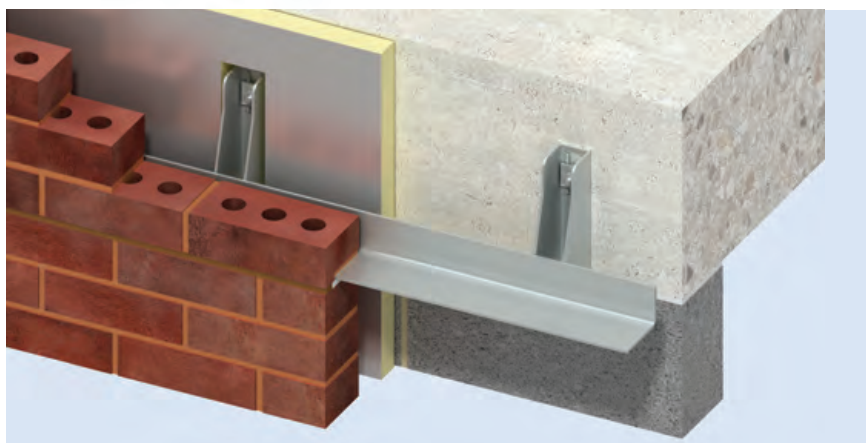

MDC Support System fixed with Single Expansion Bolts

Cross-Laminated Timber Frames

Leviat designs and manufactures Ancon masonry support systems for connecting to cross-laminated timber (CLT), working closely with specialist manufacturers of these frames and the associated fixings. An example system design is shown here. Contact our Technical Services Team for more information.

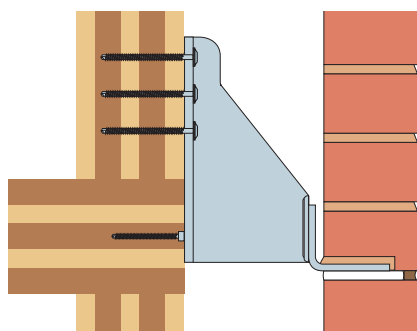

Ancon Masonry Support System Fixed to Cross-Laminated Timber

Steel Frames

Ancon Support Systems can be fixed directly to uncased structural steel frames. If excessive movement of the support system is to be avoided, the structural edge member must be designed to minimise deflections and accommodate the torsional forces created by the eccentric load from the brickwork. The fixing positions can usually be at constant centres to simplify the fabrication of the steelwork. For cavities larger than 75mm there may be a requirement for additional fixings near external corners.

When fixing any Ancon System other than AnconOptima to steel edge beam stiffeners, horizontal slots should be provided to allow lateral tolerance.

Where welded masonry support systems are fixed to hollow section beams, the site-drilling of holes is required for the fixings, during the masonry support installation procedure. Ancon Support Systems can be fixed using Ancon Steelgrip fixings. These fixings are designed for use where access is only available from one side.

Ancon CombiDeck (see pages 18 and 19) can replace the edge trim of metal deck shuttering and allow the Support System to be fixed directly to the face of the concrete floor.

As an alternative for higher loading conditions the Ancon MDC/TC Top Cleat System can be employed to fix directly to the top of the composite deck using expansion bolts.

Bi-metallic Contact

Corrosion of the steel frame may be slightly increased where there is direct contact with stainless steel in a damp environment. This will not affect the stainless steel and can be avoided by isolating the two dissimilar metals. This can be achieved by painting the contact area or by incorporating a separating membrane that can be supplied with the Ancon Support System. For further information see pages 6-7.

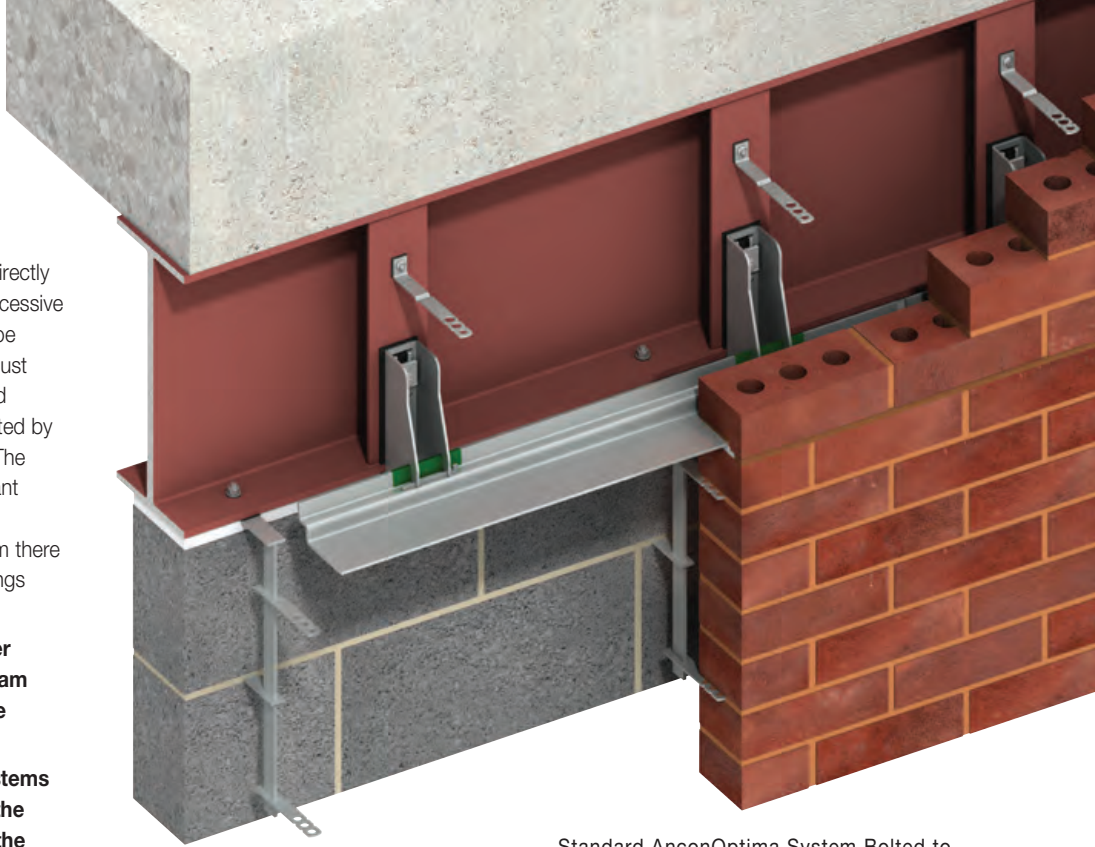

Standard AnconOptima System Bolted to Steel Edge Beam Stiffeners

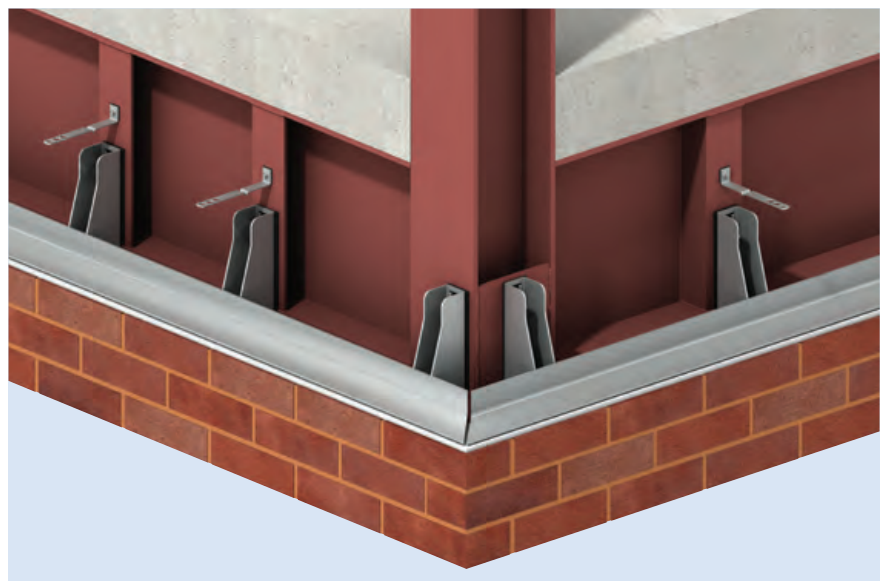

MDC Support System Bolted to Steel Edge Beam Stiffeners and a Corner Column

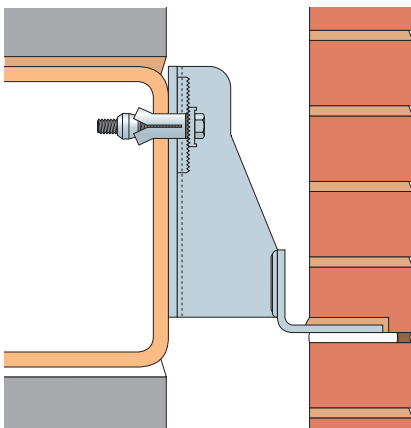

MDC Support System fixed to face of RHS using Ancon Steelgrip

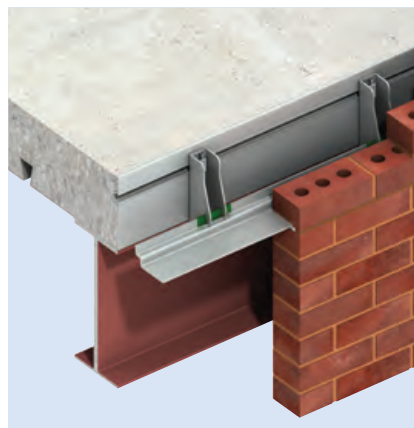

AnconOptima Support System Fixed to CombiDeck Edge Trim

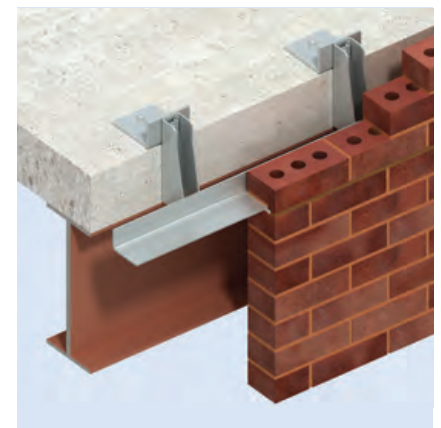

Ancon MDC/TC Top Cleat System

Masonry Support Systems & Lintels



Corner Detail Showing Fixing Straps Between CombiDeck and Metal Deck Shuttering

Ancon CombiDeck

Ancon CombiDeck has been developed for use with the permanent metal deck shuttering of steel framed structures. CombiDeck edge support is supplied with an integral channel section that accepts standard Ancon 'T' Head Bolts.

CombiDeck is manufactured in zinc coated mild steel with a stainless steel or galvanised steel channel. Alternatively the complete assembly can be manufactured in stainless steel.

It is supplied in standard three metre lengths in a variety of heights to suit the floor thickness. Corner assemblies and special units are available to suit particular applications.

The stainless steel channel welded into the edge support will usually be Ancon 30/20, positioned 55mm below the top.

The thickness of the floor slab will determine the capacity of the support system. A 130mm thick slab will limit the height of single skin brickwork to 4 metres. Thicker slabs will permit more masonry to be supported. Ancon CombiDeck does not require special reinforcement details providing the slab includes at least the equivalent of H8 Shape13 bars at a maximum of 150mm centres.

Design Variations

Most Ancon Support Systems can be used with CombiDeck.

Welded CombiDeck corner units are available for external corners, where it is not possible to fix directly to a corner column.

Adjustment

The adjustment provided by Ancon CombiDeck is identical to the use of cast-in channels. The serrated and slotted face of an Ancon bracket allows for vertical adjustment. The built-in channel will provide virtually unlimited horizontal adjustment. Shims can be included between the bracket and the frame up to a maximum thickness of the outside diameter of the fixing bolt or 16mm, whichever is less. As an alternative, Ancon Extension Plates can be used to increase the bearing for the brickwork (page 13).

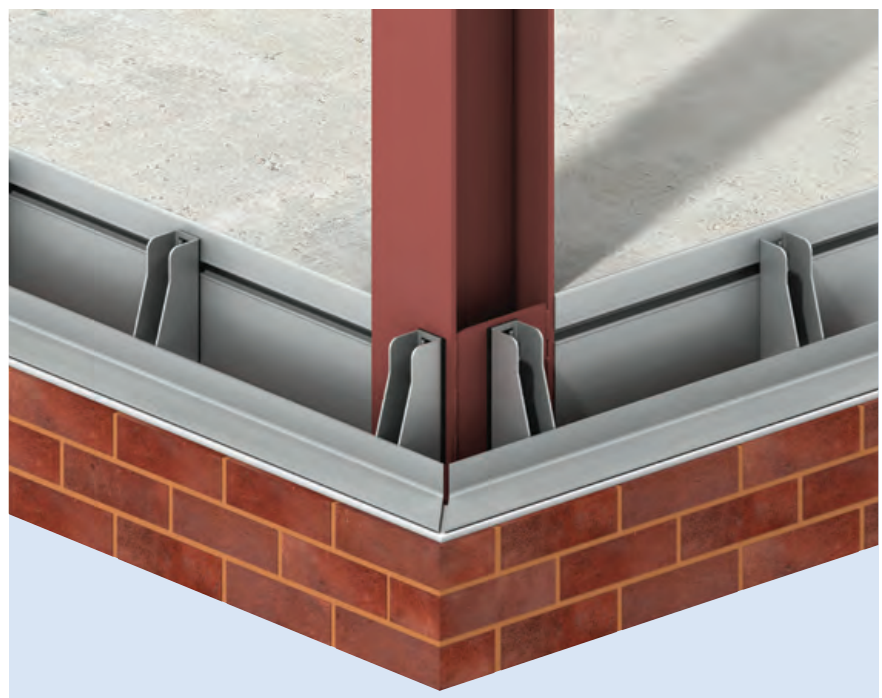

MDC Support System Bolted to CombiDeck and a Corner Column

Details for Specification and Ordering

Ancon MDC Systems and non-standard AnconOptima Systems are tailored to suit each project, based on the cavity size at the support and the masonry load to be supported. We will design an economical configuration of channel, bracket and angle.

For applications using CombiDeck the specification is as follows:-

System / CD / type / cavity / unfactored masonry load
 e.g. MDC / CD / R / 75 / 5.6

We will design an Ancon MDC System to fix to CombiDeck with a reversed angle to suit a 75mm cavity and carry 5.6 kN/metre run of masonry (unfactored).

References

MDC/CD Standard CombiDeck system

MDC/CD/R CombiDeck system with reversed angle

The CombiDeck edge support is specified as follows:-

CombiDeck / channel size / height of edge
 e.g. CombiDeck / 30 / 140

This will have a 30/20 channel and will suit a floor with a depth of 140mm.

Fixing CombiDeck to Steelwork

The standard edge trim used with metal deck permanent shuttering is designed to retain the wet concrete during construction of the floor. Ancon CombiDeck also has to support the external brickwork. It is therefore very important that the outside edge of the CombiDeck remains vertical. The installation procedure and allowable overhang may be different to those of the edge trim which CombiDeck replaces.

The CombiDeck should be fixed to the steelwork or metal deck at 300mm maximum centres.

Fixing straps are supplied to restrain the top edge of the CombiDeck. These will be positioned within 100mm of each butt joint or end and at centres not exceeding 450mm. The straps are supplied in 1.5 metre lengths for cutting and bending on site.

The outer edge of the CombiDeck can extend beyond the steelwork up to a maximum distance of 100mm. If a greater distance is required, both the metal deck and the CombiDeck will need to be propped.

A minimum of 125mm should be left between the outer edge of the CombiDeck and the metal deck to allow sufficient space for the channel anchors and the local reinforcement. Where the decking is at 90° to the CombiDeck, the open troughs must be filled to retain the wet concrete. The butt joints between lengths of CombiDeck should be taped to prevent concrete leakage.

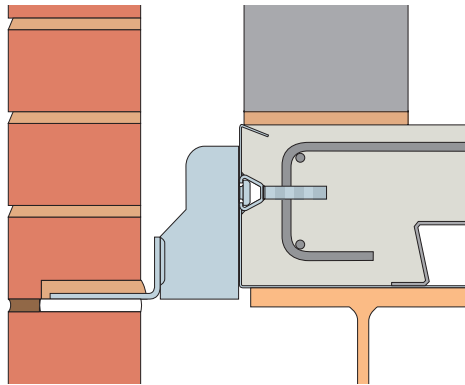

Typical Reinforcement Detail Behind CombiDeck

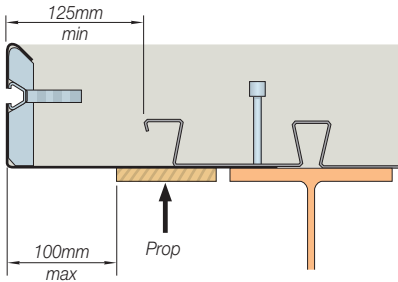
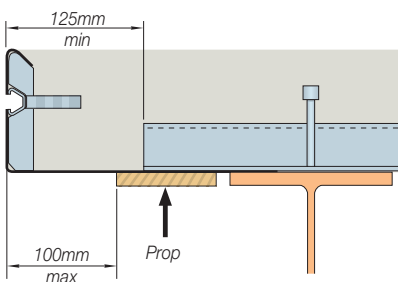
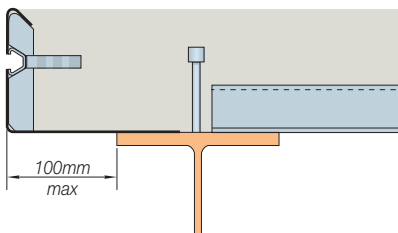

Maximum Overhang of CombiDeck

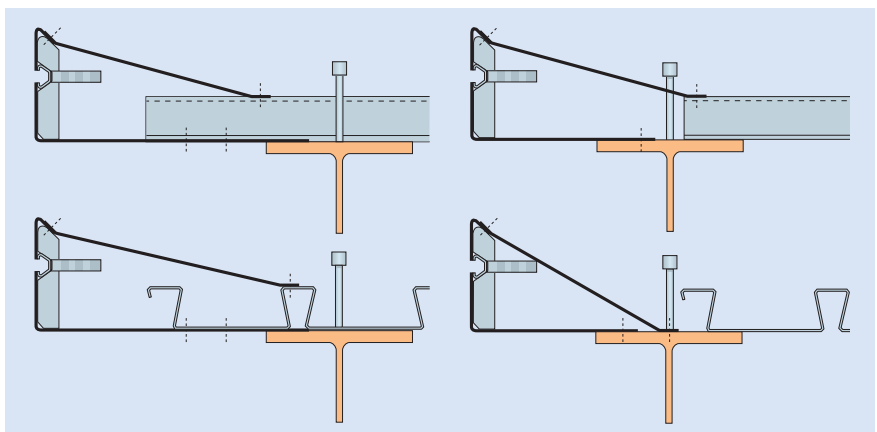

Typical Details of Fixing Strap Connections

Masonry Support Systems & Lintels

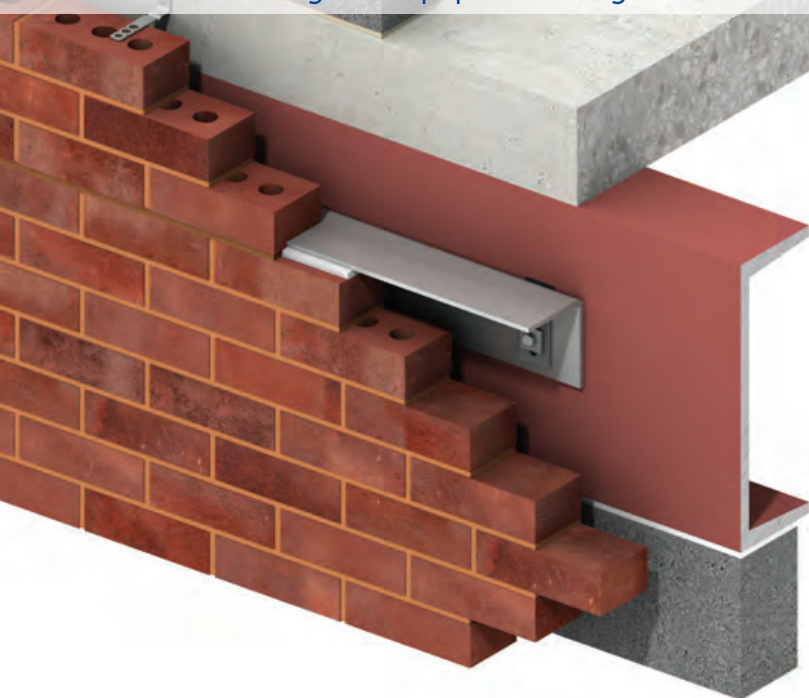

CFA/I Support System Fixed to Structural Steel Edge Beam

Ancon CFA Continuous Angle Support System

Ancon CFA Systems can carry over 8 metres of brickwork and accommodate various cavity widths. For many applications, particularly where large cavities are involved, the Ancon MDC Support System may prove to be a more economical solution. Continuous angles are more suitable for applications where cavities are small or there is a requirement for the cavity to be closed at the support position. The angles are cold formed and will normally be supplied in lengths of up to 2 metres.



Design Variations

In addition to variations in angle size and thickness, an inverted version, the CFA/I, has the support leg at the top and the fixing slots positioned closer to the corner of the angle.

Steel Frames

Ancon CFA Support Systems can be fixed directly to uncased structural steel frames. Universal beams will require an angle to be welded between the flanges at each bracket position. **Horizontal slots should always be provided in the steel edge beam to allow lateral tolerance with the exception of hollow section edge beams. Hollow section edge beams should be site-drilled with holes for the fixings during the masonry support installation procedure.**

The angle will have vertical slots with serrated pads welded to the angle.

The structural edge member must be designed to minimise deflections and accommodate the torsional forces created by the eccentric load from the brickwork, if excessive movement of the support system is to be avoided.

Concrete Frames

The CFA System can be fixed to cast-in channels or with expansion bolts. The support angle will either be provided with horizontal slots to suit AnconLock Toothed Channels or with vertical slots and serrated pads to suit continuous channels cast horizontally and post-installed anchors. For further information see the Ancon Channel and Bolt Fixings brochure.

Adjustment

Adjustment is provided in orthogonal directions to allow for tolerance in the structural frame. Vertical slots in the angle with serrated pads allow $\pm 20\text{mm}$ adjustment. Horizontal adjustment is virtually unlimited when fixing to a continuous cast-in channel and will depend on the length of the slotted holes in the edge member when fixing to steelwork.

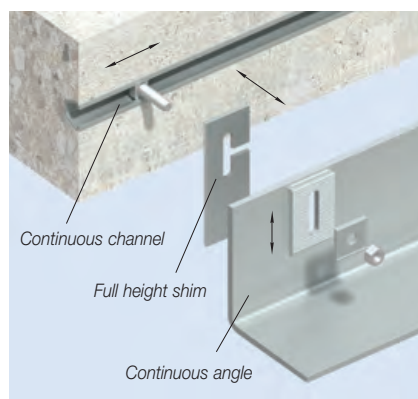

The serrated lips of the AnconLock Channel permit a vertical adjustment of up to $\pm 28\text{mm}$. Slotted holes ($18 \times 60\text{mm}$) in the angle allow horizontal adjustment of $\pm 22\text{mm}$. Shims can be included between the bracket and the frame up to a maximum thickness of the outside diameter of the fixing bolt, or 16mm whichever is less.

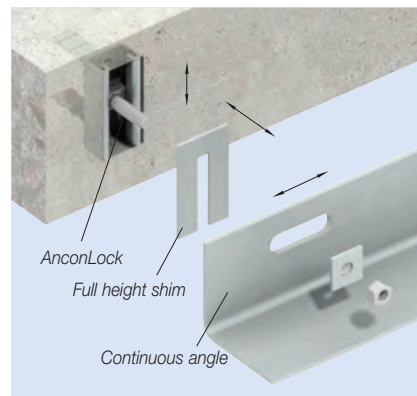

Bi-metallic Contact

Corrosion of the steel frame may be slightly increased where there is direct contact with stainless steel in a damp environment. This will not affect the stainless steel and can be avoided by isolating the two dissimilar metals. This can be achieved by painting the contact area or by incorporating a separating membrane that can be supplied with the Ancon CFA Support System. For further information see pages 6-7.

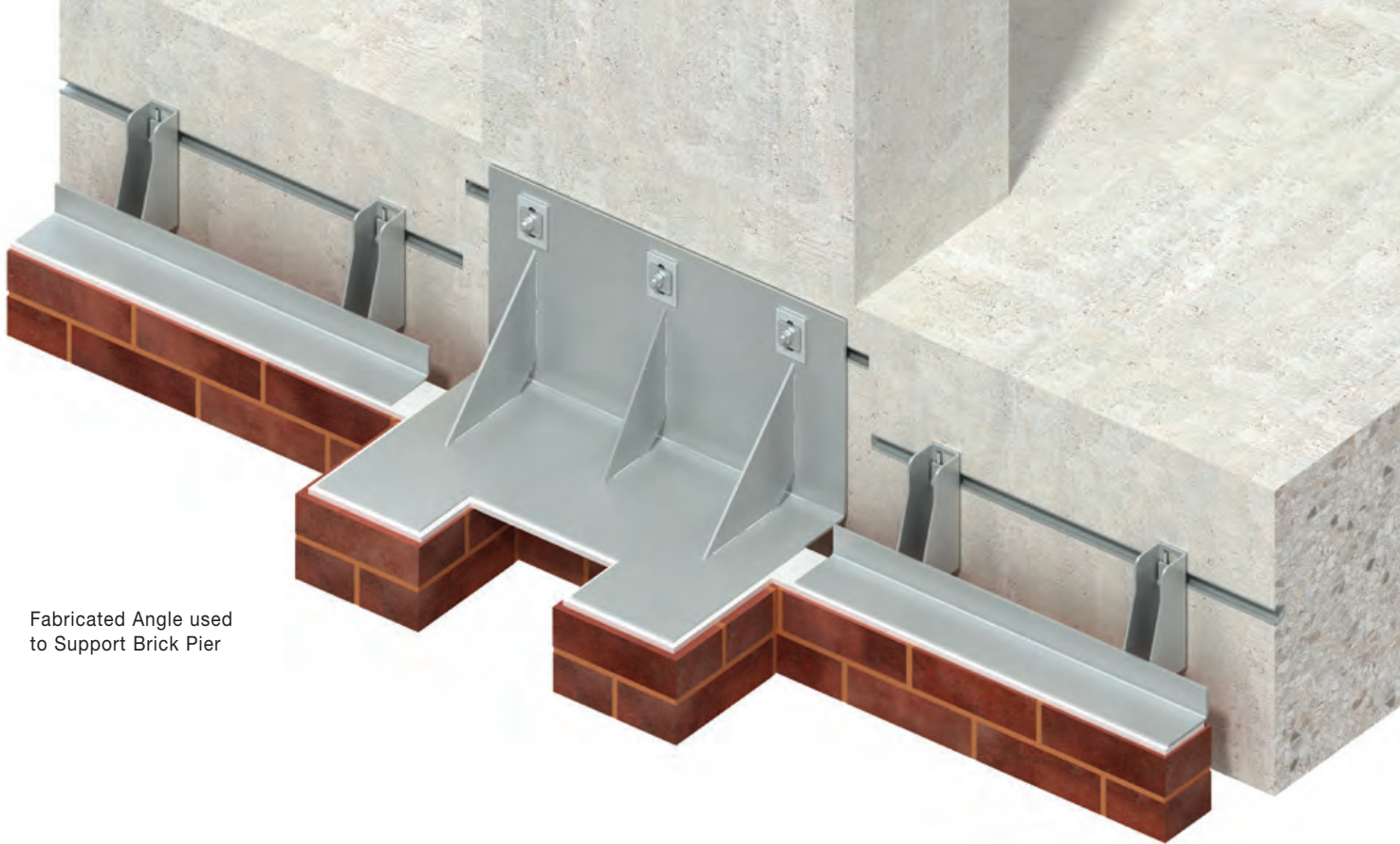

Fabricated Angle used to Support Brick Pier

Setting Out

We can provide drawings showing the location of the fixings (cast-in channels for concrete frames, bolt positions for steel frames). Angle units will be referenced and scheduled and all details submitted for approval before manufacture.

Fabricated Angles

Many features will need special design attention, especially if double skin brickwork is to be supported. Fabricated angles with stiffeners, used in conjunction with the Ancon MDC System for adjacent single skin brickwork, is often the best solution.

Curved Masonry

Curved angles can be supplied for arches or other applications. Where masonry is curved on plan, we can provide either curved angles, individual brackets (pages 22-23) or an MDC System (pages 12-14) in short angle lengths.

Details for Specification and Ordering

Ancon CFA Systems are tailored to suit each job, based on the cavity size at the support and the load to be carried. We will design the most economical system. Specification is as follows:-

CFA / type / cavity / unfactored masonry load
e.g. CFA / 1 / 50 / 6.0

We will design a system with an inverted angle to suit a 50mm cavity and carry 6.0kN/metre load (unfactored).



References

CFA Standard system
CFA/I Inverted system

Some applications demand that the support leg is below the soffit of the structure. Where this is no more than 75mm, this can be specified as a suffix to the standard reference by **D drop**.

CFA / cavity / unfactored masonry load / drop
e.g. CFA / 50 / 5.6 / D 50

We will design a standard system to suit a 50mm cavity, carry 5.6kN/m (unfactored), with an angle drop of 50mm.

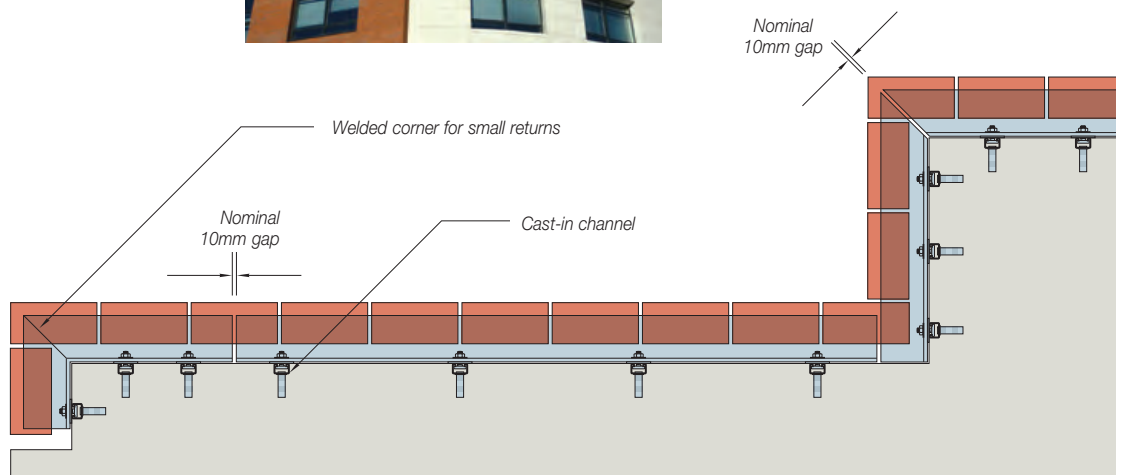

Typical Layout of CFA Support System

Masonry Support Systems & Lintels

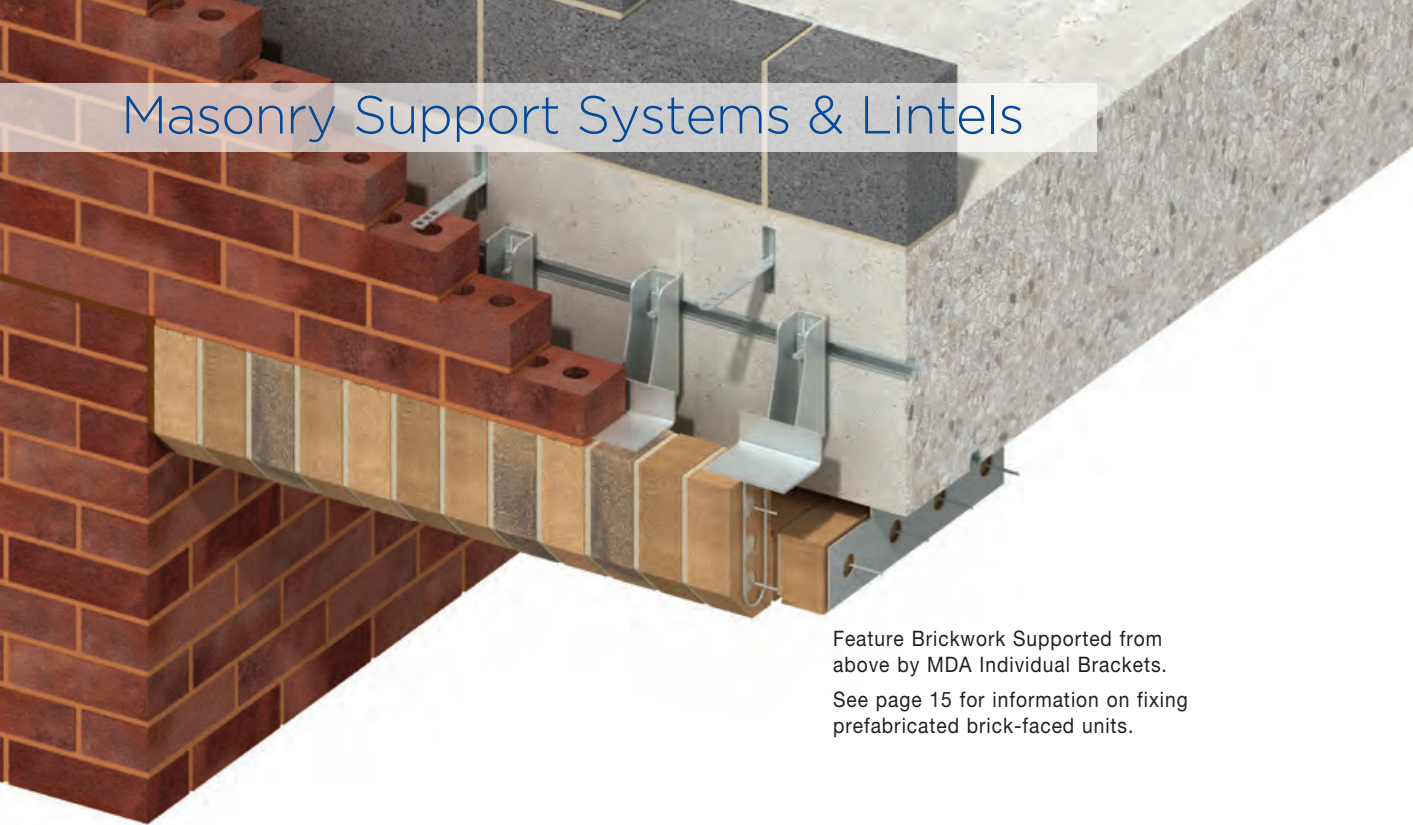

Feature Brickwork Supported from above by MDA Individual Brackets.

See page 15 for information on fixing prefabricated brick-faced units.

Ancon Individual Bracket Support System

Like the MDC continuous angle support system, the Ancon MDA Individual Bracket Support System is designed and manufactured to meet the specific cavity width and masonry load of an application. Brackets at 225mm centres will carry 8 metres of brickwork.

The system comprises individual brackets positioned at each perpend, bolted back to the structural frame.

Design Variations

Two applications for individual brackets are for the support of soldier courses from above, and for the support of non-structural arched brickwork. Both these applications involve individual brackets at 225mm centres that have stirrups welded to the underside. Stitching rods span the stirrups and support the three bricks between the brackets.

Ancon Soffit Angles are used in conjunction with the MDA System to extend the support of soffit brickwork. These are usually spaced at 225mm centres and fixed to Ancon 28/15 Cast-in Channel.

Adjustment

Adjustment is provided in every direction to allow for tolerance in the structural frame. The serrated and slotted face of the bracket allows for vertical adjustment. Cast-in channel will provide virtually unlimited horizontal adjustment. Shims can be included between the bracket and the frame up to a maximum thickness of the outside diameter of the fixing bolt or 16mm, whichever is less.



© DUJPE Photography

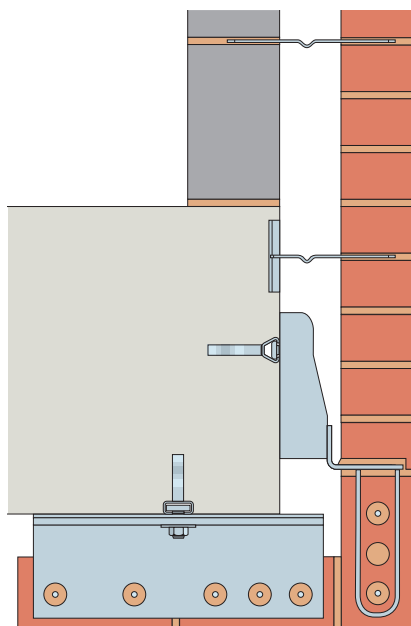

Soffit Support using the MDA System and Soffit Angle

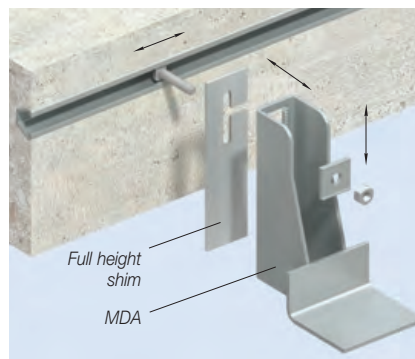

Adjustment of Individual Bracket Support System

Curved Brickwork

The Ancon MDA system is ideal for supporting brickwork that is curved on plan. When fixing to concrete, Ancon 30/20 or 38/17 channel can be supplied curved to suit the radius or expansion bolts can be used.

Setting Out

We can provide drawings showing the location of the cast-in channels. Brackets will be referenced and scheduled, and all details submitted for approval before manufacture.

Details for Specification and Ordering

Ancon Individual Brackets are available to suit most cavity sizes and can be specified as follows:-

MDA / cavity / unfactored masonry load

e.g. MDA / 75 / 8.0

We will design an Ancon MDA System to suit a 75mm cavity and carry 8.0 kN/metre load (unfactored).

Support to brickwork around external corners may involve special details.

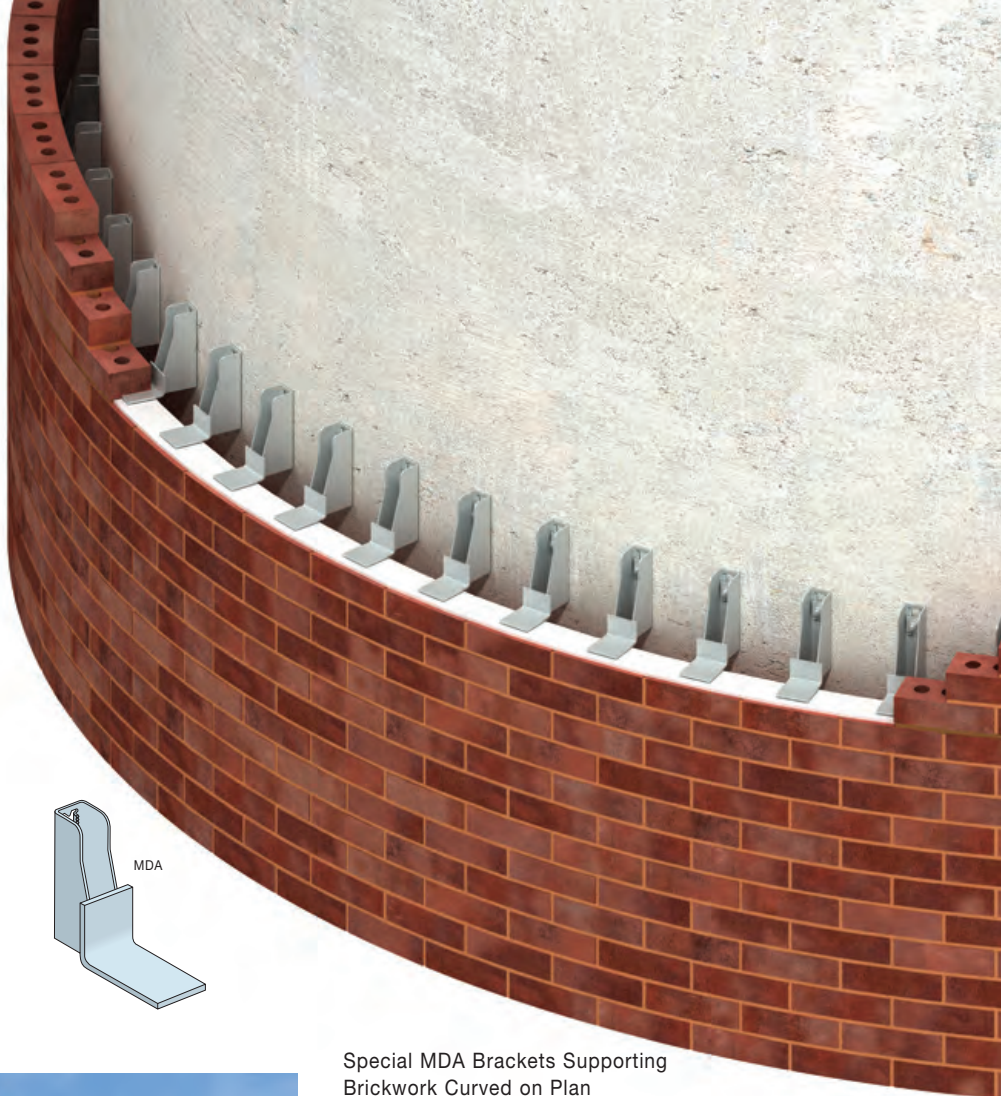
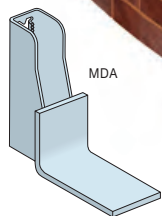

Special MDA Brackets Supporting Brickwork Curved on Plan



© Hazle McCormack Young



© Hazle McCormack Young

Masonry Support Systems & Lintels

Stonework Support

Stone cladding is often a combination of large individually sized stones. These can sometimes vary in thickness and may include cornice or other stones that stand out from the general line of the cladding. Support for the stonework will usually be positioned over the horizontal movement joint at each floor level and over openings.

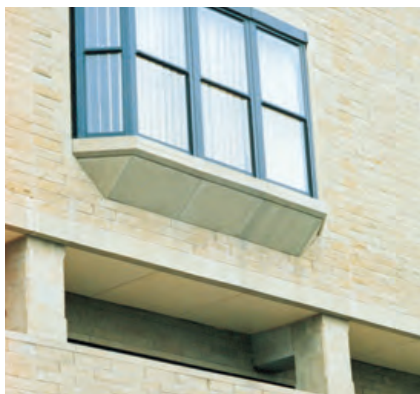

The most efficient method is for individual corbel supports to be positioned at the vertical joint between two adjacent stones. As an alternative, two smaller supports can be located near each end of each stone. The support of cornice and other particularly large stones will need special attention.



Individual MDC/SC Stonework Support Brackets

Design Considerations

The design of stone cladding should be in accordance with BS 8298 : 2010 Code of practice for the design and installation of natural stone cladding and lining.

The minimum bearing at the support is generally 50% of the thickness of the stone. A single support carrying two stones should be at least 75mm long. Where individual supports are used, these should be at least 50mm long.

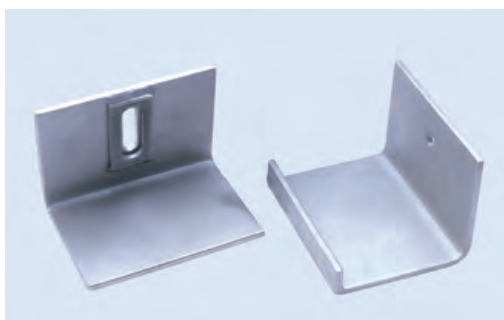
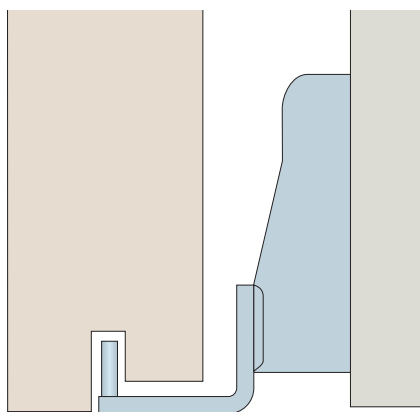

Individual CFA/SC and CFA/SL Stonework Corbel Angles

Ancon CFA/S Stonework Supports

CFA/S Corbel Angles

These are individual angles that accommodate a fixing bolt in the vertical leg. The dimensions are chosen to suit the application. The angles can also be supplied with a lip or dowels to restrain the base of each stone (Ref CFA/SL or CFA/SD).

CFA/SC Corbel Angles

These are similar to the CFA/S, but the bottom leg is inclined at 15° to provide restraint where the support has to be positioned above the base of the stone.

Ancon Corbel Angles are designed to suit each application. The table shows examples of CFA/S and CFA/SC supports. Please contact our Technical Services Team to discuss specific requirements.



Individual CFA/SC Stonework Corbel Angle

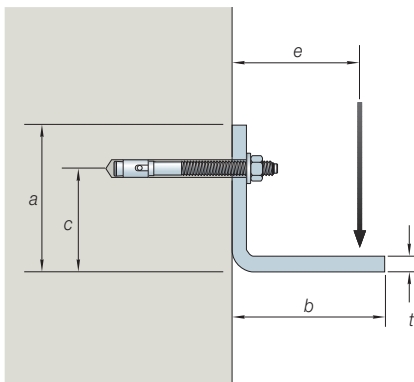

Typical Sizes for CFA/S and CFA/SC Supports 150mm Long

Load Position e (mm)	Thickness t (mm)	Fixing Height c (mm)	Overall Height a (mm)	Outstand b (mm)	Design Resistance (kN)
60	8	70	100	73	4.6
	10	70	100	73	7.3
80	8	70	100	93	3.2
	10	70	100	93	5.3
100	12	100	130	93	7.8
	8	70	100	113	2.0
120	10	70	100	113	3.6
	12	100	130	113	5.4
140	12	100	130	133	3.7
	15	120	150	133	6.2
140	15	120	150	153	4.5

Notes: Fixing requirements may vary depending on the design load and substrate type. Please contact us for guidance. The above values should be used in conjunction with the appropriate Eurocode safety factor of 1.35 (γ_G)

References

- CFA/S Standard corbel angle
- CFA/SC Corbel with angle leg inclined 15°
- CFA/SD Corbel angle with dowels
- CFA/SL Corbel angle with lip



CFA/S



CFA/SD

Masonry Support Systems & Lintels

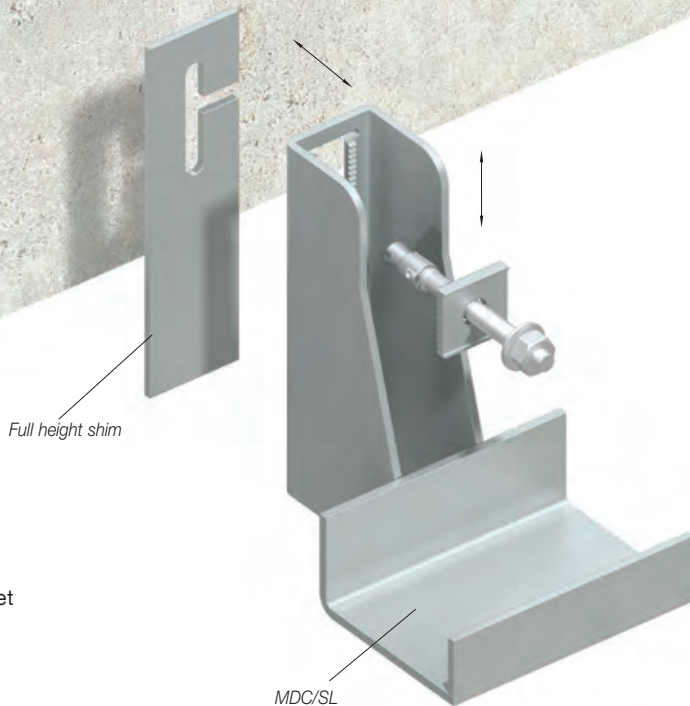

Adjustment of MDC/SL Bracket



Individual MDC/SD Stonework Support Bracket

Ancon MDC/S Stonework Supports

Ancon MDC/S Stonework Supports are based on the MDC masonry support system. The bracket height and depth are varied to suit the cavity size and the loadings. The dimensions of the angle are selected to suit the stonework to be supported.



Design Variations

The MDC/S Stonework Support can be supplied in a variety of configurations to suit the particular application.

Ancon MDC/SD has a dowel to restrain the base of each stone, MDC/SC has the bottom leg of the angle inclined at 15° to provide restraint where the support has to be positioned above the base of the stone.

Adjustment

The serrated and slotted face of the MDC/S bracket allows for vertical adjustment. Cast-in channel will provide horizontal adjustment, but because fixing positions can be difficult to predetermine, expansion bolts are often used. Shims can be included between the bracket and the frame up to a maximum thickness of the outside diameter of the fixing bolt, or 16mm, whichever is less.

Details for Specification and Ordering

Ancon Stonework Supports are generally designed to suit specific contracts. Our technical staff will be pleased to discuss the most appropriate support system. Stonework supports are specified as follows:-

MDC / type / cavity / stone width / unfactored load

e.g. MDC / SD / 100 / 75 / 4

We will design individual MDC/SD supports with dowels to suit 75mm thick stone with a 100mm cavity behind. Each bracket will support a load of 4kN (unfactored).

References

- | | |
|------------|-------------------------------------|
| MDC/S | Standard MDC Stonework Bracket |
| MDC/S/BK03 | With Thermal Break |
| MDC/SC | Bracket with angle leg inclined 15° |
| MDC/SD | Bracket with dowels |
| MDC/SL | Bracket with lip |

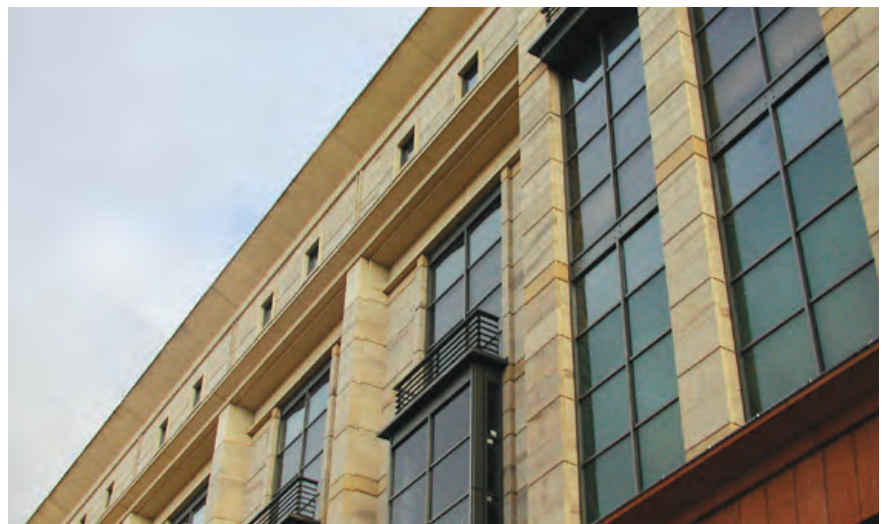



SSB Stonework Support Bracket

Ancon SSB Support Brackets

The Ancon SSB Bracket supports and restrains stonework with a facing thickness of between 25mm and 40mm. They can be positioned in either the vertical or the horizontal joints and allow adjustment without the need for shims.

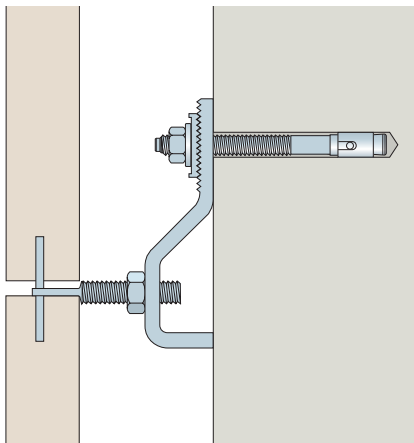

SSB Stonework Support Bracket

Ancon SSB Support Brackets

Reference	Spade Bolt Reference	Facing Thickness (mm)	Cavity Size (mm) for Max Adjustment	Adjustment +/- (mm)	Fixing Height (mm)
SSB-1	M12 x 58	25	50	8	105
	M12 x 58	30	48	8	105
	M12 x 105	40	88	10	105
SSB-1a	M12 x 58	25	60	8	105
	M12 x 58	30	58	8	105
SSB-2	M12 x 105	40	88	10	105
	M16 x 58	25	63	5	139
	M16 x 58	30	60	5	139
SSB-2a	M16 x 115	40	98	10	139
	M16 x 58	25	78	6	139
	M16 x 58	30	75	5	139
SSB-2c	M16 x 115	40	98	10	139
	M16 x 94	25	100	10	139
	M16 x 94	30	100	10	139
	M16 x 115	40	100	10	139

Notes: Where dead load is applied, the Ancon SSB Support Brackets should be positioned in the horizontal joints.

SSB - Design Resistance Chart (All Loads Factored)

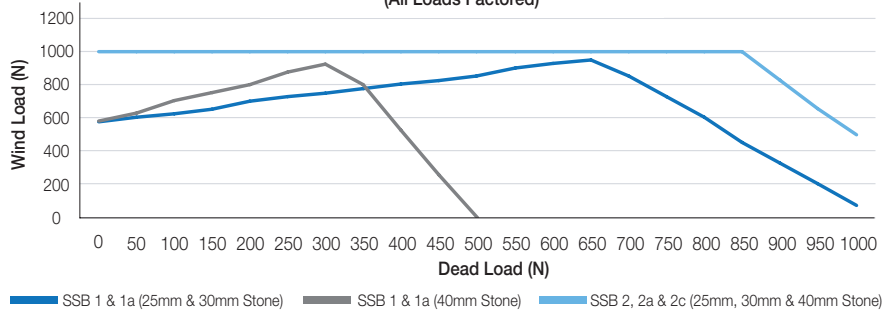

Ancon Soffit Fixing

Ancon soffit fixings are a simple and secure method of fixing thin facing slabs. This heavy duty support and restraint fixing comprises a stainless steel head and bolt and is quick and easy to install. The disc fixing is fully adjustable and able to support a safe working load of 600N in tension.

The stone should be checked to ensure it is capable of withstanding the localised bearing stress under the disc.

Ref.	Torque	Length	Disc size	Hole size
SF150	15Nm	150mm	50 x 5mm	12 x 85mm

Note: Other sizes can be manufactured on request.



Soffit Fixings

Ancon soffit fixings are suitable for fixing to concrete strength classes C20/25 to C50/60, cracked or un-cracked.

Masonry Support Systems & Lintels

Lintels

Leviat manufactures a complete range of Ancon stainless steel lintels. Our cavity wall lintels are designed to suit the loading conditions found in the majority of residential and commercial buildings. Our comprehensive standard range consists of:

- Cavity Wall Lintels
- Channel Lintels
- Solid Wall Lintels
- Single Leaf Lintels
- Timber Frame Lintels
- Box Lintels

Technical Assistance

Our Technical Services Team is available to advise on specification, design, installation and structural loading conditions.

Online Product Selector

Visit www.ancon.co.uk to use the online Ancon Lintel Product Selector. Answer a series of simple questions concerning your application and the most suitable lintel will be referenced.

Custom Lintels

In order to meet the requirements of today's challenging industry, Leviat designs and manufactures special Ancon stainless steel lintels for applications where standard lintels are unsuitable.

Solutions can be supplied for complex features such as corbels and other architectural details.

Special cranked, bay, corner and cantilevered corners are available in addition to the following arch shapes:

- Segmental arch
- Semi-circular arch
- Apex arch
- Gothic arch
- Flat top arch
- Double arch

Our Technical Services Team will offer advice on the most appropriate lintel or alternative method of supporting masonry.

Like all of our bespoke fabrication work, our custom-designed lintels carry CE marking to BS EN 1090-1 confirming design to EN 1993 (Eurocode 3) and manufacture at facilities externally audited by an approved body. See page 2 for details or visit www.ancon.co.uk/CE.

The following information will aid the design of a custom lintel and if available should be supplied with your enquiry.

- Wall construction: outer leaf, inner leaf and cavity size.
- Clear span of opening.
- Bearings available (if less than 225mm).
- Radius or rise of arch and angles for apex/ cranked and corner lintels.

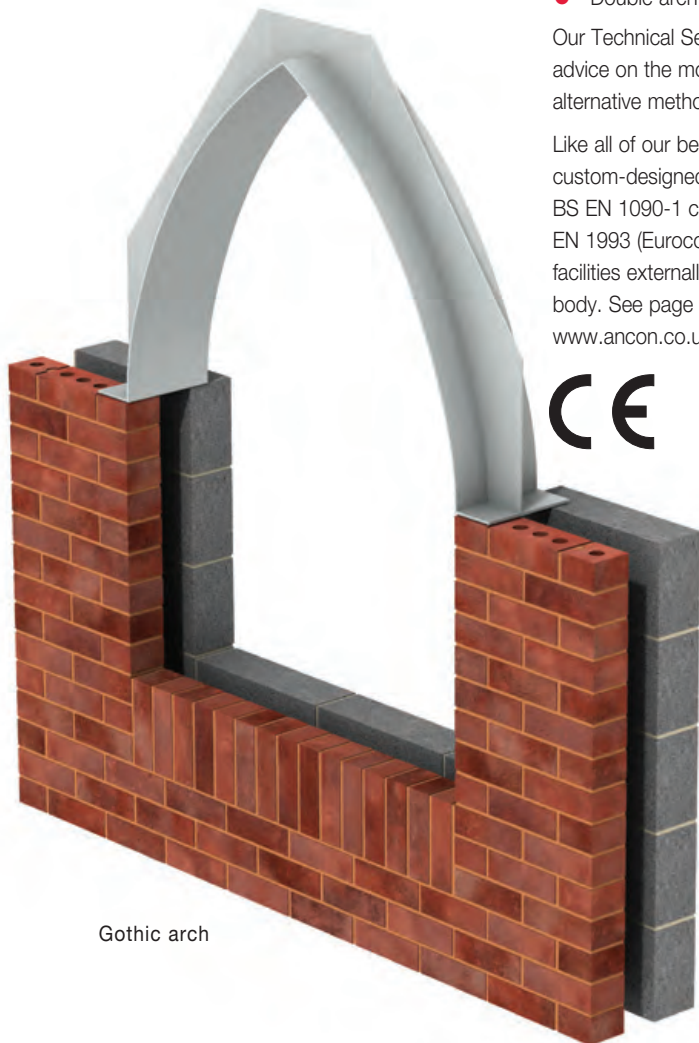

Gothic arch

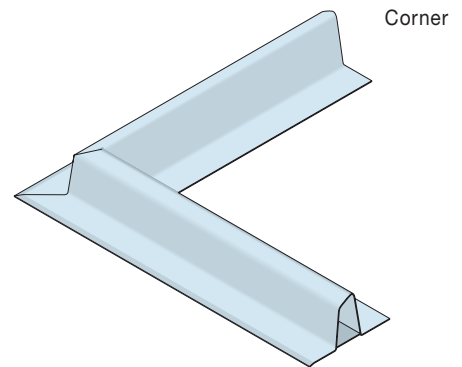

Corner

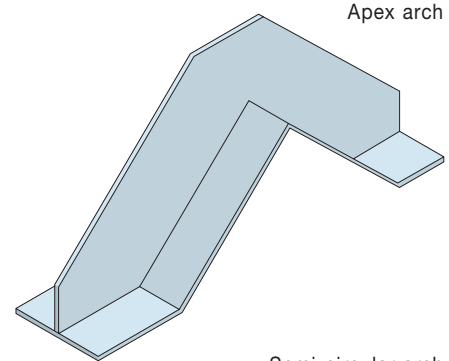

Apex arch

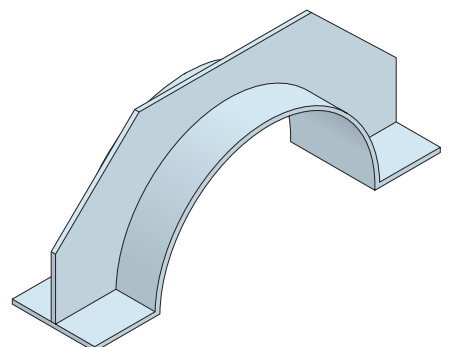

Semi-circular arch

SUX Heavy Duty
Cavity Wall Lintel

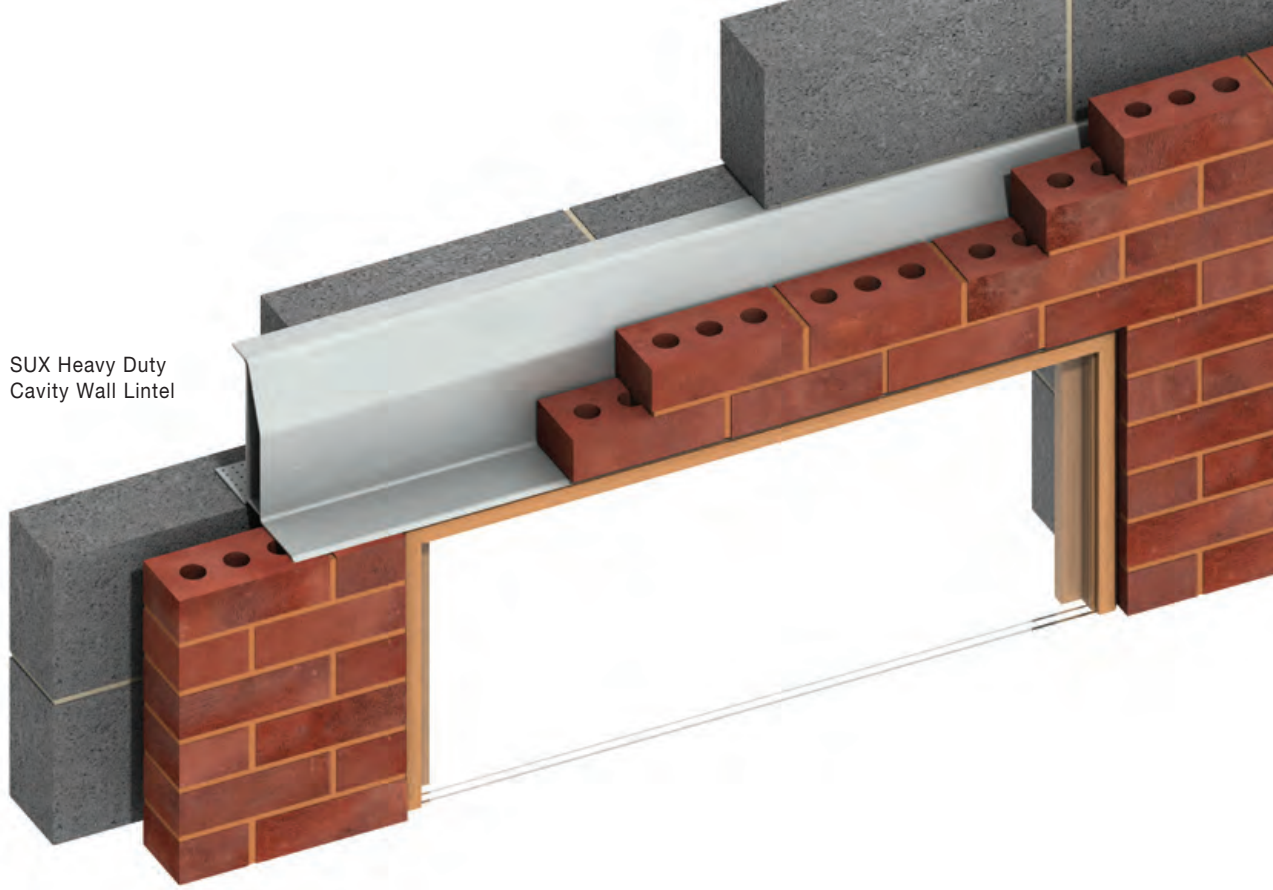

Corrosion Resistance

All Ancon Lintels are manufactured from Austenitic stainless steel and will not require any further corrosion protection.

Thermal Performance

The thermal transmittance, i.e. 'U' value, of any wall construction depends on the thermal characteristics of the individual components being used. The design of Ancon Cavity Wall Lintels is such that it allows for continuity of construction down to window head level.

Where required, Cavity Wall Lintels are supplied insulated with either CFC-free, high density polystyrene or non-combustible class A1 mineral wool. Contact us for more information.

Structural Performance

The safe working loads are derived by calculation and supported by tests to establish their validity.

Load Ratios

The safe working loads for Cavity Wall Lintels in the tables on pages 30 and 31 are for situations where the total distributed load on the lintel is shared between the inner and outer leaves in ratios of between 1:1 and 3:1 respectively. For other load ratios, point loads or lintels carrying concrete floors, please contact our Technical Services Team.

Installation

The lintel should be firmly bedded in mortar with at least 150mm end bearing onto a full brick/block.

Please consult our Technical Team when using reduced bearings for revised capacities.

The front and back of the lintel must be level before proceeding and a separate dpc incorporated if required.

When installing Cavity Wall Lintels the inner and outer leaves should be raised together to avoid twisting the lintel; blocks should continue for the full length of the inner flange. Masonry should have a maximum overhang of 25mm and blockwork should be built as close as possible to the upstand. Point loads should be applied at least 150mm above lintel flanges.

Although the lintels have a drip edge on the external flange to shed moisture, good practice should be followed at the junction of the window head and lintel by sealing with a suitable mastic, thereby ensuring that driving rain does not penetrate.

Weep vents are generally required above lintels at a maximum of 450mm centres. Each opening should have at least two weep holes and stop ends are required to prevent moisture penetration.

Long spanning lintels and all single leaf lintels will require propping during installation to limit deflections.

CE Marking

Construction products which fall within the scope of a harmonised European Standard should carry CE marking under the Construction Products Regulation.

For lintels, the harmonised standard is BS EN 845-2. Look out for the CE logo on our lintel pages. For more information or to download a Declaration of Performance, please visit www.ancon.co.uk/CE.



Masonry Support Systems & Lintels

Cavity Wall Lintels

These are suitable for most domestic and commercial developments and framed structures. Perforations in the inner flange offer an integral plaster key. SH lintels require a separate dpc, while SU and SUX lintels act as a built-in dpc meaning any water penetrating into the cavity automatically transfers across the sloping face of the lintel and is disposed of externally.

When installing cavity wall lintels the inner and outer leaves should be raised together to avoid twisting the lintel; blocks should continue for the full length of the inner flange. Masonry should have a maximum overhang of 25mm and blockwork should be built as close as possible to the upstand. Point loads should be applied at least 150mm above lintel flanges.



Use of polystyrene insulated light duty lintels, referenced SH, is restricted to residential buildings up to a maximum height of 18 metres.

Other cavity wall lintels are insulated with non-combustible class A1 mineral wool on request. These lintels are suitable for residential (and other building types) of any height.

Cavity Wall Lintels for an inner leaf of 100-115mm

SH Light Duty Lintel

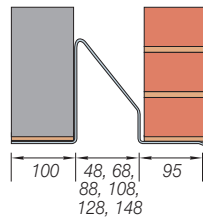

SU Medium Duty Lintel

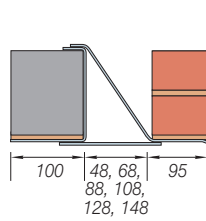

SUX Heavy Duty Lintel

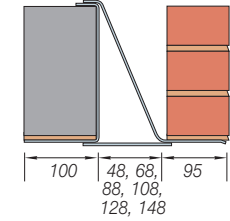

Cavity Wall Lintels for an inner leaf of 125-140mm

SH_E Light Duty Lintel

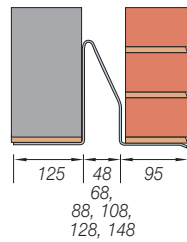

SU_E Medium Duty Lintel

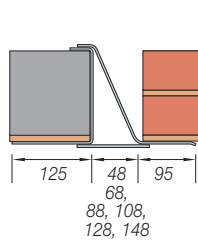

SUX_E Heavy Duty Lintel

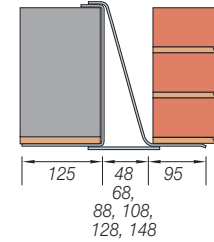

Cavity (mm)	Inner Leaf (mm)	Lintel Reference	Length (mm)	SWL (kN)	Nom. Height (mm)		
50-65	100-115	SH50	750-1800	18	140		
			1801-2100	20	160		
			2101-2400	22	180		
			2401-2700	26	220		
			2701-3600	26	220		
		SU50	900-1800	32	157		
			1801-2100	48	157		
			2101-2400	45	157		
			SUX50	900-2700	60	231	
				2701-3000	55	231	
		3001-3900		50	231		
		50-65	125-140	SH50E	750-1800	17	140
					1801-2400	20	180
					2401-3000	26	220
					SU50E	900-1800	32
1801-2100	48			157			
2101-2400	45			157			
SUX50E	900-2700			60	231		
	2701-3000			55	231		
	3001-3900			50	231		
					3901-4800	32	231

Cavity (mm)	Inner Leaf (mm)	Lintel Reference	Length (mm)	SWL (kN)	Nom. Height (mm)		
70-85	100-115	SH70	750-1800	18	140		
			1801-2100	20	160		
			2101-2400	22	180		
			2401-2700	26	220		
			2701-3600	26	220		
		SU70	900-1800	32	157		
			1801-2100	48	157		
			2101-2400	45	157		
			SUX70	900-2700	60	231	
				2701-3000	55	231	
		3001-3900		50	231		
		70-85	125-140	SH70E	3901-4800	32	231
					750-1800	17	140
					1801-2400	20	180
					2401-3000	26	220
SU70E	900-1800			32	157		
	1801-2100			48	157		
	2101-2400			45	157		
SUX70E	900-2700			60	231		
	2701-3000			55	231		
	3001-3900			50	231		
			3901-4800	32	231		

Cavity (mm)	Inner Leaf (mm)	Lintel Reference	Length (mm)	SWL (kN)	Nom. Height (mm)		
90-105	100-115	SH90	750-1800	18	140		
			1801-2100	20	160		
			2101-2400	22	180		
			2401-2700	26	220		
			2701-3600	26	220		
		SU90	900-1800	32	157		
			1801-2100	48	157		
			2101-2400	45	157		
		SUX90	900-2700	60	231		
			2701-3000	55	231		
			3001-3900	50	231		
			3901-4800	32	231		
90-105	125-140	SH90E	750-1800	17	140		
			1801-2400	20	180		
			2401-3000	26	220		
		SU90E	900-1800	32	157		
			1801-2100	48	157		
			2101-2400	45	157		
		SUX90E	900-2700	60	231		
			2701-3000	55	231		
			3001-3900	50	231		
					3901-4800	32	231

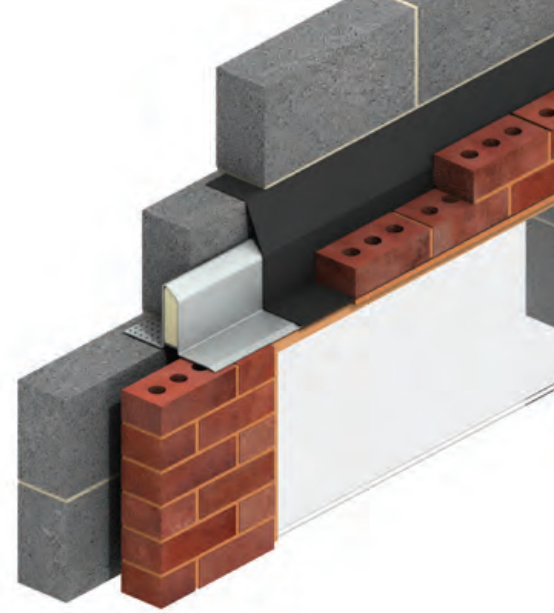

Cavity (mm)	Inner Leaf (mm)	Lintel Reference	Length (mm)	SWL (kN)	Nom. Height (mm)
110-125	100-115	SH110	750-1500	15	140
			1501-1800	17	140
			1801-2100	20	160
			2101-3600	26	220
		SU110	900-1800	32	157
			1801-2100	48	157
			2101-2400	45	157
		SUX110	900-2700	60	231
			2701-3000	55	231
			3001-3900	50	231
			3901-4800	32	231

Notes: The above lintels are available for a 125-140mm inner leaf. To specify simply add an E to the end of the reference eg. SH110E.

Cavity (mm)	Inner Leaf (mm)	Lintel Reference	Length (mm)	SWL (kN)	Nom. Height (mm)
130-145	100-115	SH130	750-1800	17	140
			1801-2100	20	160
			2101-3600	26	220
		SU130	900-1800	32	157
			1801-2100	48	157
			2101-2400	45	157
		SUX130	900-2700	60	231
			2701-3000	55	231
			3001-3900	50	231
			3901-4800	32	231

Notes: The above lintels are available for a 125-140mm inner leaf. To specify simply add an E to the end of the reference eg. SH130E.

Cavity (mm)	Inner Leaf (mm)	Lintel Reference	Length (mm)	SWL (kN)	Nom. Height (mm)
150-165	100-115	SH150	750-1800	17	140
			1801-2100	20	160
			2101-3600	26	220
		SU150	900-1800	32	157
			1801-2100	48	157
			2101-2400	45	157
		SUX150	900-2700	60	231
			2701-3000	55	231
			3001-3900	50	231
			3901-4800	32	231

Notes: The above lintels are available for a 125-140mm inner leaf. To specify simply add an E to the end of the reference eg. SH150E.

Masonry Support Systems & Lintels

Single Leaf Lintels/Angle Lintels

These lintels carry a single leaf, usually the external leaf, of a cavity wall. Single leaf lintels require propping during installation to limit deflections. A separate dpc is required.

Lintel Reference	Length (mm)	SWL (kN)	Nom. Height (mm)
SL4	900-1200	4	88
SL5	1201-1500	5	131
SL7	750-1500	10	167
	1501-2100	7	167
SL10	2101-2400	10	215
SL15	750-1500	25	215
	1501-2100	18	215
	2101-3000	15	215
SL15H	750-1500	35	215
	1501-2100	25	215
	2101-2700	20	215
	2701-3900	15	215
SL20	750-1500	45	215
	1501-2100	30	215
	2101-2700	25	215
	2701-3300	20	215

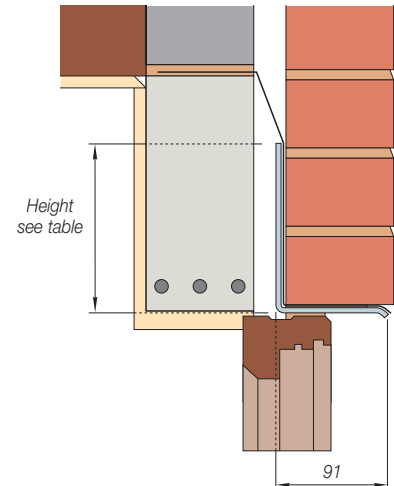

SL Single Leaf Lintel

Channel Lintels

The Channel Lintel is suitable for single leaf face brick or block walls and is fully built into the wall construction.

Lintel Reference	Length (mm)	SWL (kN)	Nom. Height (mm)
SC15	750-1800	15	154
SC20	750-1800	30	229
	1801-3000	20	229
SC20H	750-1500	75	229
	1501-2100	50	229
	2101-2700	40	229
	2701-3150	30	229
	3151-4800	20	229
SC20XH	750-2100	85	231
	2101-2700	65	231
	2701-3300	50	231
	3301-4800	30	231
	4801-5100	20	231

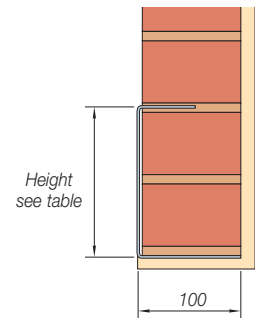

SC Channel Lintel

Solid Wall Lintels

For use with solid walls 215mm wide, these Lintels are built into the brickwork and are suitable for spans up to 2400mm.

Lintel Reference	Wall Width (mm)	Length (mm)	SWL (kN)	Nom. Height (mm)
SS50	215	750-1800	10	91
SS50H	215	750-2400	12	167

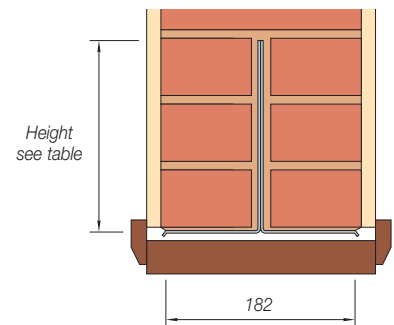

SS50 Light Duty Solid Wall Lintel

Box Beam Lintels

Box Lintels are suitable for use with solid or block walls.



Lintel Width (mm)	Lintel Reference	Length (mm)	SWL (kN)	Nom. Height (mm)
100	SW100	750-2100	19	143
		2101-2700	20	143
		2701-3600	29	219
		3601-4575	29	219
		4576-4800	27	219
	SW100X	750-1500	29	143
		1501-2100	39	143
		2101-2700	39	219
		2701-3600	51	219
		3601-4800	51	295
140	SW140	750-2100	19	143
		2101-2700	20	143
		2701-3600	29	219
		3601-4575	29	219
		4576-4800	27	219
	SW140X	750-1500	29	143
		1501-2100	39	143
		2101-2700	39	219
		2701-3600	51	219
		3601-4800	51	295

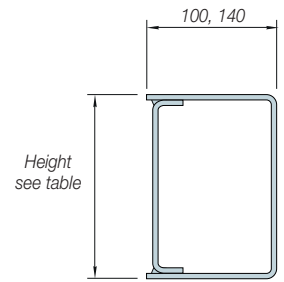

SW Lintels for 100-150mm walls

Timber Frame Lintels

These lintels are designed to support the external brickwork over openings in timber framed buildings. Timber frame lintels should be used with a separate dpc and are supplied with retaining clips to prevent lateral deflection during the build stage and should be used to achieve the loading figures shown.



Cavity (mm)	Lintel Reference	Length (mm)	SWL (kN)	Nom. Height (mm)
50-60	ST50	750-1200	4	128
		1201-1500	5	128
		1501-2400	7	183
		2401-3000	7	183
		3001-3600	9	218
		3601-4800	10	256
70-80	ST70	750-1200	4	145
		1201-1500	5	145
		1501-2400	7	187
		2401-3000	7	187
		3001-3600	9	218
		3601-4800	10	265
90-100	ST90	750-1500	5	146
		1501-2400	7	146
		2401-3000	7	201
		3001-3600	9	220
		3601-4800	10	271

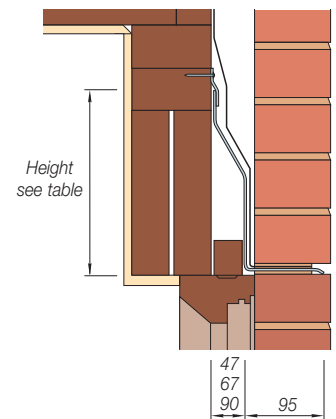

Timber Frame Lintel ST50, 70, 90

Masonry Support Systems & Lintels

Channel And Bolt Fixings

This is a selection of Ancon fixings. For complete information please refer to Ancon's Channel and Bolt Fixings brochure.

Cast-in Channels and T-Head Bolts

Cast-in Channels provide the necessary adjustment required when fixing to concrete and can eliminate site drilling. Fixing to channels is by 'T' head bolts. These are inserted into the channel and turned through 90°. The bolt must then be tightened to the correct torque.

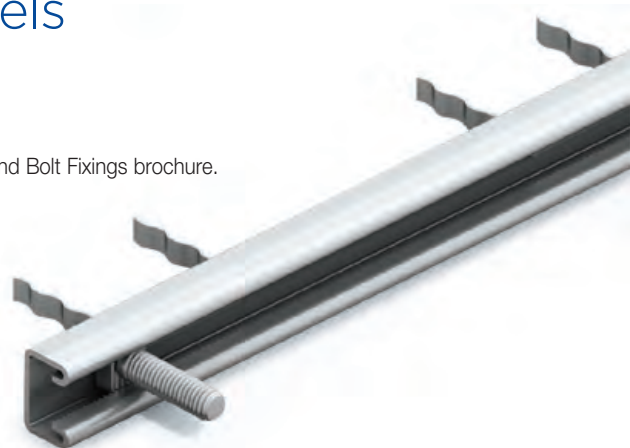

Expansion Bolts

We supply high performance throughbolts which have double expansion clips that reduce axial and edge spacing and achieve high performance even in cracked concrete. Available in grade 1.4401 as standard or high corrosion resistant 1.4571.



Capsule Anchors

The capsule contains epoxy resin, quartz granules and a hardener, and provides an expansion-free anchorage for stainless steel studs. These can be used in a variety of solid materials including concrete, stone and masonry.



Ancon Steelgrip

Ancon Steelgrip is a high performance fixing which simplifies the fixing of masonry support systems to hollow steel sections where access is only available from one side. This bolt is only available for use with Ancon systems. It features a serrated washer that corresponds with the serrations on all Ancon brackets. As the head is tightened to the correct torque, the sleeve expands.



Set Screws for Steel Frames

Ancon stainless steel set screws, nuts and washers are available in a range of thread sizes (M6 to M20) and are manufactured from grades A2 (1.4301) and A4 (1.4401) stainless steel. Set screws can be shrink-wrapped and are supplied complete with nylon washers to prevent bi-metallic corrosion when fixing to steel.



Projects



Bear Lane, London



Granary Wharf, Leeds



Big Wood School, Nottingham



Temple Quay, Bristol



Oxford Exchange, Belfast

Other Ancon Products

Masonry Reinforcement

Ancon AMR masonry reinforcement improves the structural performance of a wall by providing additional resistance to lateral loads. Located in the bed joint, it has a flattened profile to maintain good mortar cover even when lapped or used with wall ties.



Windposts and Parapet Posts

Large panels of masonry or panels with openings can often be difficult to justify structurally. Ancon Windposts are designed to provide additional lateral support for panels of brickwork. The range is manufactured from stainless steel and includes Windposts which can be installed into the inner leaf of blockwork and Windposts for installation into the cavity, which leave the blockwork undisturbed. Parapet Posts are used as vertical support for brickwork in either parapet or spandrel panels.



Wall Ties and Restraint Fixings

In addition to standard cavity wall ties, Leviat manufactures a range of Ancon fixings in a variety of lengths and types for restraining brickwork, blockwork and stonework. Restraints can be fixed to concrete and steelwork, as well as any type of masonry.



Tension Systems

Tie bars are increasingly being used in structures and buildings as an architectural as well as a structural element. Ancon Tension Systems comprise a range of components which can be supplied in carbon steel or stainless steel in a variety of sizes and finishes. A variety of assemblies can be created from simple tie bars to complex bracing systems involving several bars joined at one point.



Insulated Balcony Connectors

Ancon's thermally insulated connectors minimise heat loss at balcony locations while maintaining structural integrity. They provide a thermal break and, as a critical structural component, transfer moment, shear, tension and compression forces. Standard solutions are available for concrete-to-concrete, steel-to-concrete and steel-to-steel interfaces.



Punching Shear Reinforcement

Used within a slab to provide additional reinforcement around columns, Ancon Shearfix is the ideal solution to the design and construction problems associated with punching shear. The system consists of double-headed studs welded to flat rails, positioned around the column head or base.



Design Program Available



Leviat[®]
A CRH COMPANY

Innovative engineered products and construction solutions that allow the industry to build safer, stronger and faster.



Worldwide contacts for Leviat:

Australia

Leviat
98 Kurrajong Avenue,
Mount Druitt Sydney, NSW 2770
Tel: +61 - 2 8808 3100
Email: info.au@leviat.com

Austria

Leviat
Leonard-Bernstein-Str. 10
Saturn Tower, 1220 Wien
Tel: +43 - 1 - 259 6770
Email: info.at@leviat.com

Belgium

Leviat
Industrielaan 2
1740 Ternat
Tel: +32 - 2 - 582 29 45
Email: info.be@leviat.com

China

Leviat
Room 601 Tower D, Vantone Centre
No. A6 Chao Yang Men Wai Street
Chaoyang District
Beijing · P.R. China 100020
Tel: +86 - 10 5907 3200
Email: info.cn@leviat.com

Czech Republic

Leviat
Business Center Šafránková
Šafránková 1238/1
155 00 Praha 5
Tel: +420 - 311 - 690 060
Email: info.cz@leviat.com

Finland

Leviat
Vädursgatan 5
412 50 Göteborg / Sweden
Tel: +358 (0)10 6338781
Email: info.fi@leviat.com

France

Leviat
6, Rue de Cabanis
FR 31240 L'Union
Toulouse
Tel: +33 - 5 - 34 25 54 82
Email: info.fr@leviat.com

Germany

Leviat
Liebigstrasse 14
40764 Langenfeld
Tel: +49 - 2173 - 970 - 0
Email: info.de@leviat.com

India

Leviat
309, 3rd Floor, Orion Business Park
Ghodbunder Road, Kapurbawdi,
Thane West, Thane,
Maharashtra 400607
Tel: +91 - 22 2589 2032
Email: info.in@leviat.com

Italy

Leviat
Via F.lli Bronzetti 28
24124 Bergamo
Tel: +39 - 035 - 0760711
Email: info.it@leviat.com

Malaysia

Leviat
28 Jalan Anggerik Mokara 31/59
Kota Kemuning, 40460 Shah Alam
Selangor
Tel: +603 - 5122 4182
Email: info.my@leviat.com

Netherlands

Leviat
Oostermaat 3
7623 CS Borne
Tel: +31 - 74 - 267 14 49
Email: info.nl@leviat.com

New Zealand

Leviat
2/19 Nuttall Drive, Hillsborough,
Christchurch 8022
Tel: +64 - 3 376 5205
Email: info.nz@leviat.com

Norway

Leviat
Vestre Svanholmen 5
4313 Sandnes
Tel: +47 - 51 82 34 00
Email: info.no@leviat.com

Philippines

Leviat
2933 Regus, Joy Nostalg,
ADB Avenue
Ortigas Center
Pasig City
Tel: +63 - 2 7957 6381
Email: info.ph@leviat.com

Poland

Leviat
Ul. Obornicka 287
60-691 Poznan
Tel: +48 - 61 - 622 14 14
Email: info.pl@leviat.com

Singapore

Leviat
14 Benoi Crescent
Singapore 629977
Tel: +65 - 6266 6802
Email: info.sg@leviat.com

Spain

Leviat
Polígono Industrial Santa Ana
c/ Ignacio Zuloaga, 20
28522 Rivas-Vaciamadrid
Tel: +34 - 91 632 18 40
Email: info.es@leviat.com

Sweden

Leviat
Vädursgatan 5
412 50 Göteborg
Tel: +46 - 31 - 98 58 00
Email: info.se@leviat.com

Switzerland

Leviat
Grenzstrasse 24
3250 Lyss
Tel: +41 - 31 750 3030
Email: info.ch@leviat.com

United Kingdom

Leviat
President Way, President Park,
Sheffield, S4 7UR
Tel: +44 - 114 275 5224
Email: info.uk@leviat.com

United States of America

Leviat
6467 S Falkenburg Rd.
Riverview, FL 33578
Tel: (800) 423-9140
Email: info.us@leviat.us

For countries not listed

Email: info@leviat.com

Leviat.com

Notes regarding this catalogue

© Protected by copyright. The construction applications and details provided in this publication are indicative only. In every case, project working details should be entrusted to appropriately qualified and experienced persons. Whilst every care has been exercised in the preparation of this publication to ensure that any advice, recommendations or information is accurate, no liability or responsibility of any kind is accepted by Leviat for inaccuracies or printing errors. Technical and design changes are reserved. With a policy of continuous product development, Leviat reserves the right to modify product design and specification at any time.



For more information on these products, contact:

Leviat

President Way
President Park
Sheffield, S4 7UR
United Kingdom

Tel: +44 (0) 114 275 5224

Fax: +44 (0) 114 276 8543

Email: info.ancon.uk@leviat.com

For sales enquiries:

Email: sales.ancon.uk@leviat.com

For technical enquiries:

Email: tech.ancon.uk@leviat.com

Ancon.co.uk

Leviat.com

Imagine. Model. Make.

Leviat.com