

Ancon Building Products

President Way
President Park
Sheffield
South Yorkshire S4 7UR
Tel: 0114 2755224 Fax: 0114 2381240
e-mail: info@ancon.co.uk
website: www.ancon.co.uk



HAPAS Certificate
15/H240
Product Sheet 1

PRODUCTS FOR STRUCTURAL CONCRETE

ANCON MBT ET-TYPE COUPLERS

This HAPAS Certificate Product Sheet⁽¹⁾ is issued by the British Board of Agrément (BBA), supported by Highways England (HE) (acting on behalf of the Overseeing Organisations of the Department for Transport; Transport Scotland; the Welsh Assembly Government and the Department for Regional Development, Northern Ireland), the Association of Directors of Environment, Economy, Planning and Transport (ADEPT), the Local Government Technical Advisers Group and industry bodies. HAPAS Certificates are normally each subject to a review every three years.
(1) Hereinafter referred to as 'Certificate'.

This Certificate relates to Ancon MBT ET-Type Couplers, for mechanical connection of straight deformed high-yield carbon steel bars (grade 500) used for the reinforcement of concrete. The jointed bars can be subjected to shear, compressive or tensile stresses.

CERTIFICATION INCLUDES:

- factors relating to compliance with HAPAS requirements
- factors relating to compliance with Regulations where applicable
- independently verified technical specification
- assessment criteria and technical investigations
- design considerations
- installation guidance
- regular surveillance of production
- formal three-yearly review.

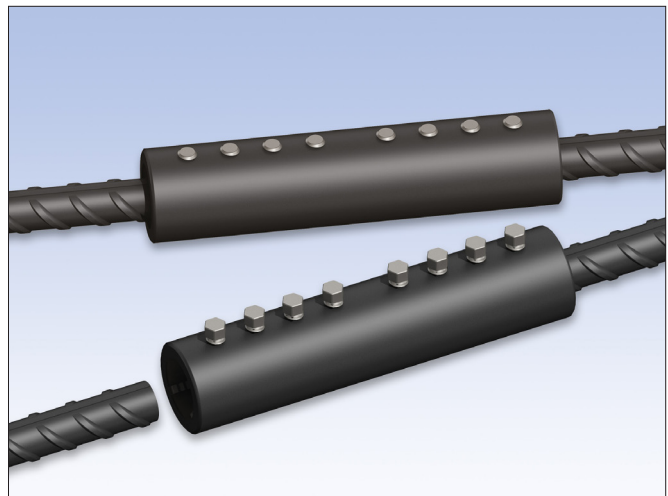

KEY FACTORS ASSESSED

Practicability of installation — the couplers are to be installed by competent personnel in accordance with the Certificate holder's installation instructions (see section 5).

Strength — the couplers have 100% strength of the bar being joined and have adequate fatigue strength for use as a class D detail meeting HE's fatigue requirement for couplers (see section 6).

Durability — the jointed bars will have the same service life as for the reinforced concrete elements, provided they are installed with adequate cover (see section 8).

The BBA has awarded this Certificate to the company named above for the product described herein. This product has been assessed by the BBA as being fit for its intended use provided it is installed, used and maintained as set out in this Certificate.

On behalf of the British Board of Agrément

Date of First issue: 18 November 2015

Originally certificated on 7 September 1998 with Certificate No 98/R102

Brian Chamberlain
Head of Technical Excellence

Claire Curtis-Thomas
Chief Executive

The BBA is a UKAS accredited certification body — Number 113. The schedule of the current scope of accreditation for product certification is available in pdf format via the UKAS link on the BBA website at www.bbacerts.co.uk

Readers are advised to check the validity and latest issue number of this Agrément Certificate by either referring to the BBA website or contacting the BBA direct.

British Board of Agrément
Bucknalls Lane
Watford
Herts WD25 9BA

tel: 01923 665300
fax: 01923 665301
clientservices@bba.star.co.uk
www.bbacerts.co.uk

©2015

Requirements

In the opinion of the BBA, Ancon MBT ET-Type Couplers, when used in accordance with the provisions of this Certificate, will satisfy or contribute to satisfying the requirements for proprietary mechanical joints in reinforcing bars in the *Manual of Contract Documents for Highways Works (MCHW)*⁽¹⁾, Volume 1 *Specification for Highways Works (SHW)*, Series 1700 *Structural Concrete* and Standard BD 24/92.

(1) The MCHW is operated by the Overseeing Organisations: Highways England (HE), Transport Scotland, the Welsh Assembly Government and the Department for Regional Development (Northern Ireland).

Regulations

Construction (Design and Management) Regulations 2015

Construction (Design and Management) Regulations (Northern Ireland) 2007

Information in this Certificate may assist the client, Principal Designer/CDM co-ordinator, designer and contractors to address their obligations under these Regulations.

See sections: *3 Delivery and site handling and 5 Practicability of Installation* of this Certificate.

Technical Specification

1 Description

1.1 Ancon MBT ET-Type Couplers are for use in joining lengths of straight deformed high-yield carbon steel reinforcing bars (grade 500) in accordance with BS 4449 : 2005.

1.2 The couplers comprise:

- steel sleeve — manufactured from hot-rolled, seamless steel tubing. Each sleeve is drilled and tapped for the appropriate number of bolts (see Table 1). Saddles (high-tensile steel strips with serrated faces) are TIG-welded at the saddle ends, two saddles per sleeve. Sleeves can also be supplied with a centre stop, fixed in position to provide accurate location of the coupler on the reinforcing bars
- lockshear bolts — steel bolts, incorporating hexagonal heads and reduced diameter shank shear planes and conical ends (see Figure 1)
- centre stop pin (optional feature) — for bar location.

Table 1 Coupler specification

Coupler reference	Nominal bar diameter (mm)	Coupler outside diameter (mm)	Overall length (mm)	Approximate weight, including bolts (kg)	Number of bolts per sleeve	Minimum failure load 115% $C_v^{(1)}$ (kN)
ET10	10	33.4	100	0.52	4	45.1
ET12	12	33.4	140	0.71	6	65.0
ET16	16	42.2	160	1.25	6	115.6
ET20	20	48.3	204	2.03	8	180.6
ET25	25	54.0	258	3.00	8	282.3
ET32	32	71.0	312	6.50	10	462.3
ET40	40	81.0	484	11.30	14	722.8

(1) Characteristic strength (C_v) is the value of yield stress below which not more than 5% of the test results fall, where tests are carried out in accordance with BS 4449 : 2005, Annex E. Characteristic strength for grade 500 deformed high-yield steel is 500 N·mm⁻². For verification purposes, test specimen dimensions should comply with the Certificate holder's specifications.

Figure 1 Typical coupler

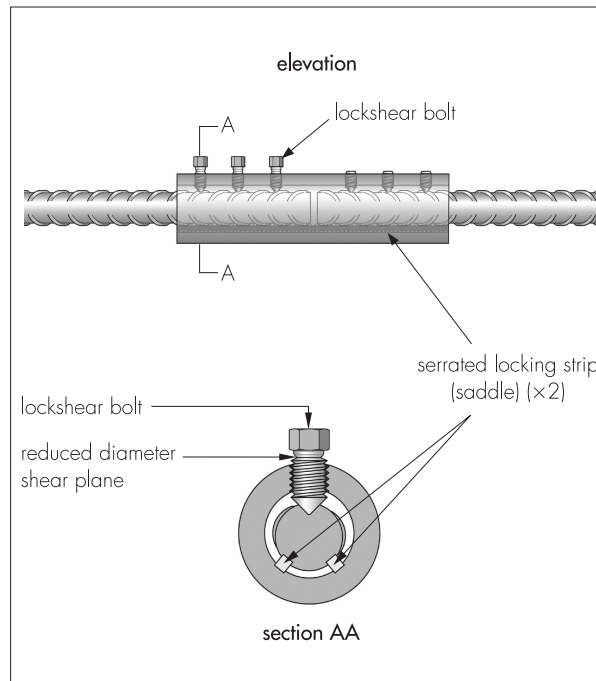

1.3 The range of assessed couplers, with dimensions and characteristics, is shown in Table 1.

Locking mechanism

1.4 The couplers are designed so that, as the bolts are tightened, they penetrate the reinforcing bar, simultaneously forcing the bar into the serrated surface of the two saddle strips (see Figure 1).

1.5 The bolt shank diameter is reduced to ensure bolt heads will shear off at a predetermined torque. At this torque, the required bite depth and the required resistance to axial pull-out are achieved.

2 Manufacture

2.1 Materials used in the manufacture of the couplers are listed in Table 2.

Table 2 Material specification

Component	Specification (minimum values)
Sleeve tube	Ultimate tensile strength 600 N·mm ⁻² , elongation 18%
Bolt	Tensile strength 525 N·mm ⁻²
Saddle	Tensile strength 700 N·mm ⁻²

2.2 The coupler consists of three components: tube, serrated saddles and lockshear bolts.

- tube — normally, tube is supplied to the coupler length; this is then drilled and tapped to receive the lockshear bolts
- saddles — after heat treatment, the saddle blanks are machined to form the serrations
- bolts — the bolts are manufactured from hexagonal bar and after machining, the points are hardened by heat treatment.

2.3 As part of the assessment and ongoing surveillance of product quality, the BBA has:

- agreed with the manufacturer the quality control procedures and product testing to be undertaken
- assessed and agreed the quality control operated over batches of incoming materials
- monitored the production process and verified that it is in accordance with the documented process
- evaluated the process for management of nonconformities
- checked that equipment has been properly tested and calibrated
- undertaken to carry out the above measures on a regular basis through a surveillance process, to verify that the specifications and quality control operated by the manufacturer are being maintained.

2.4 The management system of Ancon Building Products has been assessed and registered as meeting the requirements of BS EN ISO 9001 : 2008 by BSI (FM 12226).

3 Delivery and site handling

3.1 Couplers, complete with bolts and installation instructions, are supplied in polythene bags. The coupler type and batch number (eg ET32 667M) are recorded on the installation instructions. Each individual coupler sleeve is also hard stamped on the outside, at one end, with the same information.

3.2 Couplers must not be removed from their packaging until ready for use and must not be left exposed to the effects of atmospheric corrosion prior to assembly.

3.3 Bolts supplied with each coupler are specifically for use with that coupler and, therefore, it is vital that only these are used. Should bolts be lost, replacements must be obtained from the Certificate holder.

3.4 If any element of a completed joint is to be exposed to conditions in which corrosion might occur, both ends of the coupler must be sealed by tape. Similarly, if there is a risk of ice forming within the coupler sleeve, this same precaution must be taken to prevent water retention within the joint.

Assessment and Technical Investigations

The following is a summary of the assessment and technical investigations carried out on Ancon MBT ET-Type Couplers.

Design Considerations

4 General

4.1 Ancon MBT ET-Type Couplers are satisfactory for use in joining lengths of straight reinforcing steel bars in accordance with BS 4449 : 2005, and for use in reinforced concrete structures (designed in accordance with HE requirements).

4.2 The completed joints are for use in locations where they can be subject to shear, compressive or tensile stress.

4.3 The design of any highway structure incorporating these couplers must be carried out by a suitably qualified engineer in accordance with the requirements of the Overseeing Organisation.

4.4 Concrete cover (ie the distance from the sleeve face to the nearest concrete surface) must be provided in accordance with BS 5400-4 : 1990, Table 13, and Departmental Standard BD 57/01 or BS EN 1992-2 : 2005.

4.5 When detailing, particular care must be taken to ensure that:

- the required nominal concrete cover is provided to the sleeve (see Figure 2). It may not always be possible to achieve this and in such instances, and at the discretion of the engineer responsible for the design, a coated protection may be applied to the tube
- there is adequate spacing of the reinforcement in the splice area for the penetration of the concrete and for tightening the bolts; spacing between the coupler and the adjacent bar should be in accordance with BS 5400-4 : 1990, Clause 5.8.8.1
- where possible, joints are positioned away from points of high stress
- the position of adjacent splices are staggered. It may not, however, always be practical to stagger couplers; by taking into account the location and design stresses in the coupler, the requirement to stagger the couplers may be waived by the engineer responsible for the design.

Figure 2 Cover detail

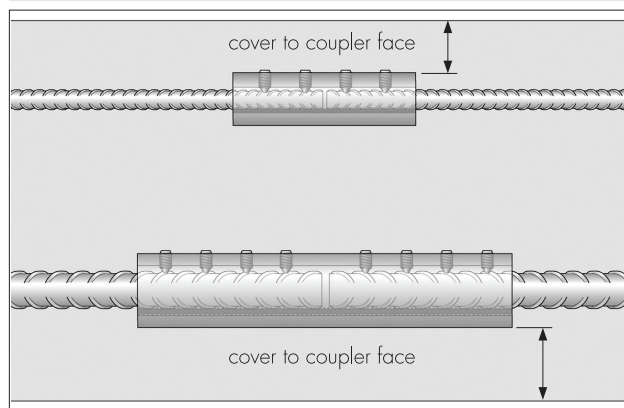

5 Practicability of installation

5.1 The coupler is designed to be installed by a competent highways contractor, experienced with this type of product.

5.2 Installation of the couplers must be carried out strictly in accordance with the Certificate holder's installation instructions, HE requirements and this Certificate.

5.3 Adequate site supervision must be provided to ensure that couplers are installed correctly.

6 Strength

Tensile strength

6.1 Tensile tests on assembled joints show that the couplers specified in Table 1 will satisfy the test requirement of the HE specification and, therefore, can be considered to have a strength of 100% of the bars being joined.

6.2 Tests carried out indicate the ET-Type couplers comply with Highways England's current requirement that fatigue performance exceeds the requirements for the Class D design curve given in BS 5400-10C : 1999. Joints using ET-Type couplers, therefore, can be classified as a Class D detail.

Crack widths

6.3 Tests carried out on concrete beams reinforced with steel reinforcing bars joined using the couplers indicate that the crack widths measured are comparable with those of concrete beams with continuous reinforcement.

7 Maintenance

Once embedded in concrete, maintenance of the coupler and joined steel reinforcing bar is not required.

8 Durability

The couplers will not adversely affect the durability of the reinforced concrete member provided that good quality concrete is used in conjunction with adequate cover to the coupler, and the crack width criteria of BS 5400-4 : 1990 are satisfied.

Installation

9 General

9.1 Installation of Ancon MBT ET-Type Couplers must be carried out strictly in accordance with the Certificate holder's instructions, HE requirements and this Certificate.

9.2 A typical installation is shown in Figure 3.

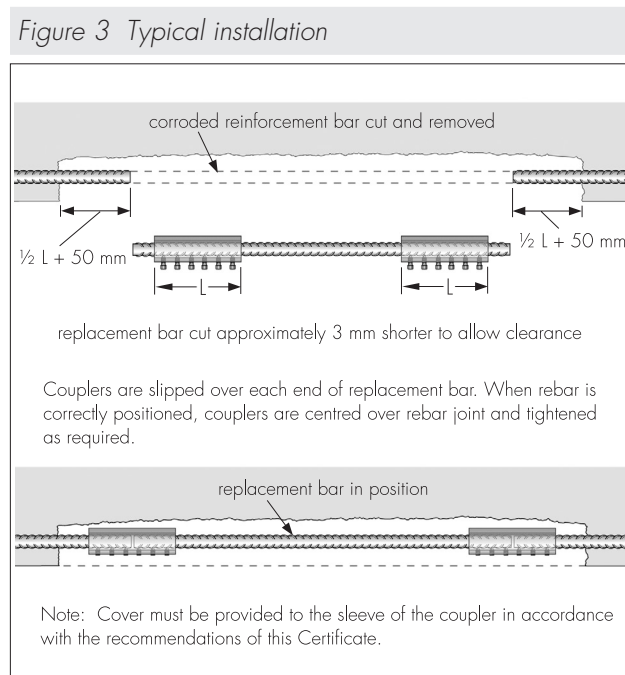

9.3 The ends of steel reinforcing bars to be coupled should be cut or sheared in accordance with normal practice. The surface condition of the bars must meet HE requirements.

9.4 The sleeve must be centrally located over the point of contact between the reinforcing bars.

9.5 Care must be taken when inserting reinforcing bars into the coupler sleeve, as excess force may result in loss, or displacement, of the serrated saddles and will compromise the connection efficiency.

10 Procedure

10.1 The coupler is placed over the end of the fixed bar to a distance of a half coupler length [$\pm 6 \text{ mm}$ or until the centre pin (where supplied) butts against bar end]. The bolts are finger-tightened into the sleeve and alignment checked and adjusted if necessary (see Figure 4).

10.2 The second bar end is placed into the coupler until it butts against the fixed bar or coupler centre pin (where supplied), and the remaining bolts are secured finger-tight in position, again checking for alignment (see Figure 4).

10.3 On one half of the coupler, starting from the centre of the coupler and working outwards to the end of the coupler, all of the lockshear bolts are partially tightened using the appropriate tool.

10.4 Step 10.3 is repeated again, starting from the centre of the coupler and working towards the end of the coupler. All of the lockshear bolts are fully tightened using the appropriate tool, until the bolt heads shear off.

10.5 Steps 10.3 and 10.4 are then completed for the other half of the coupler.

10.6 Care must be taken to ensure excess water does not remain within the coupler prior to completion of the joint.

10.7 Where the target slump of the concrete is less than 100 mm, the ends of the coupler should be filled with cement grout prior to casting, to prevent ingress of water.

Figure 4 Installation detail

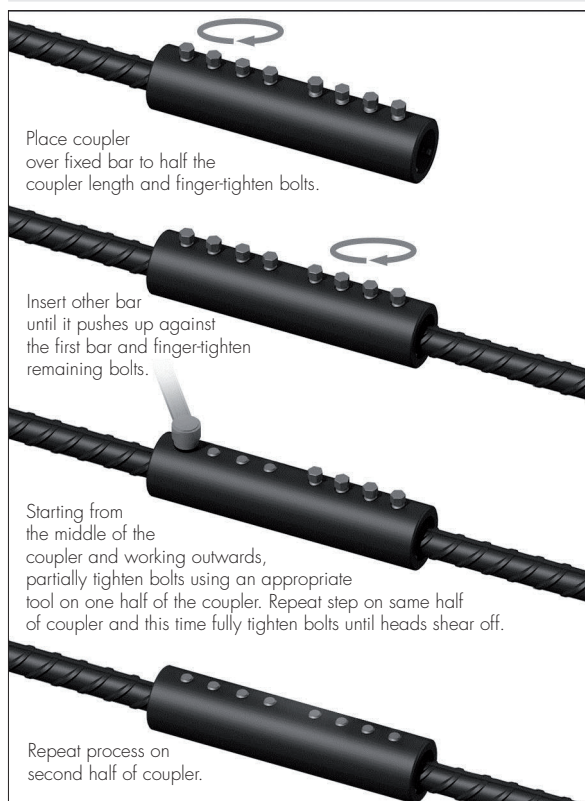

Technical Investigations

11 Tests

11.1 Tests were carried out and the results assessed to determine:

- dimensional accuracy
- tensile strength of joints
- practicability of installation
- permanent deformation after loading to 0.65 times the specified reinforcement characteristic strength and unloading to zero
- bolt shearing torque
- fatigue performance of the couplers when subjected to axial stress in air
- fatigue performance of concrete beams with reinforcing bars joined by the couplers.

11.2 An evaluation was made relating to:

- stress/strain relationships
- cyclic tensile tests
- strength under compressive loading
- durability
- contamination of joints
- effect of creep
- performance of the loaded coupler under increased temperature conditions.

12 Investigations

12.1 The manufacturing process was evaluated, including the methods adopted for quality control, and the quality and composition of the metals used were assessed.

12.2 A site visit was carried out to evaluate the practicability of installation.

12.3 An assessment was made of the Certificate holder's installation instructions, and of the products in relation to HE requirements.

12.4 Technical data were assessed concerning the behaviour of the couplers under increased temperature.

Bibliography

BS 4449 : 2005 *Steel for the reinforcement of concrete — Weldable reinforcing steel — Bar, coil and decoiled product — Specification*

BS 5400-4 : 1990 *Steel, concrete and composite bridges — Code of practice for design of concrete bridges*

BS 5400-10C : 1999 *Steel, concrete and composite bridges — Charts for classification of details for fatigue*

BD 24/92 : 1992 *The design of concrete highway bridges and structures use of BS 5400-4 : 1990*

BD 57/01 *Design for Durability*

BS EN 1992-2 : 2005 *Eurocode 2 : Design of concrete structures — Concrete bridges — Design and detailing rules*

BS EN ISO 9001 : 2008 *Quality management systems — Requirements*

Manual of Contract Documents for Highway Works, Volume 1 Specification for Highway Works, August 1998 (as amended)

Technical Approval of Couplers for Reinforcing Steel for Use in Highway Structures

13 Conditions

13.1 This Certificate:

- relates only to the product/system that is named and described on the front page
- is issued only to the company, firm, organisation or person named on the front page — no other company, firm, organisation or person may hold or claim that this Certificate has been issued to them
- is valid only within the UK
- has to be read, considered and used as a whole document — it may be misleading and will be incomplete to be selective
- is copyright of the BBA
- is subject to English Law.

13.2 Publications, documents, specifications, legislation, regulations, standards and the like referenced in this Certificate are those that were current and/or deemed relevant by the BBA at the date of issue or reissue of this Certificate.

13.3 This Certificate will remain valid for an unlimited period provided that the product/system and its manufacture and/or fabrication, including all related and relevant parts and processes thereof:

- are maintained at or above the levels which have been assessed and found to be satisfactory by the BBA
- continue to be checked as and when deemed appropriate by the BBA under arrangements that it will determine
- are reviewed by the BBA as and when it considers appropriate.

13.4 The BBA has used due skill, care and diligence in preparing this Certificate, but no warranty is provided.

13.5 In issuing this Certificate, the BBA is not responsible and is excluded from any liability to any company, firm, organisation or person, for any matters arising directly or indirectly from:

- the presence or absence of any patent, intellectual property or similar rights subsisting in the product/system or any other product/system
- the right of the Certificate holder to manufacture, supply, install, maintain or market the product/system
- actual installations of the product/system, including their nature, design, methods, performance, workmanship and maintenance
- any works and constructions in which the product/system is installed, including their nature, design, methods, performance, workmanship and maintenance
- any loss or damage, including personal injury, howsoever caused by the product/system, including its manufacture, supply, installation, use, maintenance and removal
- any claims by the manufacturer relating to CE marking.

13.6 Any information relating to the manufacture, supply, installation, use, maintenance and removal of this product/system which is contained or referred to in this Certificate is the minimum required to be met when the product/system is manufactured, supplied, installed, used, maintained and removed. It does not purport in any way to restate the requirements of the Health and Safety at Work etc. Act 1974, or of any other statutory, common law or other duty which may exist at the date of issue or reissue of this Certificate; nor is conformity with such information to be taken as satisfying the requirements of the 1974 Act or of any statutory, common law or other duty of care.