

Design Sheet - Hammer-On Tie and Head Restraint

Please provide: contact details; project details and design conditions

Contact Details

Contact name

Company

Address

.....

.....

Tel

Fax

Email

Project name and town

Tick boxes as appropriate

Order Quotation Request

Delivery to contact address

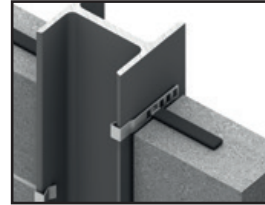

Hammer-on Column Tie

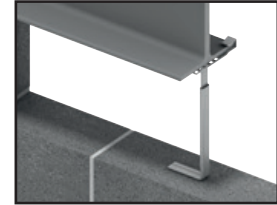

Hammer-on Head Restraint

Hammer-on Column Tie

Components

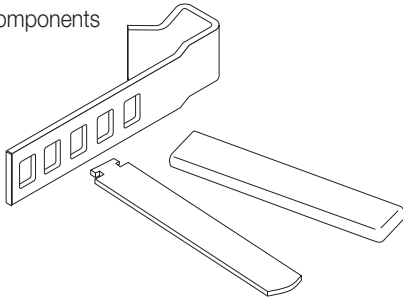

Your Application

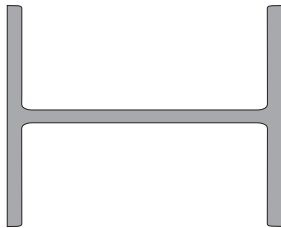

a = mm

b = mm

c = mm

d1 = mm

d2 = mm

Example Application in Plan View

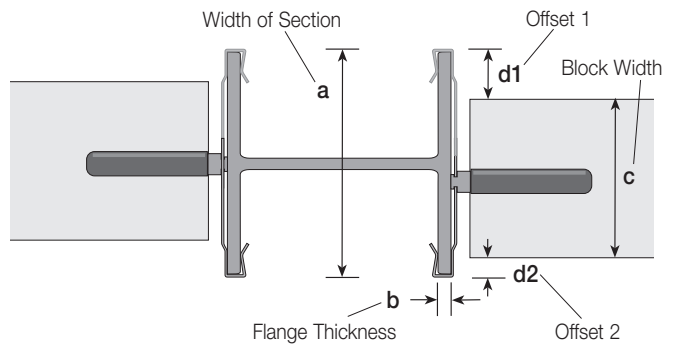

Quantity required No.

Hammer-on Head Restraint (IHR-H)

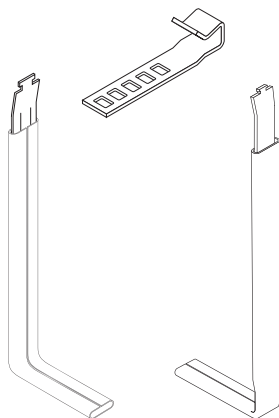

Your Application

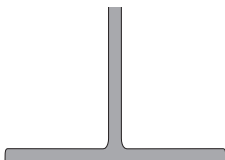

a = mm

b = mm

c = mm

d1 = mm

d2 = mm

Example Application in Section View

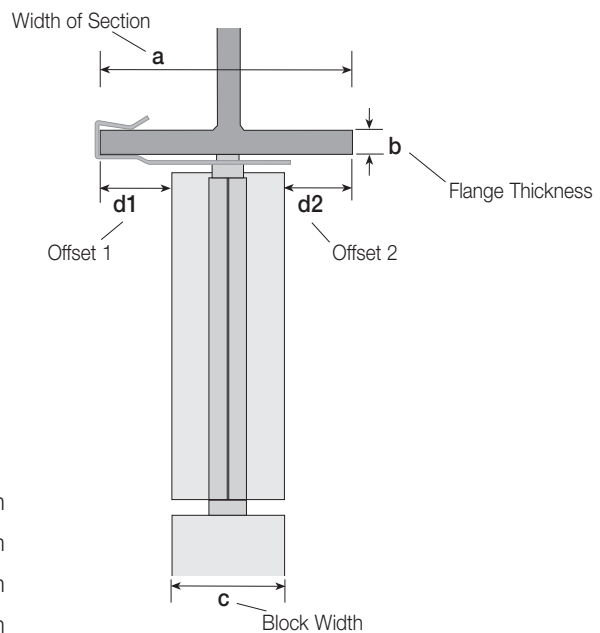

Quantity required No.

Email to info.ancon.uk@leviat.com

Leviat, President Way, President Park, Sheffield, S4 7UR, UK.
Tel: +44 (0) 114 275 5224, Web: Ancon.co.uk | Leviat.com

