

# Installation Guide

## Ancon Bracket Support System

Ancon Bracket Support Systems are generally fixed to concrete frames. Vertical, horizontal and lateral tolerances are catered for in the following procedure.

### Cavity Variation

- Increase in cavity** is accommodated by inserting full height stainless steel shims between the structural face and the back of the bracket up to a maximum thickness of the outside diameter of the fixing bolt or 16mm, whichever is less. When utilising shims they must be of sufficient length to extend to the lowest point of contact between the bracket and the structure.
- Decrease in cavity** is overcome by re-positioning the brick on the support plate, thus increasing the amount of actual support under the brick. Design criteria govern the extent of allowable movement.

### Horizontal adjustment

Horizontal cast-in channel will provide virtually unlimited lateral adjustment of the brackets.

### Vertical adjustment

The vertical slot in the back of the bracket allows up to 50mm vertical adjustment i.e.  $\pm 25\text{mm}$  with an M12 bolt.

### Fixings

It is important to utilise the fixings supplied as these are an integral component of the design. Serrated washers must be installed in the correct orientation i.e. serrations horizontal to match those on the bracket. Ensure nuts are tightened to the specified tightening torque (see Installation Guide—Bolts). Where individual brackets incorporate stirrups to support hanging brickwork, it is important that the following points are noted:

- The brickwork requires support framework until the mortar has cured, and achieved a suitable strength.
- All perpend and the holes which accommodate the stitching rods must be completely filled with mortar.
- The 300mm long stitching rods should overlap the stirrups by approximately 30mm each end.
- Where high strength bricks with low water absorption are used, the mortar must be of sufficient strength to ensure bonding and cohesion of the suspended masonry.

Wall ties should be provided at a recommended maximum horizontal spacing of 450mm within 300mm above the support angle.

### Safety Precautions

Ancon stainless steel products are produced from laser-cut plate. As with all such industrial fabrications, these may present sharp edges. **Suitable personal protective equipment should be worn at all times during handling and installation.**

The Construction applications and details provided in this guide are indicative only. In every case installation should be entrusted to appropriately qualified and experienced persons. Normal handling precautions should be taken to avoid physical injury. The company cannot be held responsible for any injury as a result of using our products, unless such injury arises as a result of our negligence. © Protected by copyright

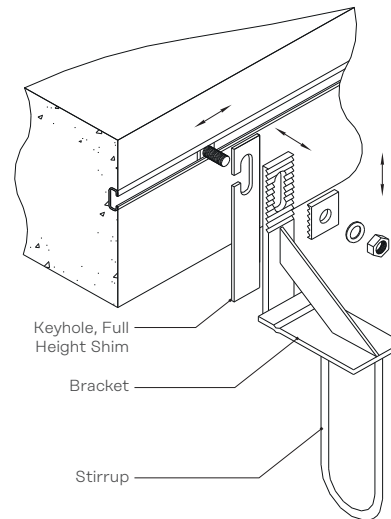

### Adjustment of individual bracket

