

Design Sheet - Ancon Coping Restraint

Please provide: Project details; Contact details; Design conditions; Tick all applicable boxes.

Contact Details

Contact name
 Company
 Address

 Tel
 Email

Project Details

Project name
 Project address

 Quote Specification Order

Application

Ancon Coping Restraint, comprising L-shaped cramp and 6mm x 60mm loose dowel

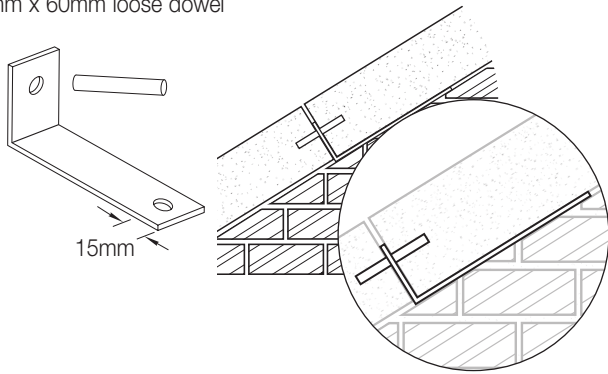

Design Conditions

Height (inner) a mm
 Height (outer) b mm
 Width c mm
 Height Centre d mm
 Length mm
 Density (If blank, 3000kg/m³ assumed) kg/m³
 Pitch Angle (If blank, stone laid flat assumed) °

Select Stone Configuration

- 1.
- 2.
- 3.
- 4. Other (Please sketch and attach separately)

