

Leviat®

Ancon®

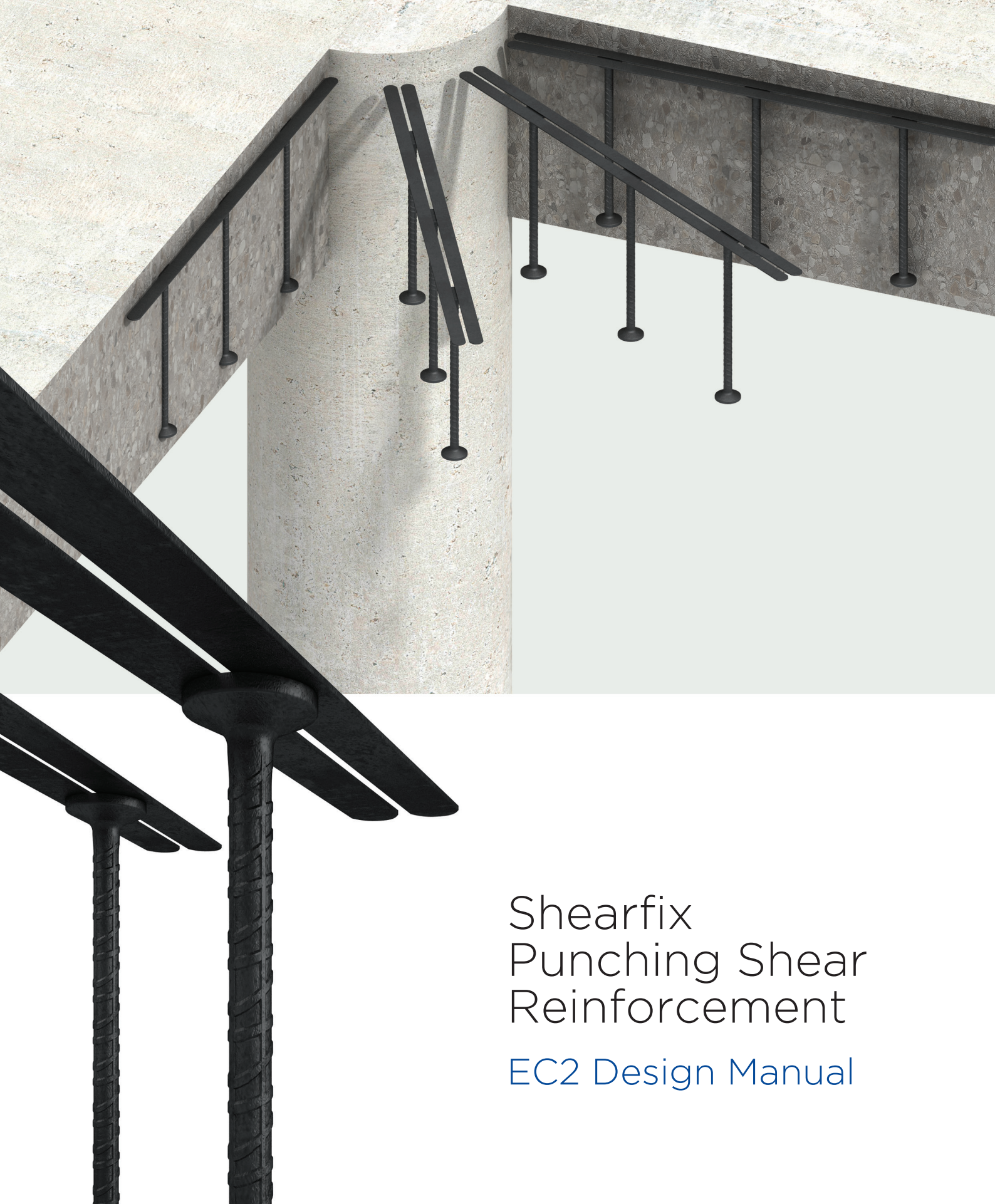

Shearfix
Punching Shear
Reinforcement

EC2 Design Manual

Ancon Shearfix EC2 Design Manual

Contents

List of Figures	3
List of equations.....	3
List of tables	3
1 Symbols	4
1.1 Latin Upper Case.....	4
1.2 Latin Lower Case.....	4
1.3 Greek Lower Case	6
2 References	6
3 Introduction	7
4 Design Information and Assumptions.....	8
4.1 Information required.....	8
4.2 Design Assumptions	8
4.3 Software Defaults	8
5 Slab depth, h	9
6 Effective depth, d.....	9
7 Reinforcement ratio, ρ	9
8 Column and edge dimensions.....	10
8.1 Edge dimensions.....	11
8.2 Edge dimension limits.....	11
9 Column locations and virtual slab openings	12
10 Eccentricity factor β	13
10.1 General formula for β values.....	14
10.2 Internal column with biaxial moments.....	14
10.3 Edge column with moment towards interior of slab.....	15
10.4 Corner column with moment towards interior of slab	15
10.5 Default β -value	16
11 Parameters for calculating β -values	16
11.1 Translation of moments	16
11.2 Control perimeters	17
11.3 W_1 values	20

12	Slab openings	20
13	Shear stress calculations	22
14	National Annex parameter values	25
15	Layout of punching shear reinforcement	25
15.1	Radial layout general procedure	26
15.2	Cruciform layout general procedure	27
15.3	Rails near slab openings and distribution rails	28
16	Design Examples	29
16.1	Internal rectangular column	30
16.1.1	Inputs	30
16.1.2	Design	30
16.1.3	Design solution	35
16.2	Edge oval column.....	36
16.2.1	Inputs	36
16.2.2	Design	36
16.2.3	Design solution	41
16.3	Corner rectangular column.....	43
16.3.1	Inputs	43
16.3.2	Design	44
16.3.3	Design solution	50
16.4	Re-entrant corner circular column	51
16.4.1	Inputs	51
16.4.2	Design	52
16.4.3	Design solution	55

Document Version Notes (all latest modifications of document highlighted)

5.0	29 October 2018	First issued
5.7	7 January 2020	u_0 and u_1^* control perimeters modified (11.2; tables 3, 4 and 5; design examples 2, 3 and 4)
5.10	15 January 2021	u_1^* control perimeters reduce at openings, β calc's modified to suit (10; 12; equations 7, 8, 9)
6.0	6 April 2021	removal of references to version 5 where they may cause confusion
6.3	1 June 2026	rewrite of calculation core effecting rail layouts

List of Figures

Figure 1 Reinforcement in the slab.....	9
Figure 2 Edge dimensions	11
Figure 3 BS EN 1992-1-1:2004, Figure 6.15 Basic control perimeters for edge and corner columns..	12
Figure 4 BS EN 1992-1-1:2004, Figure 6.13 Typical basic control perimeters around loaded areas ...	12
Figure 5 User-defined edge column designed as internal column with virtual opening at slab edge.	13
Figure 6 BS EN 1992-1-1:2004, Figure 6.21N Recommended values for β	14
Figure 7 BS EN 1992-1-1:2004, Figure 6.13 Definition of b_y and b_z values	15
Figure 8 Translation of moment about column to moment about basic control perimeter.....	16
Figure 9 BS EN 1992-1-1:2004, 6.4.5(3) column face perimeters.....	17
Figure 10 BS EN 1992-1-1:2004 Figure 6.13 Typical basic control perimeters around loaded areas..	17
Figure 11 BS EN 1992-1-1:2004, Figure 6.15 Basic control perimeters for edge and corner columns	17
Figure 12 BS EN 1992-1-1:2004 Figure 6.20 Reduced basic control perimeter u_1^*	17
Figure 13 Control perimeter near openings, developed from BS EN 1992-1-1:2004 Figure 6.14.....	21
Figure 14 Radial layout setting out points	26
Figure 15 Radial layout of rails for internal rectangular column with associated outer control perimeter	27
Figure 16 (i) and (ii) Cruciform layout procedure	27
Figure 17 Cruciform rail layout and associated effective outer perimeter	28
Figure 18 Example rail layout with deleted rails and ineffective main rails	29

List of equations

Equation 1 Calculation of the effective depth of the slab, d	9
Equation 2 Calculation of the slab reinforcement ratio, based on BS EN 1992-1-1:2004, 6.4.4 (1).....	9
Equation 3 General formula for beta-value adapted version of eq. (6.39)	14
Equation 4 BS EN 1992-1-1:2004 (6.43), β for internal rectangular column with biaxial moments ...	14
Equation 5 BS EN 1992-1-1:2004 eq. (6.44) β : edge column with loading towards interior of slab ...	15
Equation 6 BS EN 1992-1-1:2004 eq. (6.46) β : edge column where eccentricity is towards interior .	15
Equation 7 Translation of moment.....	16
Equation 8 BS EN 1992-1-1:2004 eq. (6.40) Definition of W_i as a function of a control perimeter	20
Equation 9 BS EN 1992-1-1:2004 eq. (6.41), W_1 formula for internal rectangular column.....	20
Equation 10 BS EN 1992-1-1:2004 eq. (6.45), W_1 formula when $a_1 = a$, $b_1 = b$ and edge distance = 0	20

List of tables

Table 1 BS EN 1992-1-1:2004, Table 6.1 Values of k for rectangular loaded areas.....	14
Table 2 BS EN 1992-1-1:2004 Figure 6.21N, Default ("Recommended") values for β	16
Table 3 Control perimeters u_0 , u_1 and u_1^* (see Table 4 & Table 5 below for parameter definitions).	18
Table 4 Control perimeter parameters	19
Table 5 Edge distance parameters.....	19

1 Symbols

1.1 Latin Upper Case

A_{cy}	Concrete area in the y direction
A_{cz}	Concrete area in the z direction
A_{sw}	Area of one perimeter of shear reinforcement
A_{sy}	Area of slab reinforcement in y-direction per metre of slab (number suffix → layer number)
A_{sz}	Area of slab reinforcement in z-direction per metre of slab (number suffix → layer number)
$C_{Rd,c}$	According to NA to BS EN 1992-1-1, 6.4.4 (1)
D	Diameter of circular column
L	Column dimension parallel to flat face of oval column
L_1	Effective column dimension parallel to flat face of oval column
M_{Ed}	Design moment about centroid of column (with y/z suffix → about y/z axis)
M'_{Ed}	Design moment about centroid of basic control perimeter (with y/z suffix → about y/z axis)
$N_{Ed,y}$	Longitudinal forces across the critical section in the y direction
$N_{Ed,z}$	Longitudinal forces across the critical section in the z direction
V_{Ed}	Design value of the applied shear force
W_1	Integral of the basic control perimeter length by the distance from its centroidal axis (with y/z suffix → relative to y/z axis)

1.2 Latin Lower Case

a	Larger dimension of a rectangular column
a_1	Effective dimension of a rectangular column corresponding to the actual dimension, a
$a_{e,y}$	Distance between the column face and the edge of the slab in the y-direction
$a_{e,z}$	Distance between the column face and the edge of the slab in the z-direction
b	Smaller dimension of a rectangular column
b_1	Effective dimension of a rectangular column corresponding to the actual dimension, b
b_y	Dimension of the control perimeter in the y direction
b_z	Dimension of the control perimeter in the z direction
c_1	Column dimension parallel to the eccentricity of the load
c_2	Column dimension perpendicular to the eccentricity of the load
c_3	Distance of radial setting out point from corner of column, parallel to column dimension z
c_4	Distance of radial setting out point from corner of column, parallel to column dimension y
$c_{nom,t}$	Dimension of the concrete cover at the top of slab
$c_{nom,b}$	Dimension of the concrete cover at the bottom of slab
d	Mean effective depth of the slab
d_y	Effective depth of the reinforcement in the y direction (with number suffix → layer number)
d_z	Effective depth of the reinforcement in the z direction (with number suffix → layer number)
e	(1) Distance from the centroid of the basic control perimeter, u_1 (2) Eccentricity of the applied load (a) y/z suffix → in the y/z direction (i.e. $e_y = M_{Ed,y} / V_{Ed}$) (b) par suffix → eccentricity parallel to slab edge due to a moment about an axis perpendicular to slab edge
f_{cd}	Design compressive strength of concrete
f_{ck}	Cylinder strength of concrete

f_{yk}	Characteristic tensile strength of reinforcement
f_{ywd}	Design strength of the punching shear reinforcement
$f_{ywd,ef}$	Effective design strength of the punching shear reinforcement
$g_{_}$	Distance of slab edge from column (with suffices a, b, D, L, y, z) – see section 8.1
h	slab depth
h_1	where slab depth varies across top of column, slab depth 1
h_2	where slab depth varies across top of column, slab depth 2
k	(1) Coefficient dependant on the ratio between the control dimensions c_1 and c_2 (Table 1) (with suffix y/z → relating to $M_{Ed,y}$ and $M_{Ed,z}$ respectively) NB. The k in (eq. 6.44) is determined by replacing c_1/c_2 in Table 1 with $c_1/(2c_2)$. (2) Coefficient depending on effective depth of slab (6.4.4(1)) (3) Coefficient determining distance between the outermost perimeter of shear reinforcement and the control perimeter at which shear reinforcement is no longer required, u_{out} (6.4.5(4))
k_1	According to NA to BS EN 1992-1-1, 6.4.4 (1)
l	effective length of wall resisting punching shear load
l_1	larger dimension of a rectangular slab opening
l_2	shorter dimension of a rectangular slab opening
l_3	the minimum distance between tangential lines defining the ineffective slab region due to an opening in the slab
l_y / l_z	location of opening centre relative to column centre
s_r	Radial spacing of shear studs
$s_{r,0}$	Radial distance to first shear stud from column face
s_t	maximum tangential spacing between outermost shear studs
t	wall thickness
u_0	Perimeter of loaded area at the column face
u_1	Basic control perimeter
u_1^*	Reduced basic control perimeter
u_{out}	The control perimeter at which shear reinforcement is not required
$u_{out,ef}$	The control perimeter a distance kd from the outermost perimeter of shear reinforcement for a cruciform rail layout
$V_{Ed,0}$	Design shear stress at the face of the column
$V_{Ed,1}$	Design value of the shear stress at the basic control perimeter
$V_{Rd,c}$	Design value of the punching shear resistance at the basic control perimeter of the slab without shear reinforcement
$V_{Rd,cs}$	Design value of the punching shear resistance at the basic control perimeter of the slab with shear reinforcement
$V_{Rd,0,max}$	Design value of the maximum punching shear resistance at the loaded face
$V_{Rd,c,max}$	The maximum limiting value of the punching shear capacity of the slab
y	column dimension parallel to y-axis
y_0	co-ordinate of the u_1 centroid relative to the column centroid in the y-direction
y'	dimension of rectangular slab opening parallel to y-axis
z	column dimension parallel to z-axis
z_0	co-ordinate of the u_1 centroid relative to the column centroid in the z-direction
z'	dimension of rectangular slab opening parallel to z-axis

1.3 Greek Lower Case

α	Angle between shear reinforcement and the slab
α_{cc}	Coefficient taking account of long term effects taken as 1.0
β	Eccentricity factor
γ_s	Partial safety factor for the steel
γ_c	Partial safety factor for concrete
v	Strength reduction factor for cracked concrete in shear
σ_{cp}	Compressive stress in the concrete due to the axial load
σ_{cy}	Concrete stress at the critical section in y direction
σ_{cz}	Concrete stress at the critical section in z direction
ρ_l	Reinforcement ratio
ρ_{ly}	Reinforcement ratio in the y direction
ρ_{lz}	Reinforcement ratio in the z direction

2 References

BS EN 1992-1-1:2004+A1:2014, Eurocode 2: Design of concrete structures – Part 1-1: General rules and rules for buildings

NA+A2:2014 to BS EN 1992-1-1:2004+A1:2014, UK National Annex to Eurocode 2: Design of concrete structures – Part 1-1: General rules and rules for buildings

3 Introduction

Shear reinforcement is used within a slab or foundation around a column to prevent punching shear failure. Ancon Shearfix is the ideal solution to the design and construction problems associated with punching shear.

The Ancon Shearfix system comprises double-headed studs welded to a pair of flat rails. It is manufactured to suit the specific requirements of each application. The quantity of each component, the dimensions and spacing, and the layout pattern around the column are determined by calculation. LeviaT provides free software to determine the optimum system design.

Studs are manufactured from high strength steel bar with a characteristic yield strength of 500 N/mm². In the UK, four diameters are available (10, 12, 16 and 20mm); in Australia, four diameters are available (12, 16, 20 and 24mm). The heads are hot forged to three times the diameter of the bar. Studs are manufactured to virtually any length to suit the depth of the slab, but in the UK they are normally formed in increments of 5mm within the 100-1000mm range, and in Australia they are normally formed in increments of 10mm within the 100-500mm range.

The studs are welded to the rails at spacings determined by our software or design calculation. The rail performs no structural function but ensures stud alignment and positioning within the slab.

The rails are manufactured from strips of steel, typically 20mm wide, reducing to 16mm wide for 10, 12 and 16mm diameter studs in the UK. The gap between the strips allows for passage of concrete during pouring and also enables the rail to be nailed through spacers to formwork when fixed 'bottom up' i.e. prior to other reinforcement.

Ancon Shearfix is a proven system, which has undergone independent mechanical and structural testing. It has been approved by CARES for use in reinforced concrete slabs designed in accordance with EC2 design standard.

We are pleased to offer this Design Manual which demonstrates our expertise in the field of punching shear reinforcement to EC2.

The design method for Shearfix punching shear reinforcement is based on section 6.4 of BS EN 1992-1-1:2004, and is outlined within this Design Manual. The supporting Shearfix software reflects this method.

This Design Manual and the Shearfix program accommodate some column shapes and locations and some design options which are not specifically addressed by the Eurocode. BS EN 1992-1-1:2004 does not include oval columns or columns at re-entrant corners. LeviaT has drawn upon the principles presented in the BS EN 1992-1-1:2004, the expert advice of Professor Regan and verification testing that was carried out by us at Cambridge University with Professor Regan in March 2012. Furthermore, BS EN 1992-1-1:2004 does not include dimensional limits for the spread of punching shear stresses around the control perimeters of large and elongated columns. We have drawn upon the principles presented in Model Code 2010 and recent research findings to develop a "Best Practice" design option when dealing with large and elongated columns, whilst an "EC2" design option (which adheres to the rules of BS EN 1992-1-1:2004) is also provided.

4 Design Information and Assumptions

4.1 Information required

The following information is required in order to design the punching shear reinforcement:

- Column shape (rectangular, circular, oval)
- Column location (interior, edge, corner, re-entrant corner, wall end, wall corner)
- Column dimensions
- Distances to slab edges
- Slab properties (thickness, concrete strength, cover to main reinforcement)
- Diameter and spacing of tension reinforcement in both directions within $3d$ from the column face; or mean effective depth of tension reinforcement and reinforcement ratios in both directions
- The ultimate design load, V_{Ed} , and ultimate design moments, $M_{Ed,y}$ and $M_{Ed,z}$; or, the ultimate design load, V_{Ed} , and the appropriate β factor to be applied (see section 10)
- Location and size of any opening(s) within $6d$ from the column face

4.2 Design Assumptions

The following assumptions have been made in line with guidance within EC2:

- The minimum slab thickness is 200mm
- The minimum column dimension is 155mm
- The loads and moments entered have been factored in accordance with the Eurocodes
- The loads do not include the loads from the column above
- The concrete slab is to be constructed from normal weight concrete
- The reinforcement is detailed and installed as set out in EC2

4.3 Software Defaults

Column location	Internal	Openings	None
Column shape	Rectangular	(add rectangular) $\rightarrow l_y$	500 mm
Dimension, y	500 mm	(add rectangular) $\rightarrow l_z$	500 mm
Dimension, z	300 mm	(add rectangular) $\rightarrow y'$	400 mm
Dimension, D	500 mm	(add rectangular) $\rightarrow z'$	600 mm
Slab depth, h	250 mm	(add circular) $\rightarrow l_y$	500 mm
Concrete grade	C20/25	(add circular) $\rightarrow l_z$	500 mm
Top cover, $C_{nom,t}$	25 mm	(add circular) $\rightarrow \emptyset$	500 mm
Top cover, $C_{nom,b}$	25 mm	Shearfix layout	Auto
Reinforcement	None	Shearfix stud diameter	Auto
(add) \rightarrow Bar diameter	8 mm	Large and elongated columns	Best Practice
(add) \rightarrow Spacing	150 mm	Include distribution rails	Yes
Eccentricity factor, β	Calculated	Rail placing	Bottom-up
Shear load, V_{Ed}	500 kN	Distance to first stud	0.5d
Moment, $M_{Ed,y}$	0 kNm		
Moment, $M_{Ed,z}$	0 kNm		

5 Slab depth, h

The software can accommodate a step in slab depth. This step can be parallel to the y-axis or parallel to the z-axis and it can occur on the top or bottom surface of the slab. It may be located anywhere within the column width.

The smaller slab depth is applied to all shear capacity calculations. Both slab depths are applied to stud height calculations, such that some rails comprise of short studs for the thinner portion of slab and other rails comprise of tall studs for the thicker portion of slab. The shear studs in one rail are all the same height.

6 Effective depth, d

The effective depth of the reinforcement is the mean effective depth of all layers of reinforcement present. The equations below assume there are two layers of reinforcement in each direction in the order illustrated. If this is not the case, the equations need to be adapted accordingly. (The Shearfix software can accommodate up to two layers of reinforcement in each direction.)

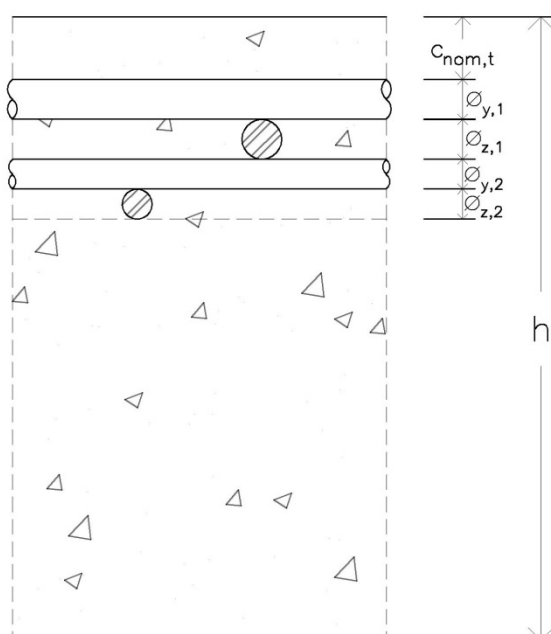

$$d = 0.25(d_{y,1} + d_{z,1} + d_{y,2} + d_{z,2})$$

where

$$d_{y,1} = h - c_{nom,t} - \frac{\phi_{y,1}}{2}$$

$$d_{z,1} = h - c_{nom,t} - \phi_{y,1} - \frac{\phi_{z,1}}{2}$$

$$d_{y,2} = h - c_{nom,t} - \phi_{y,1} - \phi_{z,1} - \frac{\phi_{y,2}}{2}$$

$$d_{z,2} = h - c_{nom,t} - \phi_{y,1} - \phi_{z,1} - \phi_{y,2} - \frac{\phi_{z,2}}{2}$$

Equation 1 Calculation of the effective depth of the slab, d

Where there is a step in the slab depth, the lesser of the two depths is used in the above equations.

Figure 1 Reinforcement in the slab

7 Reinforcement ratio, ρ

The reinforcement ratio of the slab is calculated as follows:

$$\rho_l = \sqrt{\rho_{ly} \times \rho_{lz}} \leq 0.02$$

Where:
$$\rho_{ly} = \frac{A_{sy}}{A_c} = \frac{A_{sy,1}}{d_{y,1}} + \frac{A_{sy,2}}{d_{y,2}} \quad \text{and} \quad \rho_{lz} = \frac{A_{sz}}{A_c} = \frac{A_{sz,1}}{d_{z,1}} + \frac{A_{sz,2}}{d_{z,2}}$$

Equation 2 Calculation of the slab reinforcement ratio, based on BS EN 1992-1-1:2004, 6.4.4 (1)

For the purpose of this calculation, the units for the area of tensile slab reinforcement, A_s , are mm^2/mm width of slab. The area of concrete, A_c , mm^2/mm width of slab is equal to the effective depth of the reinforcement, d (mm^2), multiplied by a 1mm strip width of slab.

8 Column and edge dimensions

There are varying schools of thought regarding the column perimeter length effective in resisting punching shear. The only limit in the current Eurocode is the aspect ratio which differentiates a column from a wall, 1:4 (BS EN 1992-1-1:2004+A1:2014, 9.5.1). However, research suggests that punching shear stresses in the slab are focused at the corners of columns. The larger a column is the more significant this effect. To accommodate these two schools of thought, we have developed two design options for dealing with large and elongated columns: “EC2” and “Best Practice”.

For both approaches, the length to breadth ratio of rectangular and oval columns is limited to 4:1. There is no limit to the control perimeters of a circular column or to the curved faces of an oval column. In the Best Practice approach, an additional rule is imposed limiting the control perimeters to a distance of 1.5d from the corners of rectangular columns and from the point of transition between the straight and curved faces of an oval column. The Best Practice approach is in accordance with fib Model Code 2010 and the research paper, “Study on Influence of Column Size and Slab Slenderness on Punching Strength” (Einpaal, J., Bujnak, J., Fernandez Ruiz, M. and Muttoni, A. (2016), *ACI Structural Journal*, V. 113, No. 1, pp. 135-146).

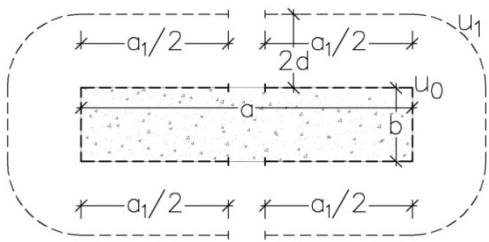
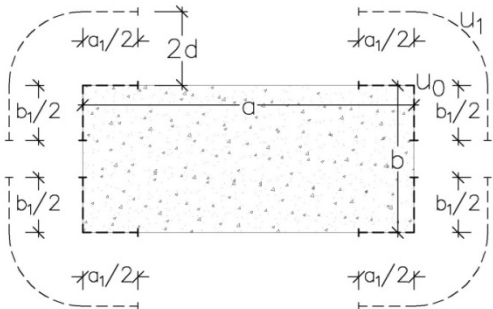
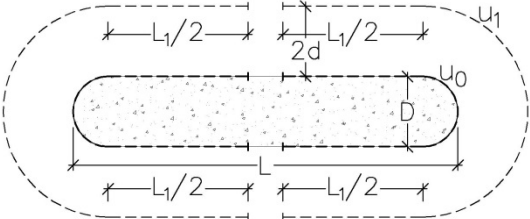
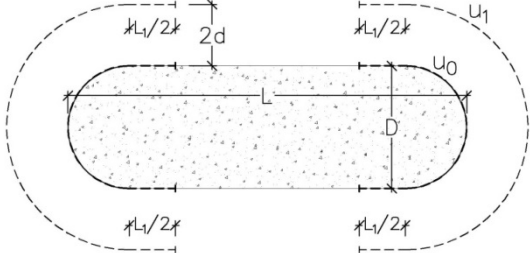
“EC2”	“Best Practice”
 <p>Where: $a_1 = \min(a, 4b)$ $u_0 = 2a_1 + 2b$ $u_1 = 2a_1 + 2b + 4\pi d$</p>	 <p>Where: $a_1 = \min(a, 4b, 3d)$ $b_1 = \min(b, 3d)$ $u_0 = 2a_1 + 2b_1$ $u_1 = 2a_1 + 2b_1 + 4\pi d$</p>
 <p>Where: $L_1 = \min(L - D, 3D)$ $u_0 = 2L_1 + \pi D$ $u_1 = 2L_1 + \pi(D + 4d)$</p>	 <p>Where: $L_1 = \min(L - D, 3D, 3d)$ $u_0 = 2L_1 + \pi D$ $u_1 = 2L_1 + \pi(D + 4d)$</p>

The Eurocode notation for column dimensions (c_1, c_2) is dependent on the direction of the applied load. For design simplicity, the program input (and the notation of this design manual) relates to the directions of the y and z axes. EC2 notation is translated accordingly.

8.1 Edge dimensions

The Shearfix program requires entry of the distances between column faces and slab edges in the y- and z-directions, $a_{e,y}$ and $a_{e,z}$. For calculations, these are translated into edge distances g_a , g_b , g_L , g_D , g_y or g_z as appropriate. The relationships between these dimensions are illustrated in Figure 2.

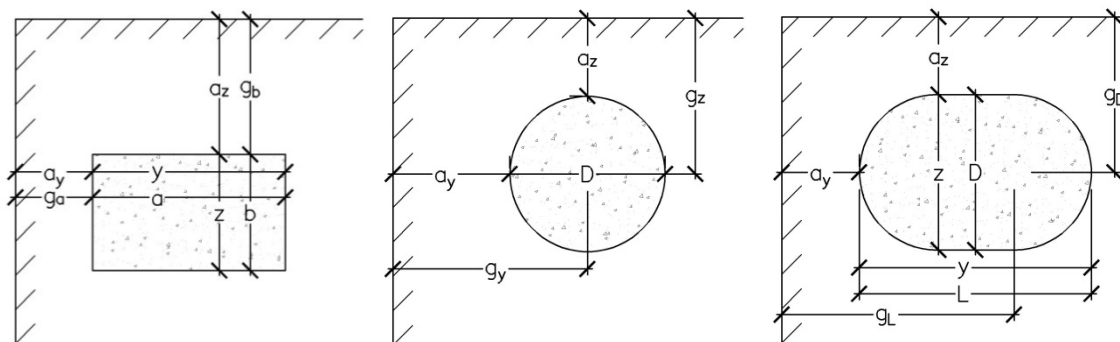
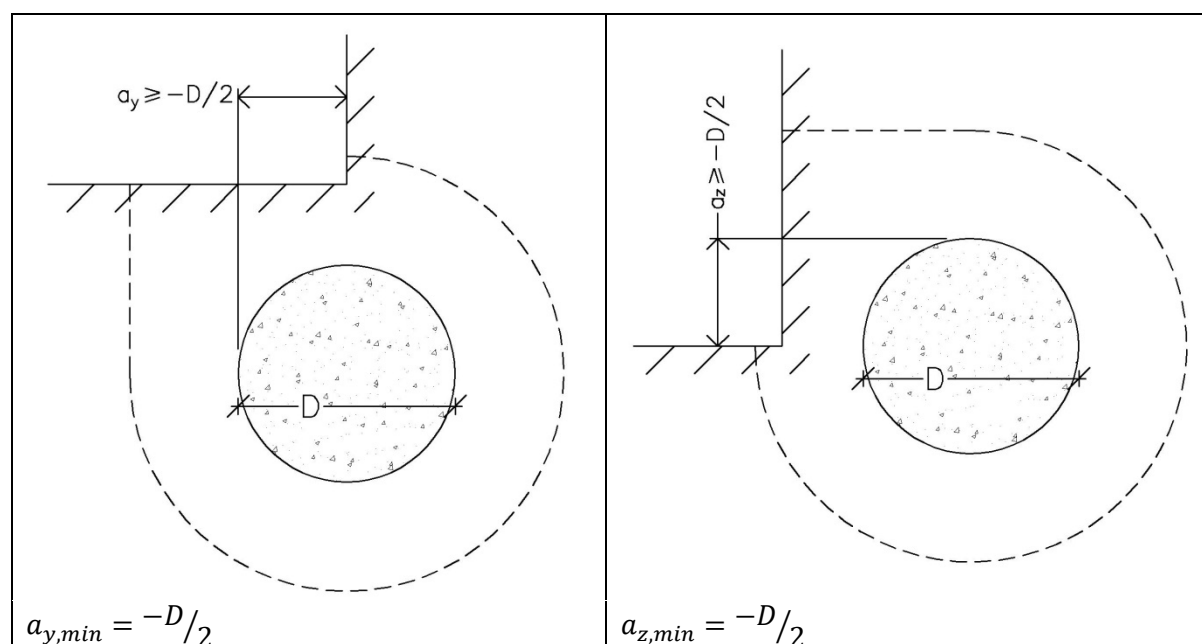

Figure 2 Edge dimensions

- $a_{e,y}$ distance between column face and slab edge parallel to y-axis (labelled a_y in diagrams)
- $a_{e,z}$ distance between column face and slab edge parallel to z-axis (labelled a_z in diagrams)
- g_a distance between column face and slab edge parallel to dimension a of column
- g_b distance between column face and slab edge parallel to dimension b of column
- g_y distance between column centre and slab edge parallel to y-axis
- g_z distance between column centre and slab edge parallel to z-axis
- g_L distance between slab edge and further radial centre of oval column parallel to dimension L
- g_D distance between column centre and slab edge parallel to dimension D

8.2 Edge dimension limits

For re-entrant corners in the Shearfix software, the edge distances are limited. In the following sketches, the columns are drawn at the maximum permitted distance from the re-entrant corner.



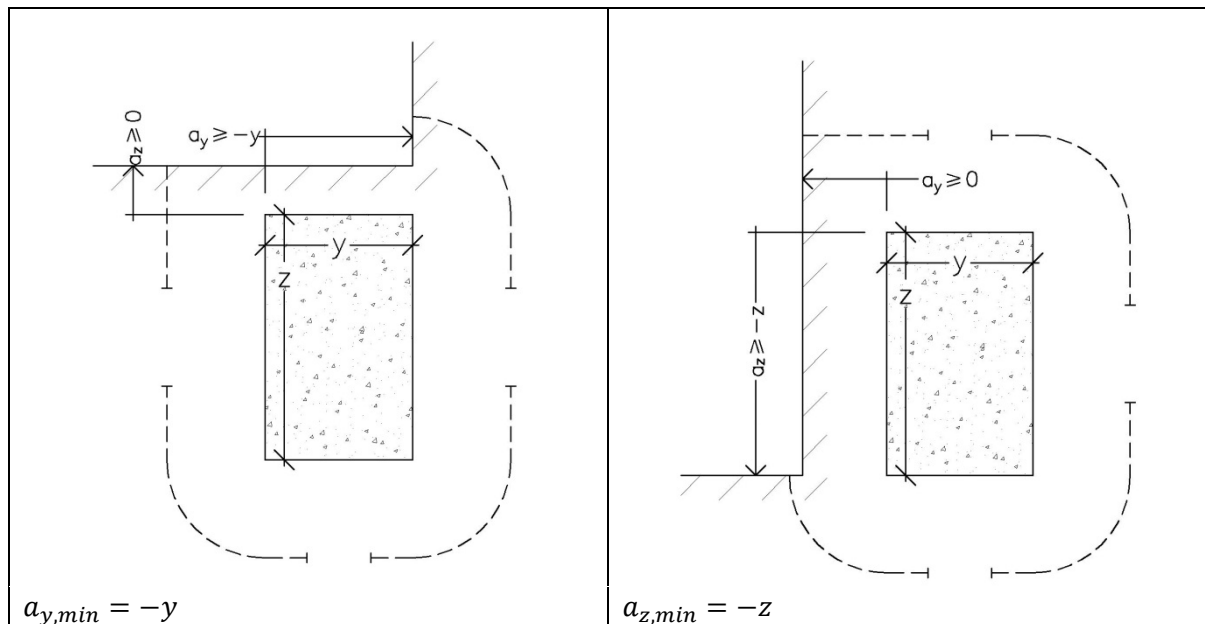

9 Column locations and virtual slab openings

The design approach allows for the user-defined column location to be automatically overridden if another location is more appropriate. The shortest possible basic control perimeter determines the column location.

This approach follows from BS EN 1992-1-1:2004 6.4.2 (4), “For a loaded area situated near an edge or a corner, the control perimeter should be taken as shown in [Figure 3 below], if this gives a perimeter (excluding the unsupported edges) smaller than that obtained from [Figure 4 below].”

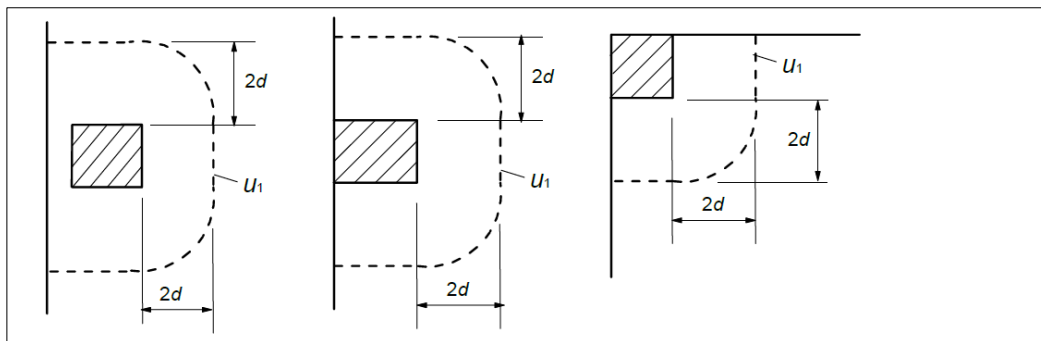

Figure 3 BS EN 1992-1-1:2004, Figure 6.15 Basic control perimeters for edge and corner columns

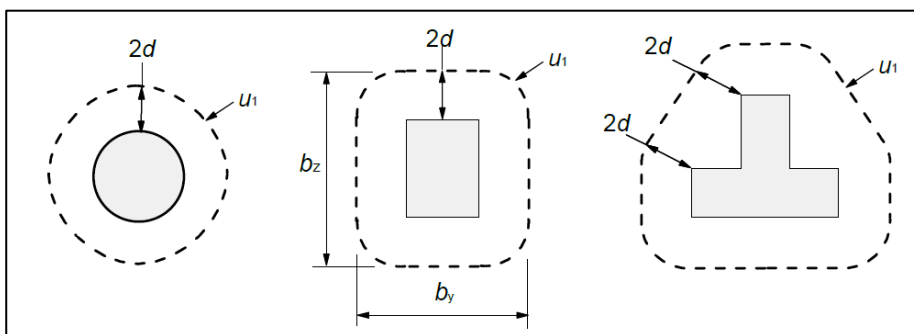

Figure 4 BS EN 1992-1-1:2004, Figure 6.13 Typical basic control perimeters around loaded areas

If a slab edge is located within a distance of $6d$ from the column face and is not accounted for in the determined column location, then it is considered as a virtual opening in the slab. The size of a virtual opening is determined as shown in the following example.

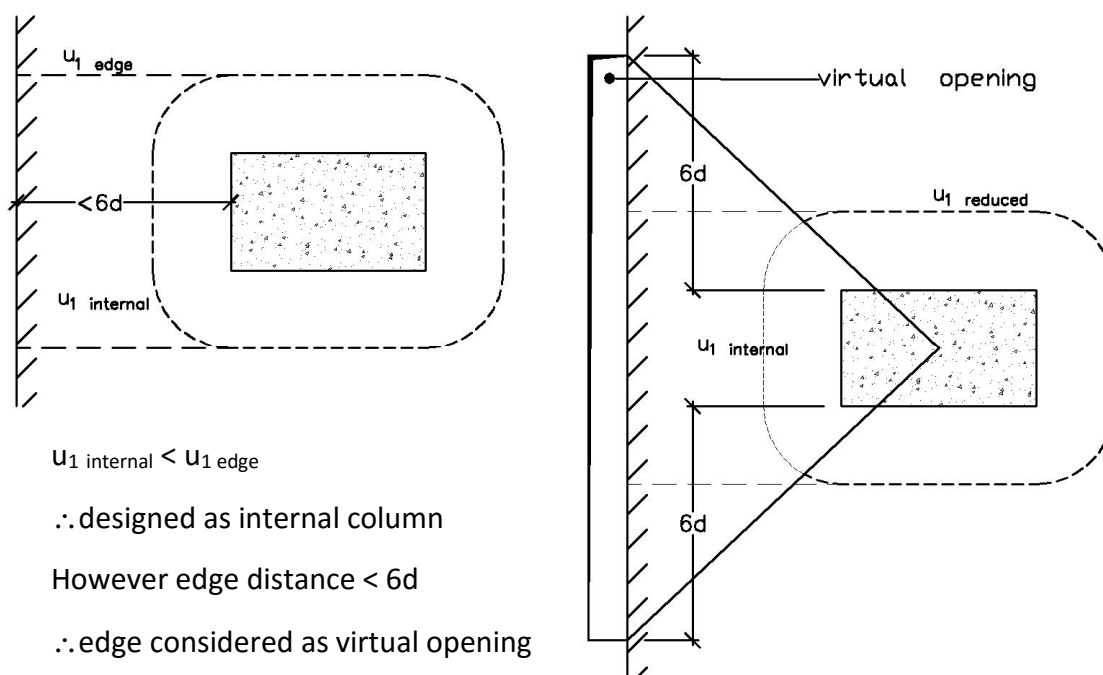

Figure 5 User-defined edge column designed as internal column with virtual opening at slab edge

10 Eccentricity factor β

The recommended approach for determining the eccentricity factor β is to use equations in section 6.4.3 parts (3)-(5) in EC2, based on the geometry and applied moments, referred to as “calculated” in the software.

The Eurocode presents one equation (6.39) which is applicable to all columns types. The Eurocode also presents a series of other equations each of which is applicable to a specific scenario. Our approach is to calculate the β -value according to the general formula (Equation 3) and according to a specific scenario formula where applicable. The greater of these two values is then adopted as the β value. A minimum value of $\beta = 1.0$ is applied to all column shapes and locations.

In version 5.10 onwards, the software has been modified such that the u_1^* parameter accounts for reductions due to slab openings. Accordingly, in the β calculation, the u_1 value also accounts for reductions due to slab openings where the u_1 value relates to the u_1^* value; and, the u_1 value does not account for reductions due to slab openings where the u_1 value relates to the W_1 factor.

Alternatively to the calculated approach, the user may input a β value they have calculated independently or a β value provided in Figure 6. The latter are referred to as “recommended” values in EC2 and as “default” values in the Shearfix program. The values in Figure 6 must only be used for structures where the adjacent slabs do not differ in length by more than 25% and where the lateral stability does not depend on frame action between the slabs and the columns. (Please note there is no recommended / default value for a re-entrant corner location.)

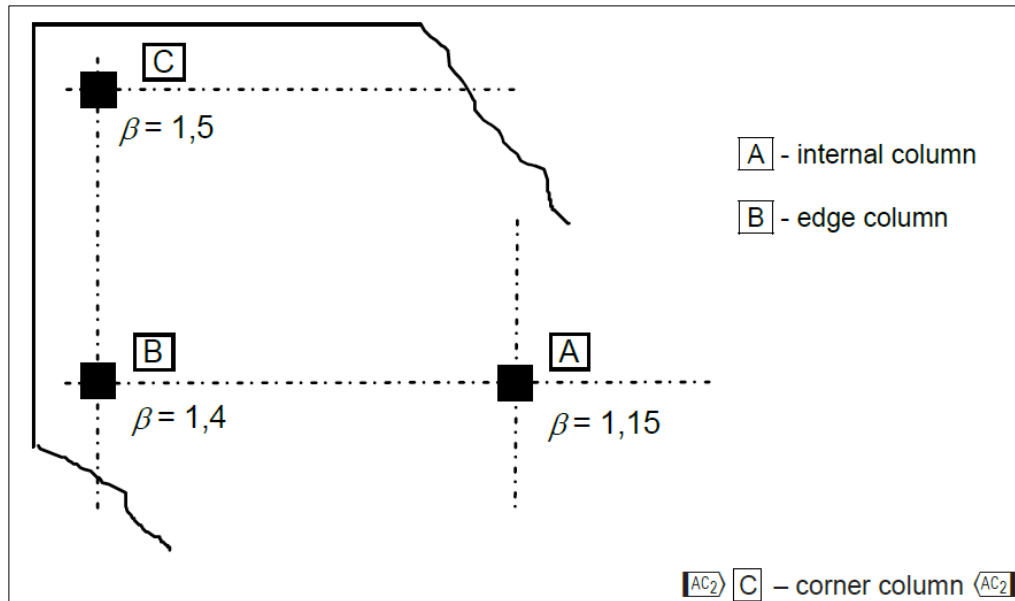

Figure 6 BS EN 1992-1-1:2004, Figure 6.21N Recommended values for β

10.1 General formula for β values

The general formula for calculating the β -value is a re-arranged version of equation (6.39) from BS EN 1992-1-1:2004.

$$\beta = 1 + k \frac{M'_{Ed} u_1}{V_{Ed} W_1}$$

Equation 3 General formula for beta-value adapted version of eq. (6.39)

Where,

- k = coefficient relative to appropriate axes (See Table 1)
- M'_{Ed} = design moment about centroid of basic control perimeter (See Section 11.1)
- V_{Ed} = design shear force
- u_1 = basic control perimeter (See Table 3)
- W_1 = property of basic control perimeter relative to appropriate axes (See Section 11.3)

The k value is taken from the following table. Linear interpolation is assumed between stated values.

For circular columns, $k = 0.6$

c_1/c_2	$\leq 0,5$	1,0	2,0	$\geq 3,0$
k	0,45	0,60	0,70	0,80

Table 1 BS EN 1992-1-1:2004, Table 6.1 Values of k for rectangular loaded areas

10.2 Internal column with biaxial moments

$$\beta = 1 + 1.8 \sqrt{\left(\frac{e_y}{b_z}\right)^2 + \left(\frac{e_z}{b_y}\right)^2}$$

Equation 4 BS EN 1992-1-1:2004 (6.43), β for internal rectangular column with biaxial moments

Where,

- e_y and e_z = eccentricities along y and z axes respectively
- b_y and b_z = dimensions of the control perimeter

Counter-intuitively,

$$e_y = \frac{M_{Ed,z}}{V_{Ed}} \quad \text{and} \quad e_z = \frac{M_{Ed,y}}{V_{Ed}}$$

Regardless of column size, $b_y = y + 4d$ and $b_z = z + 4d$

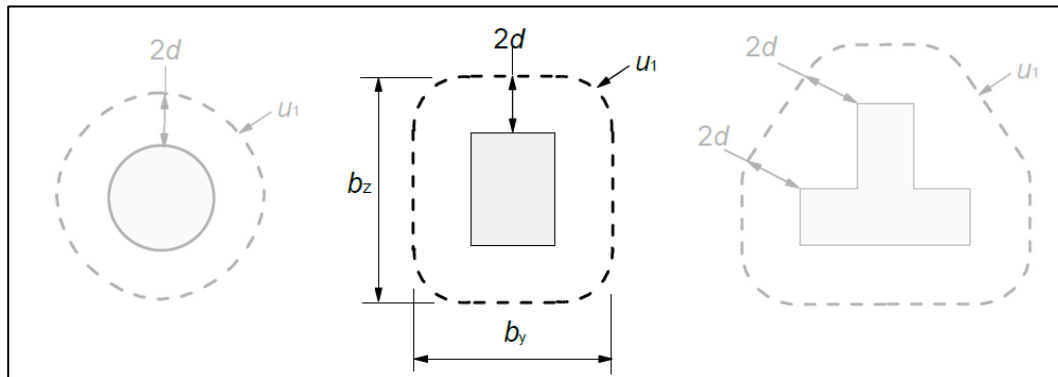

Figure 7 BS EN 1992-1-1:2004, Figure 6.13 Definition of b_y and b_z values

10.3 Edge column with moment towards interior of slab

This case applies to both edge columns and wall ends when the translated moment (acting about the centroid of the basic control perimeter) is towards the interior of the slab (see Section 11.1).

$$\beta = \frac{u_1}{u_1^*} + k \frac{u_1}{W_1} e_{par}$$

Equation 5 BS EN 1992-1-1:2004 eq. (6.44) β : edge column with loading towards interior of slab

Where,

- u_1 = basic control perimeter (Table 3)
- u_1^* = reduced basic control perimeter (Table 3)
- k = coefficient given in Table 1 with the ratio c_1/c_2 replaced by $c_1/2c_2$
- W_1 = property of basic control perimeter relative to axis perpendicular to slab edge (Section 11.3)
- e_{par} = eccentricity parallel to slab edge resulting from a moment about an axis perpendicular to slab edge

10.4 Corner column with moment towards interior of slab

This case applies to both corner columns and wall corners when the translated moment (acting about the centroid of the basic control perimeter) is towards the interior of the slab (see Section 11.1).

$$\beta = \frac{u_1}{u_1^*}$$

Equation 6 BS EN 1992-1-1:2004 eq. (6.46) β : edge column where eccentricity is towards interior

Where,

- u_1 = basic control perimeter (Table 3)
- u_1^* = reduced basic control perimeter (Table 3)

10.5 Default β -value

Where β cannot be calculated using the above formulae, the following values can be used. These values can only be used if the lateral stability of the structure does not depend on frame action between the slabs and the columns and if adjacent spans do not differ in length by more than 25%.

Column location	Default β -value, Figure (6.21N)
Internal	1.15
Edge or wall end	1.4
Corner or wall corner	1.5
Re-entrant corner	N/A

Table 2 BS EN 1992-1-1:2004 Figure 6.21N, Default ("Recommended") values for β

11 Parameters for calculating β -values

11.1 Translation of moments

In order to calculate the β value, the designer needs to provide the design moments applied to the column. These values are entered relative to the centre of the column, wall end or wall centre. (The "centre of a wall corner" is located at the centre of a square column of side dimension, l , where l is the effective length of the wall corner.) For the calculation of β , these are translated relative to the centroid of the basic control perimeter, u_1 . The Shearfix program calculates this automatically.

The notation used is as follows:

$M_{Ed,y}$ Design moment about axis y through centroid of column

$M_{Ed,z}$ Design moment about axis z through centroid of column

$M'_{Ed,y}$ Design moment about axis y through centroid of basic control perimeter

$M'_{Ed,z}$ Design moment about axis z through centroid of basic control perimeter

The sign convention is determined by the right-hand rule: a positive bending moment follows the direction of curled fingers on the right hand when the thumb is pointed in the positive axis direction.

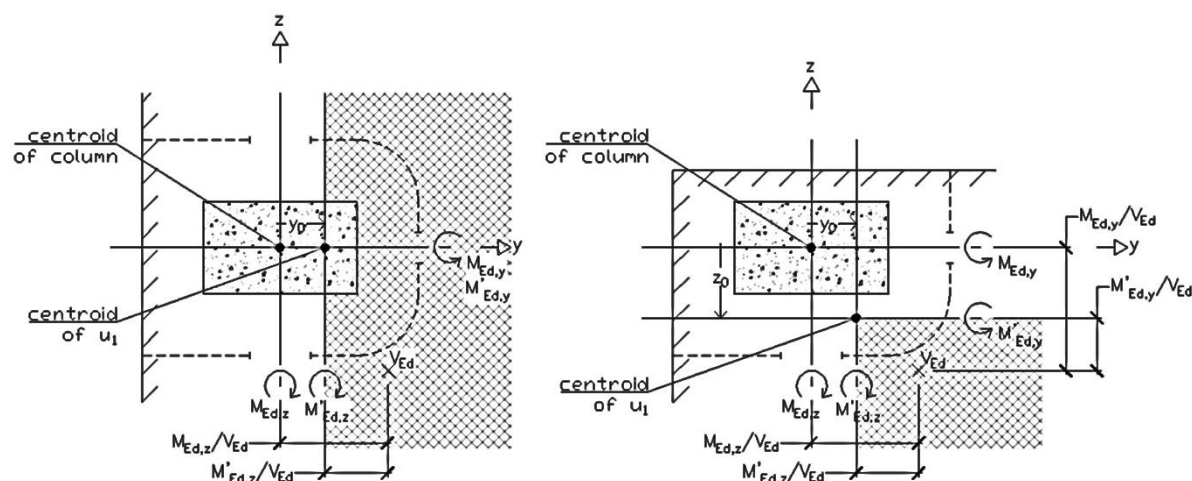

Figure 8 Translation of moment about column to moment about basic control perimeter

$$M'_{Ed,y} = M_{Ed,y} - z_0 V_{Ed} \quad \text{and} \quad M'_{Ed,z} = M_{Ed,z} - y_0 V_{Ed}$$

Equation 7 Translation of moment

where y_0 , z_0 , $M_{Ed,y}$ and $M_{Ed,z}$ are positive as illustrated in Figure 8.

11.2 Control perimeters

The column face control perimeters (u_0) are presented in the Eurocode as follows:

u_0	for an interior column	$u_0 = \text{enclosing minimum periphery [mm]}$
	for an edge column	$u_0 = c_2 + 3d \leq c_2 + 2c_1$ [mm]
	for a corner column	$u_0 = 3d \leq c_1 + c_2$ [mm]

Figure 9 BS EN 1992-1-1:2004, 6.4.5(3) column face perimeters

The basic control perimeters (u_1) for internal columns, and for edge and corner columns are presented in the Eurocode as follows:

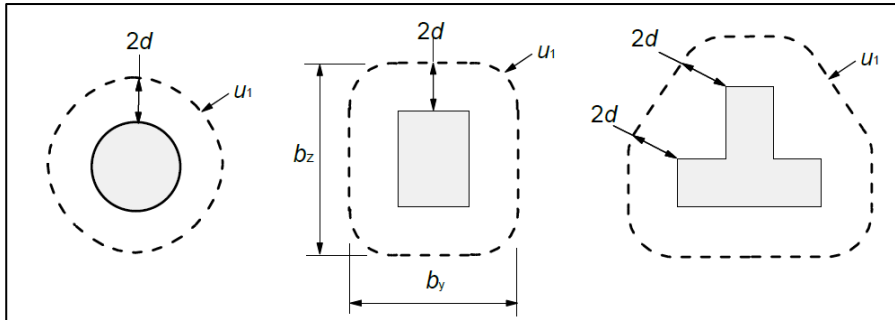

Figure 10 BS EN 1992-1-1:2004 Figure 6.13 Typical basic control perimeters around loaded areas

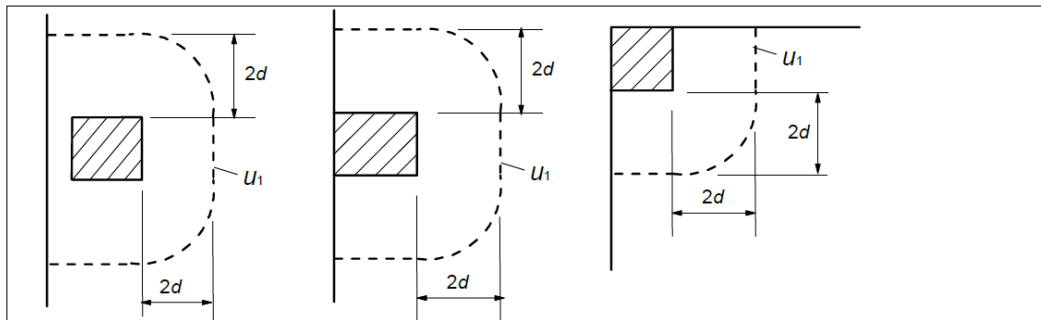

Figure 11 BS EN 1992-1-1:2004, Figure 6.15 Basic control perimeters for edge and corner columns

The reduced basic control perimeters (u_1^*) for edge and corner columns are presented in the Eurocode as follows:

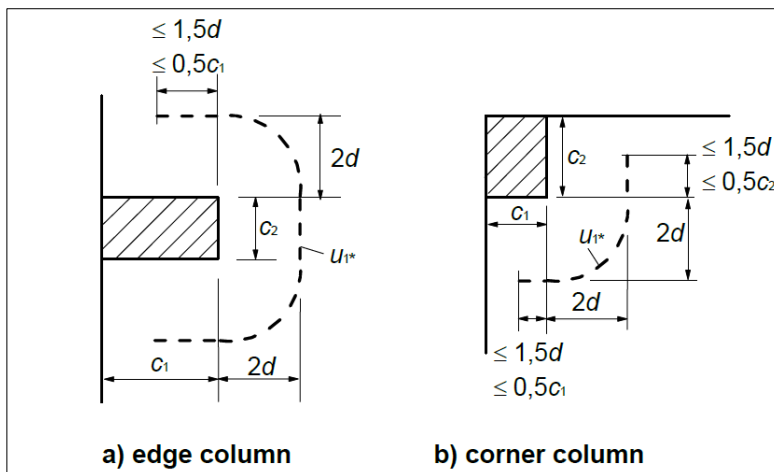

Figure 12 BS EN 1992-1-1:2004 Figure 6.20 Reduced basic control perimeter u_1^*

The control perimeter definitions (Table 3) are based on these figures and the application of effective dimensions as described in section 8 above. These definitions have been revised for Shearfix 5.7 to incorporate the “1.5d” and “3d” limits to u_0 and u_1^* values described above.

Column		Control perimeter		
Location	Shape	Column face, u_0	Basic, u_1	Reduced basic, u_1^*
Internal	Rectangular	$u_0 = 2a_1 + 2b_1$	$u_1 = 2a_1 + 2b_1 + 4\pi d$	N/A
	Circular	$u_0 = \pi D$	$u_1 = \pi(D + 4d)$	N/A
	Oval	$u_0 = 2L_1 + \pi D$	$u_1 = 2L_1 + \pi(D + 4d)$	N/A
Edge (equations depend on column orientation)	Rectangular	$u_0 = 2a_{1u0} + b_1$ $u_0 = a_1 + 2b_{1u0}$	$u_1 = 2a_1 + b_1 + 2g_a + 2\pi d$ $u_1 = a_1 + 2b_1 + 2g_b + 2\pi d$	$u_1^* = a_{1us} + b_1 + 2\pi d$ $u_1^* = a_1 + b_{1us} + 2\pi d$
	Wall end	$u_0 = 2l_{u0} + t$	$u_1 = 2l + t + 2\pi d$	$u_1^* = l_{us} + t + 2\pi d$
	Circular	$u_0 = 0.25\pi D + 2D_{u0}$	$u_1 = 0.5\pi(D + 4d) + 2g$	$u_1^* = 0.25\pi(D + 4d) + D_{us}$
	Oval	$u_0 = 2L_{1u0} + 0.5\pi D$ $u_0 = L_1 + 0.25\pi D + 2D_{u0}$	$u_1 = 2L_1 + 0.5\pi(D + 4d) + 2(g_L - L + D)$ $u_1 = L_1 + 0.5\pi(D + 4d) + 2g_D$	$u_1^* = 0.5\pi(D + 4d) + L_{1us}$ $u_1^* = 0.25\pi(D + 4d) + L_1 + D_{us}$
Corner	Rectangular	$u_0 = a_{1u0} + b_{1u0}$	$u_1 = a_1 + b_1 + g_a + g_b + \pi d$	$u_1^* = 0.5a_{1us} + 0.5b_{1us} + \pi d$
	Wall corner	$u_0 = 2l_{u0}$	$u_1 = 2l + \pi d$	$u_1^* = l_{us} + \pi d$
	Circular	$u_0 = 2D_{u0}$	$u_1 = 0.25\pi(D + 4d) + g_y + g_z$	$u_1^* = D_{us}$
	Oval	$u_0 = L_{1u0} + D_{u0} + 0.125\pi D$	$u_1 = L_1 + 0.25\pi(D + 4d) + g_L - L + D + g_D$	$u_1^* = 0.5L_{1us} + 0.5D_{us} + 0.125\pi(D + 4d)$
Re-entrant corner	Rectangular $g_a \geq 0, g_b \geq 0$	$u_0 = a_1 + b_1 + a_{1u0} + b_{1u0}$	$u_1 = 2a_1 + 2b_1 + g_a + g_b + 3\pi d$	N/A
	$g_a \geq 0, g_b < 0$	$u_0 = a_1 + b_1 + a_{1u0} + b_{2u0}$	$u_1 = 2a_1 + b_1 + b_2 + g_a + 3\pi d$	N/A
	$g_a < 0, g_b \geq 0$	$u_0 = a_1 + b_1 + a_{2u0} + b_{1u0}$	$u_1 = a_1 + 2b_1 + a_2 + g_b + 3\pi d$	N/A
	Circular	$u_0 = 0.5\pi D + 2D_{u0}$	$u_1 = 0.75\pi(D + 4d) + g_y + g_z$	N/A

Table 3 Control perimeters u_0 , u_1 and u_1^* (see Table 4 & Table 5 below for parameter definitions)

Column shape	Parameter	Best Practice	EC2	
rectangular	a	Max (y, z)		
	b	Min (y, z)		
	a ₁	Min (a, 4b, 3d)	Min (a, 4b)	
	a _{1u0}	Min (a, 4b, 1.5d)		
	a _{1us}	Min (a, 4b, 3d)		
	b ₁	Min (b, 3d)	b	
	b _{1u0}	Min (b, 1.5d)		
	b _{1us}	Min (b, 3d)		
	a ₂	Min (a+g _a , 2b, 1.5d)	Min (a+g _a , 2b)	
	a _{2u0}		Min (a+g _a , 2b, 1.5d)	
	b ₂	Min (b+g _b , 1.5d)	b+g _b	
	b _{2u0}		Min (b+g _b , 1.5d)	

Table 4 Control perimeter parameters

Column shape	Parameter	Best Practice	EC2
oval & circular	L	Max (y, z)	
	D	Min (y, z)	
	L ₁	Min (L-D, 3D, 3d)	Min (L-D, 3D)
	L _{1u0}	Min (L-D, 3D, 1.5d)	
	L _{1us}	Min (L-D, 3D, 3d)	
	D _{u0}	Min (0.25πD, 1.5d)	
	D _{us}	Min (0.25π(D+4d), 3d)	
	walls	l	l _{auto} or l _{user} (whichever is selected)
l _{user}		User input value	
l _{auto}		Min (2t, 1.5d)	2t
l _{u0}		Min (2t, 1.5d)	
l _{us}		Min (2t, 3d)	

	Distance parallel to...		Distance parallel to...
g _a	dimension a from column face to slab edge	g _b	dimension b from column face to slab edge
g _D	dimension D from centre of column to slab edge	g _L	dimension L from the further radial centre of column to slab edge
g _y	y-axis from centre of column to slab edge	g _z	z-axis from centre of column to slab edge
g = g _y or g _z , as appropriate			
For accompanying diagrams, see 8.1 Edge dimensions on page 11			

Table 5 Edge distance parameters

11.3 W_1 values

The W_1 value is a shear distribution factor. It is a function of the basic control perimeter. It is the integral of the length of the basic control perimeter by its distance from the centroidal axis.

$$W_i = \int_0^{u_i} |e| dl$$

Equation 8 BS EN 1992-1-1:2004 eq. (6.40) Definition of W_i as a function of a control perimeter

Where, dl = length increment of the perimeter
 e = distance of dl from the axis about which the translated moment M'_{Ed} acts

This integral has been calculated for two column scenarios which are both presented in the Eurocode. The first scenario is a “small” rectangular internal column. “Small” means that the effective column dimensions are equal to the actual column dimensions, i.e. $a_1 = a$ and $b_1 = b$.

$$W_1 = 0.5c_1^2 + c_1c_2 + 4c_2d + 16d^2 + 2\pi dc_1$$

Equation 9 BS EN 1992-1-1:2004 eq. (6.41), W_1 formula for internal rectangular column

The second applies to a “small” rectangular column at a slab edge where the load eccentricity parallel to the slab edge is zero.

$$W_1 = 0.25c_2^2 + c_1c_2 + 4c_1d + 8d^2 + \pi dc_2$$

Equation 10 BS EN 1992-1-1:2004 eq. (6.45), W_1 formula when $a_1 = a$, $b_1 = b$ and edge distance = 0

For all scenarios, the W_1 value is automatically calculated by the Shearfix software.

12 Slab openings

For columns situated near openings, if the shortest distance from the column face to the edge of the opening does not exceed $6d$, that part of the control perimeter contained between two tangents drawn to the outline of the opening from the column centre is considered ineffective. (BS EN 1992-1-1:2004 6.4.2 (3)). This leads to reduced effective control perimeters (u_0 , u_1 , u_1^* and u_{out}) which are applied to the β calculations, shear stress calculations and the layout of punching shear reinforcement.

For rectangular openings, the two tangential lines must be a minimum distance apart. This minimum distance is measured at the corner of the opening which sets out the position of a tangential line and is closest to the column. This minimum distance is: $l_3 \geq \sqrt{l_1 \times l_2}$ where l_1 is the larger slab opening dimension and l_2 is the lesser slab opening dimension. (See Figure 13.) There is no equivalent minimum distance for circular openings.

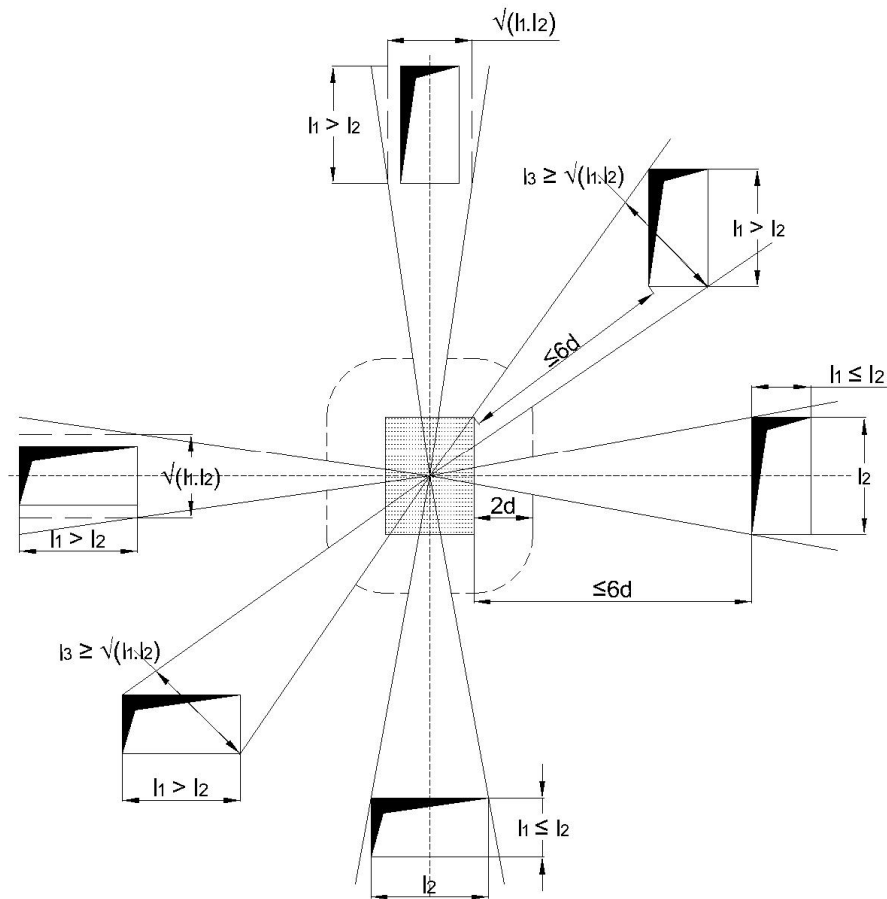
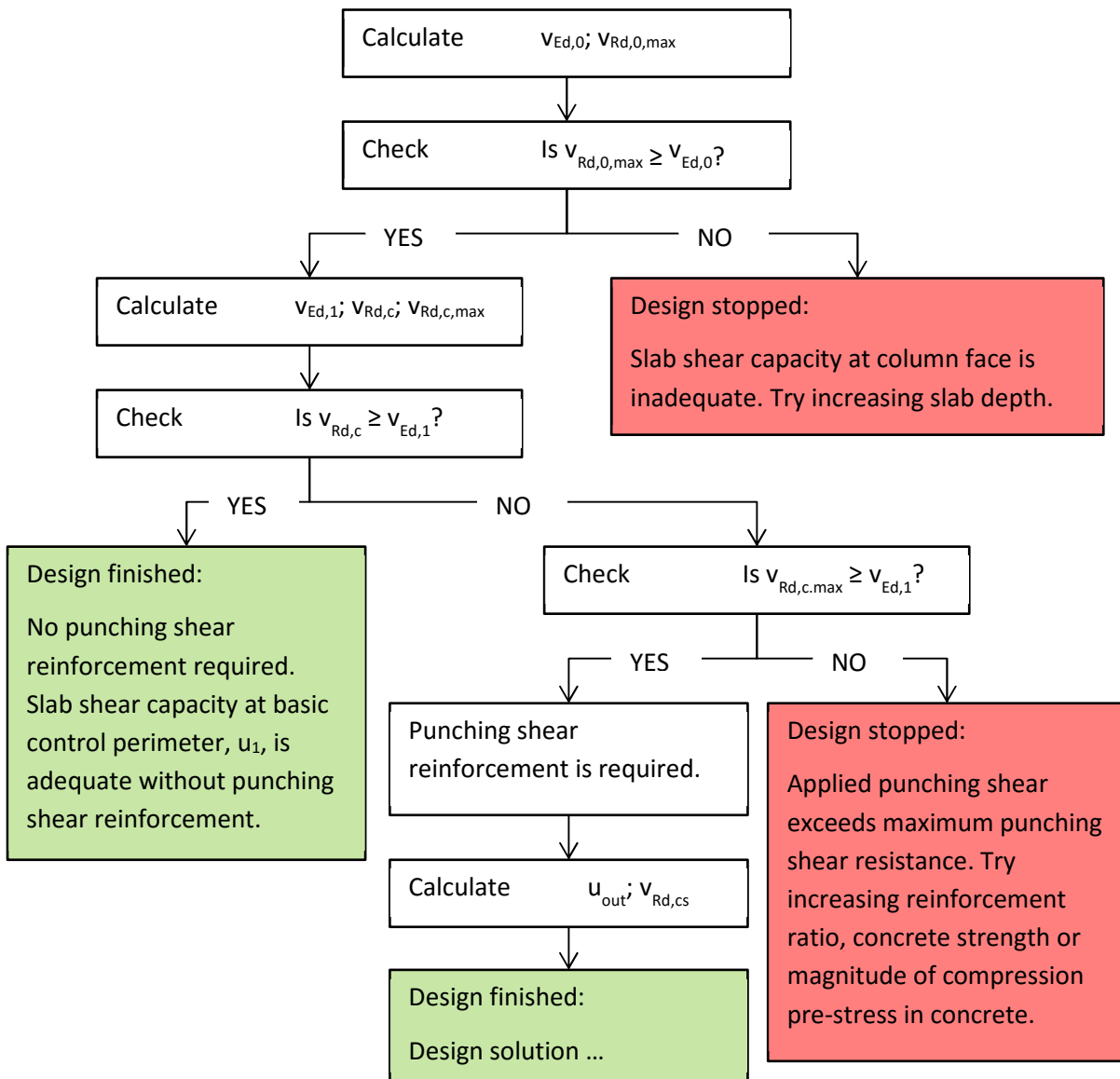

Figure 13 Control perimeter near openings, developed from BS EN 1992-1-1:2004 Figure 6.14

13 Shear stress calculations

The design procedure is described in the following flowchart:



For the purpose of these calculations,

u_0 [mm] the column face control perimeter accounting for reductions due to slab openings

u_1 [mm] the basic control perimeter accounting for reductions due to slab openings

The shear stresses are calculated as follows. (All references relate to BS EN 1992-1-1 or its national annex.)

The applied design shear stress at the column face, $v_{Ed,0} = \frac{\beta V_{Ed}}{u_0 \times d} \leq v_{Rd,max}$ [MPa] eq. (6.53)

where β = the eccentricity factor (Section 10)

V_{Ed} = the applied design shear force [N]

u_0 = the column face control perimeter accounting for reductions due to slab openings (Table 3 and Section 12) [mm]

d = slab effective depth (Section 5) [mm]

The maximum shear capacity at the column face, $v_{Rd,max} = 0.5vf_{cd}$ [MPa] (NA 6.4.5 (3))

where strength reduction factor, $v = 0.6 \left(1 - \frac{f_{ck}}{250}\right)$ NA 6.2.2 (6)

f_{ck} = cylinder strength of concrete (MPa)

design compressive strength, $f_{cd} = \alpha_{cc}f_{ck}/\gamma_c$ [MPa] eq. (3.15)

coefficient taking account of long term effects, $\alpha_{cc} = 1$ NA 3.1.6 (1)

partial safety factor for concrete, $\gamma_c = 1.5$ Table 2.1N (NA 2.4.2.4(1))

The applied design shear stress at the basic control perimeter, $v_{Ed,1} = \frac{\beta V_{Ed}}{u_1 \times d}$ (MPa) eq. (6.38)

where u_1 = the basic control perimeter accounting for reductions due to slab openings (determined using Table 3 and section 12) [mm]

The shear capacity without punching shear reinforcement,

$$v_{Rd,c} = C_{Rd,c}k(100\rho_l f_{ck})^{1/3} + k_1\sigma_{cp} \geq (v_{min} + k_1\sigma_{cp}) \quad \text{eq. (6.47)}$$

where $C_{Rd,c} = 0.18/\gamma_c$ NA 6.4.4 (1)

partial safety factor for concrete, $\gamma_c = 1.5$ Table 2.1N (NA 2.4.2.4(1))

$$k = 1 + \sqrt{\frac{200}{d}} \leq 2.0 \quad 6.4.4 (1)$$

ρ_l = reinforcement ratio (Section 7)

$k_1 = 0.1$ NA 6.4.4 (1)

$$\sigma_{cp} = (\sigma_{cy} + \sigma_{cz})/2 \quad 6.4.4 (1)$$

normal concrete stresses in the critical section in y- and z-directions (MPa, positive in

compression), $\sigma_{cy} = \frac{N_{Ed,y}}{A_{cy}}$ and $\sigma_{cz} = \frac{N_{Ed,z}}{A_{cz}}$ 6.4.4 (1)

$N_{Ed,y}$, $N_{Ed,z}$ = longitudinal forces across the critical section from a load or prestressing action.

[N] 6.4.4 (1)

A_c = area of concrete according to the definition of N_{Ed} [mm²] 6.4.4 (1)

$$v_{min} = 0.035k^{3/2}f_{ck}^{1/2} \quad \text{NA 6.4.4 (1)}$$

The maximum limiting value of punching shear capacity, $v_{Rd,c,max} = 2 \times v_{Rd,c}$ NA 6.4.5(1)

If it is determined that punching shear reinforcement is required. The layout of that reinforcement is determined using Section 15.

The extent of that reinforcement is determined by calculating the length of the control perimeter at which punching shear reinforcement is no longer required:

$$u_{out} = \frac{\beta V_{Ed}}{v_{Rd,c} \times d} \quad \text{eq. (6.54)}$$

The outer perimeter of shear studs must be within a distance of 1.5d from that perimeter. The shape of the outer control perimeter u_{out} is dependent on the arrangement of shear reinforcement, effective column dimensions and ineffective regions due to slab openings.

The shear capacity with punching shear reinforcement, $v_{Rd,cs} = 0.75v_{Rd,c} + 1.5\left(\frac{d}{s_r}\right)A_{sw}f_{ywd,ef}\left(\frac{1}{u_1d}\right)\sin\alpha$ eq. (6.52)

This equation is rearranged to determine the area of punching shear reinforcement required per perimeter around the column,

$$A_{sw} = \frac{(v_{Ed,1} - 0.75v_{Rd,c})s_r u_1}{1.5f_{ywd,ef}}$$

where s_r = radial spacing of perimeters of shear reinforcement [mm]

effective design strength of punching shear reinforcement,

$$f_{ywd,ef} = 250 + 0.25d \leq f_{ywd} \text{ [MPa]} \quad 6.4.5(1)$$

design yield strength of punching shear reinforcement, $f_{ywd} = f_{yk}/\gamma_s$ [MPa] 3.2.7(2)

characteristic yield strength of punching shear reinforcement, $f_{yk} = 500$ MPa

partial safety factor for reinforcing steel, $\gamma_s = 1.15$ Table 2.1N (NA 2.4.2.4(1))

Also, the minimum area of a single shear stud can be determined from:

$$A_{sw,min}(1.5\sin\alpha + \cos\alpha)/s_r s_t \geq 0.08\sqrt{f_{ck}}/f_{yk} \quad \text{eq. (9.11)}$$

where α = the angle between the shear reinforcement and the main steel.

For Shearfix, $\alpha = 90^\circ$ therefore $\sin\alpha = 1$, $\cos\alpha = 0$.

Therefore equation (9.11) can be rearranged and simplified:

$$A_{sw,min} \geq \frac{0.08s_r s_t \sqrt{f_{ck}}}{1.5f_{yk}}$$

where s_t = maximum tangential spacing of outermost studs [mm]

Typically, the number of shear studs per perimeter, or number of shear rails installed, is driven by the minimum spacing rules as described in Section 15. The area of punching shear reinforcement required per perimeter then dictates the size of each shear stud.

14 National Annex parameter values

The primary focus of our design approach is the Eurocode and its UK National Annex. However, to accommodate designs to other European National Annexes, the software allows the user to manually alter parameter values which are specified in the UK National Annex.

The values in grey font below can be altered. The value stated is the value in the UK National Annex and is set as default in the software.

National Annex parameters	Clauses	Purpose of parameter
$C_{Rd,c} = 0.18/\gamma_c$	6.4.4(1)	To calculate the design punching shear resistance of slabs without shear reinforcement, $v_{Rd,c}$
$v_{min} = 0.035k^{3/2}f_{ck}^{1/2}$		
$k_1 = 0.1$		
$v_{Rd,max} = 0.5v_{fcd}$	6.4.5(3)	The maximum limiting punching shear resistance at the column face
$k_{max}v_{Rd,c} = 2v_{Rd,c}$	6.4.5(1)	The maximum limiting punching shear resistance of the slab with shear reinforcement
Factor of distance, $k = 1.5$	6.4.5(4)	The outermost perimeter of shear reinforcement should be placed at a distance not greater than kd within u_{out} or $u_{out,ef}$.
<input checked="" type="checkbox"/> shear rail min'm length to $1.5d$ from column face		This clause sits in the UK National Annex and effectively prescribes a minimum of 3 studs per rail.

15 Layout of punching shear reinforcement

We have developed a procedure to determine the layout of Shearfix. This procedure is designed to accommodate the following detailing rules:

- Punching shear reinforcement should be detailed in accordance with BS EN 1992-1-1:2004 and its associated National Annex.
- The first stud is to be placed between $0.3d$ and $0.5d$ from the column face. (BS EN 1992-1-1:2004, Figure 9.10 a) and 9.4.3 (4).) (The default value is $0.5d$.)
- Radial spacing of studs should not exceed $0.75d$. (BS EN 1992-1-1:2004, 9.4.3 (1).) **Prior to Shearfix 6.3, the software fixed the radial spacing at $0.75d$. In revision 6.3, two radial spacing values are considered: $0.6d$ and $0.75d$.**
- The maximum tangential spacing of studs inside the basic control perimeter is $1.5d$. (BS EN 1992-1-1:2004, 9.4.3 (1).)
- The maximum tangential spacing of studs outside the basic control perimeter is $2d$. (BS EN 1992-1-1:2004, 9.4.3 (1).)
- **[text deleted]**
- The minimum clear tangential spacing between shear studs **on parallel rails is 50mm . For the first perimeter of shear studs, the minimum clear tangential spacing between shear studs is 0mm .**
- The outermost perimeter of studs should be at a distance no greater than $1.5d$ within u_{out} . (NA to BS EN 1992-1-1:2004, 6.4.5 (4).)
- The shape of the outer control perimeter u_{out} is dependent on the arrangement of shear reinforcement, the effective column dimensions and the ineffective regions due to slab openings. (See later in this section for more details.)

- There must be a minimum of two perimeters of punching shear reinforcement (according to the Eurocode). (BS EN 1992-1-1:2004, 9.4.3 (1).) See the next point.
- If the outer control perimeter u_{out} is situated within a distance of $3d$ from the column face, the shear studs should be placed between $0.3d$ and $1.5d$ from the column face. (NA to BS EN 1992-1-1:2004, 6.4.5 (4).) This is a UK National Annex criterion which effectively sets a minimum of three perimeters of punching shear reinforcement, overriding the Eurocode minimum of two perimeters.
- For rectangular columns, two radial layouts and a cruciform layout are available.
- Radial layouts are permitted with any column shape. Cruciform layouts are only permitted with rectangular columns.
- Prior to Shearfix 6.3, circular and oval columns could have 30° and 45° radial layouts. In Shearfix 6.3, these have been replaced with a new “auto” layout. This new approach starts with six main rails evenly spread around the circular perimeter (at 60°), it then incrementally adds an additional main rail (adjusting the spacing accordingly), generating a potential solution for each number of main rails considered.
- With radial layouts additional secondary reinforcement may be required to achieve the minimum tangential spacing between studs.
- With cruciform layouts secondary reinforcement is required at column corners.
- For Shearfix 6.3, a significant modification to cruciform layouts has been introduced. Now, adding an additional perimeter of studs always increases the outer perimeter length by ensuring the “corner” region of the cruciform layout is “filled” with studs.

The general procedures for radial and cruciform layouts are presented below.

15.1 Radial layout general procedure

Figure 14 illustrates the setting out points for radial layouts. For rectangular columns, the four setting out points are at the column corners. For circular columns, the setting out point is at the column centre. For oval columns, the two setting out points are at the radial centres of the circular column ends.

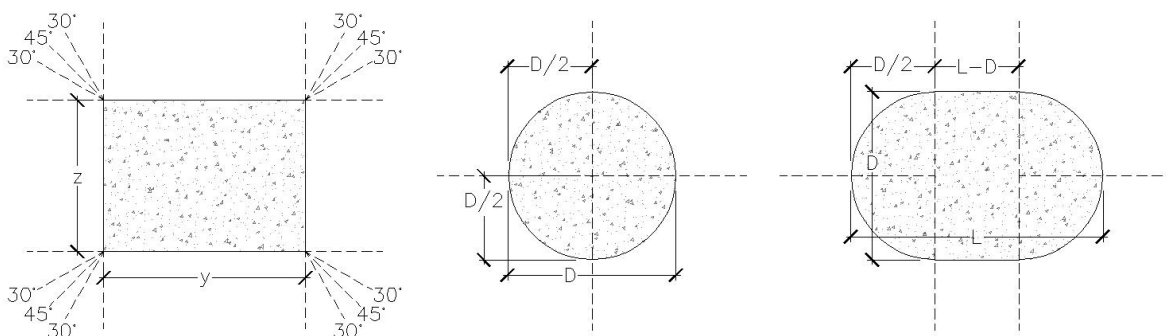

Figure 14 Radial layout setting out points

Secondary rails are placed between radial main rails where the tangential distance between studs exceeds the maximum limit. Inside the basic control perimeter, this limit is $1.5d$. Outside the basic control perimeter, this limit is $2d$.

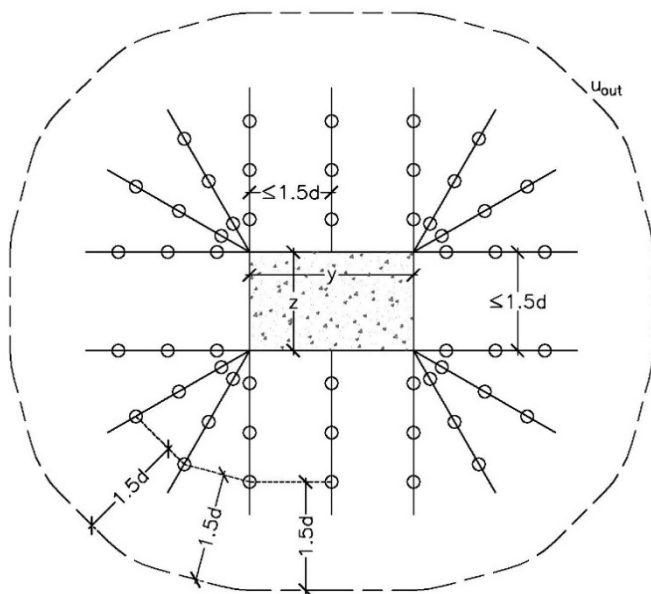

Figure 15 Radial layout of rails for internal rectangular column with associated outer control perimeter

15.2 Cruciform layout general procedure

Cruciform layouts are only permitted for rectangular columns. Figure 16 illustrates the setting out points for cruciform layouts which are at each column corner. [text deleted]

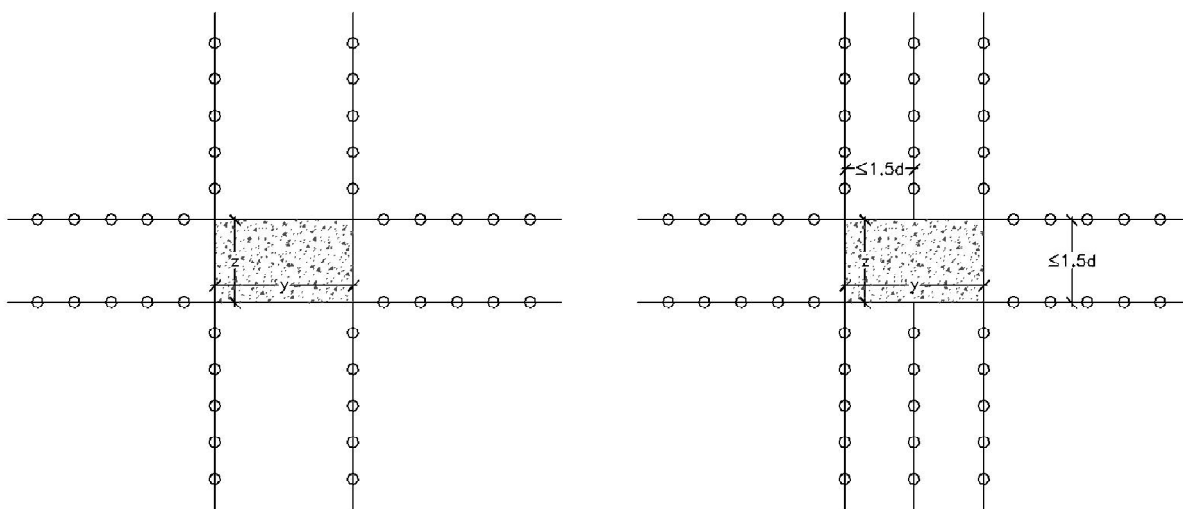

Figure 16 (i) and (ii) Cruciform layout procedure

Further main rails are placed along the column faces as necessary to suit a maximum spacing of $1.5d$. At the corners, the software “fills” the region with secondary rails to ensure minimum spacing rules are satisfied.

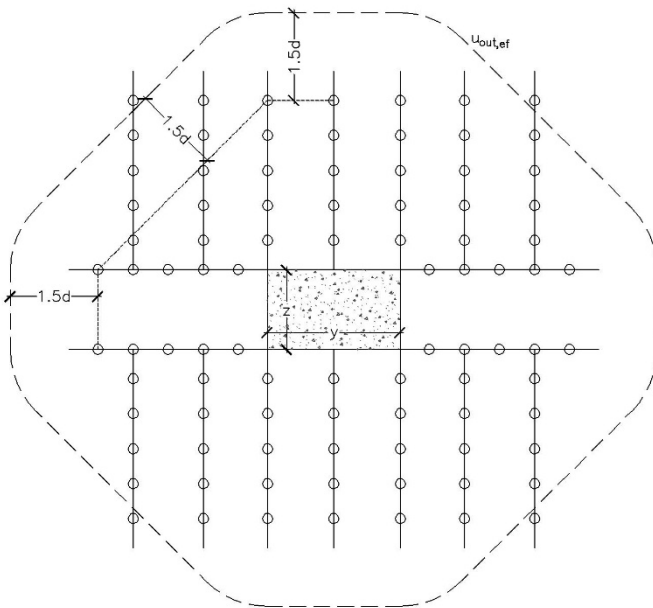

Figure 17 Cruciform rail layout and associated effective outer perimeter

15.3 Rails near slab openings and distribution rails

Any rails which pass through an opening in the slab are deleted. Any rail with at least one shear stud in an ineffective area becomes a distribution rail. An area of slab becomes ineffective due to: (a) an opening; or, (b) its distance from the corner of a large or elongated column (according to the design approach selected: Best Practice or EC2). Any rails which have all studs in an ineffective opening zone are deleted.

An example rail layout is illustrated in Figure 18. All rails illustrated are main rails unless indicated otherwise. In this example, there are fifteen main rails, six distribution rails and no secondary rails. This is an example of a “large” column adhering to the “Best Practice” design approach. It also illustrates a reduction in the basic and outer control perimeters due to the slab opening.

If the designer selects the Best Practice approach, they can choose to include or exclude distribution rails. If distribution rails are excluded, it is recommended that the designer independently checks the shear capacity in the ineffective zone and designs shear reinforcement accordingly. Also, the designer may deduct the beam shear (one-way shear) resisted by the ineffective zones from the design punching shear resisted by the effective zones. (ie. The design shear load entered in the software may be reduced.)

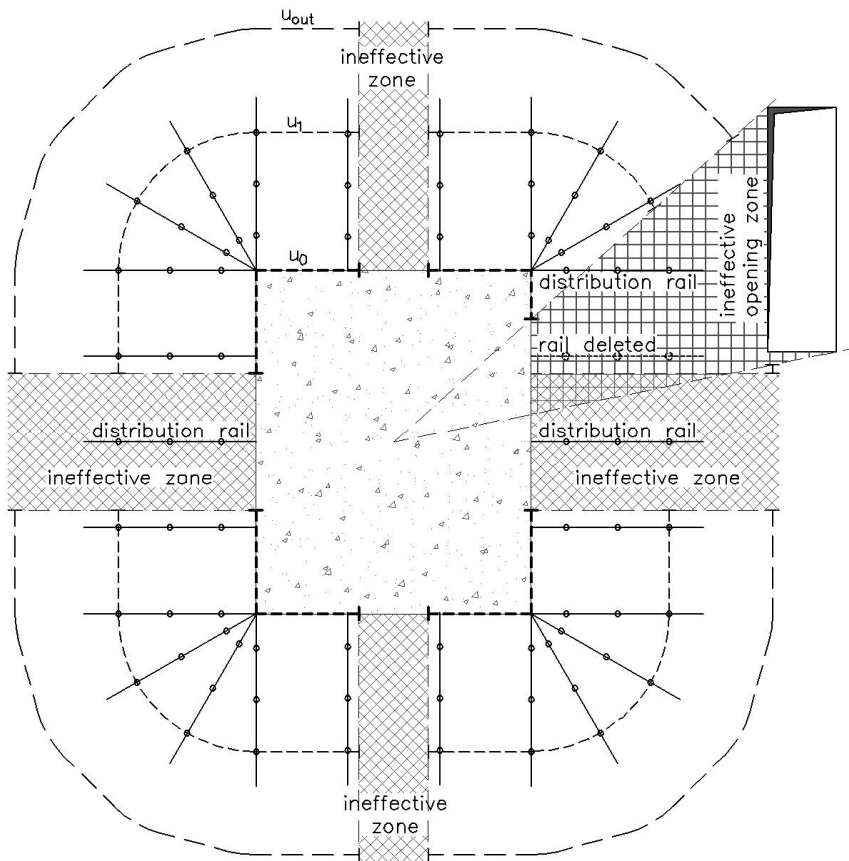

Figure 18 Example rail layout with deleted rails and ineffective main rails

16 Design Examples

Example	Location	Shape	Layout	Notes
1	Interior	Rectangular	Cruciform	Change in slab depth
2	Edge	Oval	Radial	Edge → internal + virtual opening
3	Corner	Rectangular	Optimum	“Elongated” column Rectangular opening Two layers of reinforcement
4	Re-entrant corner	Circular	Radial	Circular opening Two layers of reinforcement

16.1 Internal rectangular column

16.1.1 Inputs

Internal rectangular column		
Dimensions,	y =	600 mm
	z =	400 mm
Slab depth,	h ₁ =	290 mm
	h ₂ =	250 mm
Change in slab depth: bottom surface	@ y =	0 mm
Concrete grade, C30/37	f _{ck} =	30 N/mm ²
Top cover,	c _{nom,t} =	30 mm
Bottom cover,	c _{nom,b} =	30 mm
Pre-compression,	σ _{cp} =	0 N/mm ²
Reinforcement, Layer 1,	y-y	H16 @200 mm c/c
	z-z	H16 @200 mm c/c
Loading	Design shear	V _{Ed} = 600 kN
	β	To be calculated
	Design moments	M _{Ed,y} = 20 kNm
		M _{Ed,z} = 40 kNm
Distance to first stud	S _{r0} =	0.5 d
Shearfix	Layout	Cruciform
	Stud ø	Automatic optimal
	Rail placing	Bottom-up
	Large and elongated columns	Best Practice
	Include distribution rails	Yes

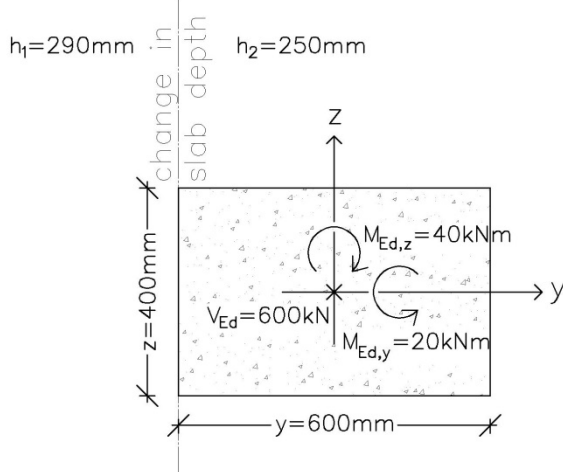

16.1.2 Design

Design parameters

Effective depth,

$$h = \min(h_1, h_2) = h_2$$

$$d_{y1} = h - c_{nom,t} - \phi_{y1}/2 = 212\text{mm}$$

$$d_{z1} = h - c_{nom,t} - \phi_{y1} - \phi_{z1}/2 = 196\text{mm}$$

$$d = (d_{y1} + d_{z1})/2 = 204\text{mm}$$

Control perimeters,

$$a = \max(y, z) = 600\text{mm} \quad b = \min(y, z) = 400\text{mm}$$

$$a_1 = \min(a, 4b, 3d) = \min(600, 1600, 612) = 600\text{mm}$$

$$b_1 = \min(b, 3d) = \min(400, 612) = 400\text{mm}$$

$$\text{NA 3.1.6 (1)} \quad \alpha_{cc} = 1.0 \quad \text{“all other phenomena”}$$

$$f_{cd} = 20.0 \text{ MPa} \quad v_{Rd,max} = 5.28 \text{ MPa}$$

CHECK: $v_{Ed,0} \leq v_{Rd,max}$ → OK to proceed with design

Shear at basic control perimeter without reinforcement

Applied design shear at basic control perimeter, (6.38) $v_{Ed,1} = \frac{\beta V_{Ed}}{u_1 d}$ $v_{Ed,1} = 0.71 \text{ MPa}$

Design shear capacity without reinforcement,

$$(6.47) \quad v_{Rd,c} = \left[C_{Rd,c} k (100 \rho_l f_{ck})^{1/3} + k_1 \sigma_{cp} \right] \geq (v_{min} + k_1 \sigma_{cp})$$

where, $C_{Rd,c} = 0.18 / \gamma_c = 0.12$

$$k = 1 + \sqrt{200/d} \leq 2.0 \quad \rightarrow k = 1.99$$

$$\rho_l = \sqrt{\rho_{lx} \rho_{ly}} \leq 0.02 \quad \rightarrow \rho_l = 0.00493$$

$$\text{(NA6.4.4)} \quad k_1 = 0.1$$

$$\text{(NA6.4.4)} \quad v_{min} = 0.035 k^{3/2} f_{ck}^{1/2} = 0.538$$

$$v_{Rd,c} = 0.586 \geq 0.538 \quad v_{Rd,c} = 0.59 \text{ MPa}$$

Limiting value of punching shear capacity, $v_{Rd,c,max} = 2 \times v_{Rd,c}$ $v_{Rd,c,max} = 1.17 \text{ MPa}$

CHECK: $v_{Ed,1} > v_{Rd,c}$ → punching shear reinforcement required

$v_{Ed,1} \leq v_{Rd,c,max}$ → OK to proceed with design

Extent of punching shear reinforcement required

Control perimeter at which reinforcement is no longer required,

$$u_{out,req} = \frac{\beta V_{Ed}}{v_{Rd,c} d} \quad u_{out,req} = 5554 \text{ mm}$$

Cruciform layout

[text deleted]

Distance to first stud, $s_{r0} = 0.5d = 102 \text{ mm}$

rounded down to nearest 1mm → $s_{r0} = 102 \text{ mm}$

Radial spacing of studs, $s_r = 0.75d = 153 \text{ mm}$

rounded down to nearest 1mm → $s_r = 153 \text{ mm}$

[text deleted]

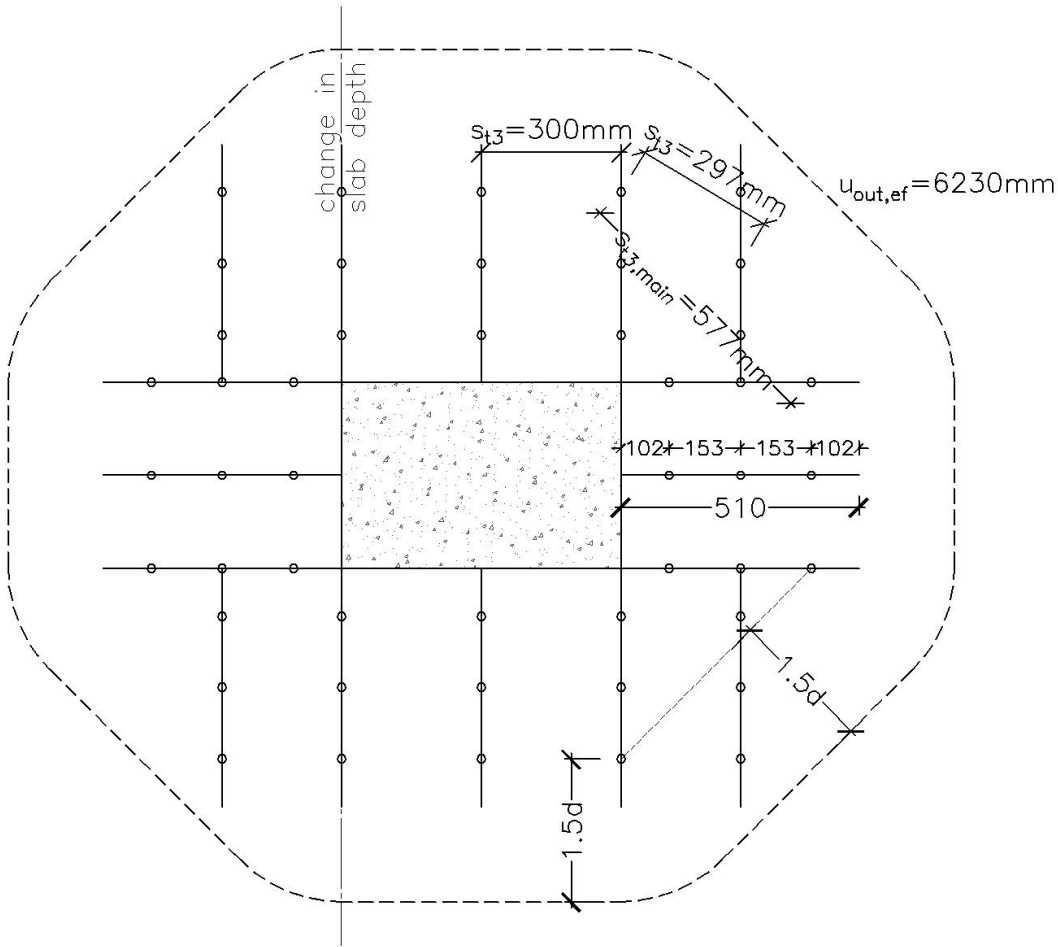

Length of main rails

The optimal solution has “radial” stud spacing of $0.75d = 153\text{mm}$ and three studs per rail. Therefore the main rails are 510mm in length.

Secondary rails

Maximum permitted tangential spacing of studs, $2d = 408\text{ mm}$

Actual tangential spacing of outermost studs, $577 > 408$

Therefore, another 4 secondary rails required with three shear studs per rail.

New tangential spacing of outermost studs, $297 < 408$. Therefore no further secondary rails required.

Shear stud size

$$A_{sw} = \frac{(v_{Ed,1} - 0.75v_{Rd,c})s_r u_1}{1.5f_{ywd,ef}} \quad \text{and} \quad A_{sw,min} \geq \frac{0.08s_r s_t \sqrt{f_{ck}}}{1.5f_{yk}}$$

where

$$f_{yk} = 500 \text{ MPa}$$

$$f_{ywd,ef} = 250 + 0.25d \leq f_{ywd}$$

$$f_{ywd} = \frac{f_{yk}}{1.15} = 435 \text{ MPa}$$

$$f_{ywd,ef} = 301 \leq 435$$

$$s_r = 153 \text{ mm}$$

$$s_t = 300 \text{ mm}$$

$$A_{sw} = 424 \text{ mm}^2 \text{ per perimeter}$$

$$A_{sw,min} = 27 \text{ mm}^2 \text{ per stud}$$

Number of main rail shear studs per perimeter = 12

$$A_{stud} = A_{sw}/n_{mr} \geq A_{sw,min}$$

$$A_{stud} = 35.3 \geq 27$$

$$A_{stud,required} = 35.3$$

10mm \emptyset stud: $A_{stud,provided} = 78.5 \text{ mm}^2 > A_{stud,required}$

Therefore, optimal stud diameter for a cruciform layout is 10mm \emptyset

Stud height

$$h_{stud,h1} = h_1 - c_{nom,t} - c_{nom,b}$$

$$h_{stud,h1} = 290 - 30 - 30 = 230 \text{ mm}$$

$$h_{stud,h2} = h_2 - c_{nom,t} - c_{nom,b}$$

$$h_{stud,h2} = 250 - 30 - 30 = 190 \text{ mm}$$

Therefore, studs are either 230mm high or 190mm high.

Shear capacity with punching shear reinforcement

Shear capacity with reinforcement,

$$(6.52) \quad v_{Rd,cs} = 0.75v_{Rd,c} + 1.5\left(\frac{d}{s_r}\right)A_{sw}f_{ywd,ef}\left(\frac{1}{u_1d}\right)\sin\alpha$$

where, $A_{sw} = 12 \times 78.5 = 942 \text{ mm}^2$

$$\alpha = 90^\circ \quad \rightarrow \sin\alpha = 1$$

$$\rightarrow v_{Rd,cs} = \underline{1.05 \text{ MPa}}$$

16.1.3 Design solution

Cruciform layout

- 9 no. main rails (3 x 10mm \varnothing studs @ 153mm c/c, 510mm long, 190mm high)
- 3 no. main rails (3 x 10mm \varnothing studs @ 153mm c/c, 510mm long, 230mm high)
- 2 no. secondary rails (3 x 10mm \varnothing studs @ 153mm c/c, 357mm long, 190mm high)
- 2 no. secondary rails (3 x 10mm \varnothing studs @ 153mm c/c, 357mm long, 230mm high)

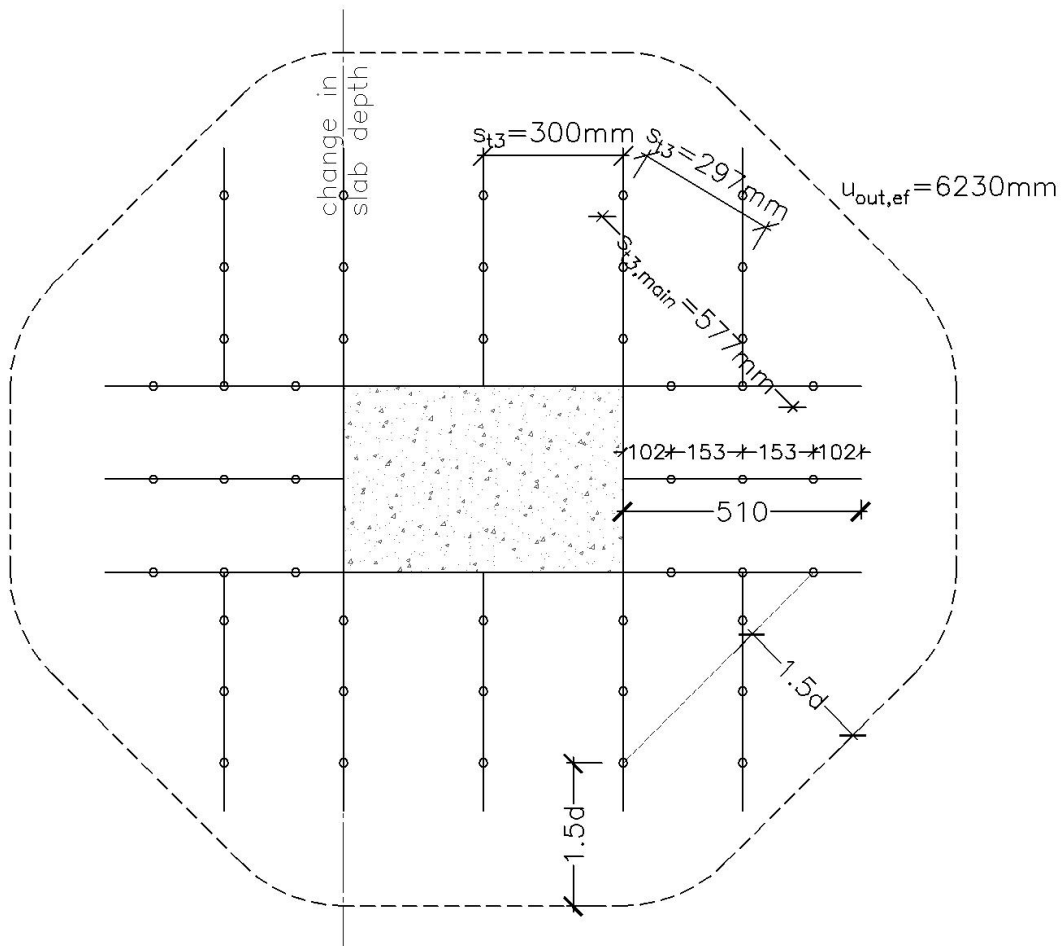

16.2 Edge oval column

16.2.1 Inputs

Edge oval column		
Dimensions,	y =	600 mm
	z =	400 mm
	Edge @ right	a _{e,y} = 750 mm
Slab depth,	h =	230 mm
Concrete grade,	C28/35	f _{ck} = 28 N/mm ²
Top cover,	c _{nom,t} =	25 mm
Bottom cover,	c _{nom,b} =	25 mm
Pre-compression,	σ _{cp} =	0 N/mm ²
Reinforcement,	Layer 1,	y-y H16 @200 mm c/c
		z-z H16 @200 mm c/c
Loading	Design shear	V _{Ed} = 300 kN
	β	To be calculated
	Design moments	M _{Ed,y} = 1 kNm
		M _{Ed,z} = -15 kNm
Distance to first stud		S _{r0} = 0.5 d
Shearfix	Layout	auto
	Stud ø	Automatic optimal
	Rail placing	Bottom-up
	Large and elongated columns	Best Practice
	Include distribution rails	Yes

Towards interior

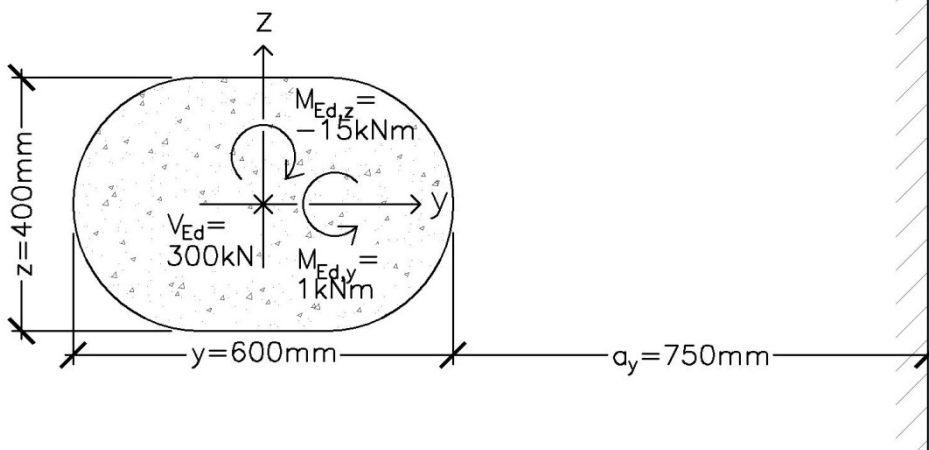

16.2.2 Design

Design parameters

$$\begin{aligned}
 \text{Effective depth, } d_{y1} &= h - c_{nom,t} - \phi_{y1}/2 &&= 197\text{mm} \\
 d_{z1} &= h - c_{nom,t} - \phi_{y1} - \phi_{z1}/2 &&= 181\text{mm} \\
 d &= (d_{y1} + d_{z1})/2 &&= 189\text{mm}
 \end{aligned}$$

$$\begin{aligned}
 \text{Control perimeters, } L &= \max(y, z) = 600\text{mm} && D = \min(y, z) = 400\text{mm} \\
 L_1 &= \min(L - D, 3D, 3d) = \min(200, 1200, 567) = 200\text{mm} \\
 L_{1u0} &= \min(L - D, 3D, 1.5d) = \min(200, 1200, 283.5) = 200\text{mm}
 \end{aligned}$$

$$g_L = L + a_L - \frac{D}{2} = 1150\text{mm} \quad \text{where } a_L = a_{e,y} = 750\text{mm}$$

$$u_{0,edge} = 2L_{1u0} + \frac{\pi}{2}D = 1028\text{mm}$$

$$u_{1,edge} = 2L_1 + \frac{\pi}{2}(D + 4d) + 2(g_L - L + D) = 4116\text{mm}$$

$$u_{0,int} = 2L_1 + \pi D = 1657\text{mm}$$

$$u_{1,int} = 2L_1 + \pi(D + 4d) = 4032\text{mm}$$

$u_{1,int} < u_{1,edge} \rightarrow$ design as internal column
 $a_y < 6d \rightarrow$ treat edge as virtual opening:

opening: $l_y = \frac{y}{2} + a_{e,y} + \frac{y'}{2} = 1100\text{mm}, l_z = 0\text{mm},$
 $y' = 100\text{mm}, z' = z + 12d = 2668\text{mm}$

... with opening reduction,

$$u_0 = 1134\text{mm}$$

$$u_1 = 2829\text{mm}$$

Reinforcement ratio,

$$\rho_{ly} = \frac{A_{sy1}}{A_{cy1}} = 0.00510 \quad \rho_{lz} = \frac{A_{sz1}}{A_{cz1}} = 0.00555$$

$$\rho_l = \sqrt{\rho_{ly} \times \rho_{lz}} = 0.00532 \quad (\equiv 0.532\%)$$

Load increase factor,

Internal column with biaxial moments: greatest value of

$$\beta = 1 + k \frac{M'_{Ed} u_1}{V_{Ed} W_1} \quad \text{and} \quad \beta = 1 + 1.8 \sqrt{\left(\frac{e_y}{b_z}\right)^2 + \left(\frac{e_z}{b_y}\right)^2}$$

internal column: $M'_{Ed,y} = M_{Ed,y}$ and $M'_{Ed,z} = M_{Ed,z}$
 $u_1 = 4032 \text{ mm}$ (without opening reduction)

$$\beta = 1 + k \frac{M'_{Ed} u_1}{V_{Ed} W_1} \rightarrow \beta = 1.076$$

$$\beta = 1 + 1.8 \sqrt{\left(\frac{e_y}{b_z}\right)^2 + \left(\frac{e_z}{b_y}\right)^2} \rightarrow \beta = 1.078$$

$1.078 > 1.076 \quad \therefore \beta = 1.078$

Results so far

Effective depth	d =	189	mm
Control perimeters	u ₀ =	1134	mm
	u ₁ =	2829	mm
Reinforcement ratios	ρ _l =	0.00532	
Load increase factor	β =	1.078	

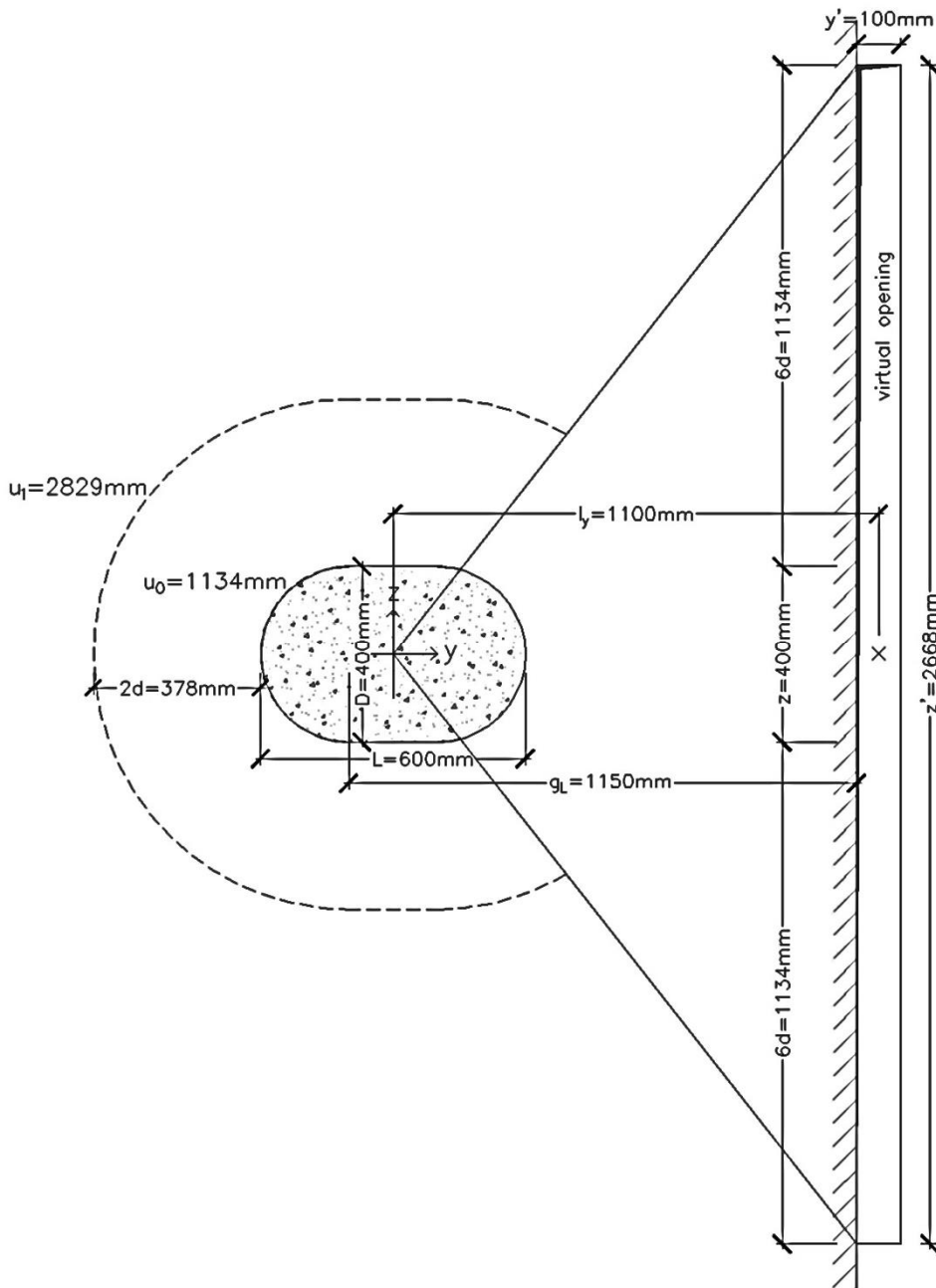

Shear at column face

Applied design shear at column face, (6.53) $v_{Ed,0} = \frac{\beta V_{Ed}}{u_0 d}$

where, $u_0 = 1134 \text{ mm}$ (with opening reduction)

$v_{Ed,0} = 1.51 \text{ MPa}$

Design shear capacity without reinforcement, $v_{Rd,max} = 0.5 v f_{cd}$

where, (6.6N) $v = 0.6 \left[1 - \frac{f_{ck}}{250} \right] = 0.533$

(3.15) $f_{cd} = \frac{\alpha_{cc} f_{ck}}{\gamma_c}$

Table 2.1N $\gamma_c = 1.5$ "persistent and transient"

(3.1.6) $\alpha_{cc} = 1.0$ "all other phenomena"

$f_{cd} = 18.67 \text{ MPa}$

$v_{Rd,max} = 4.97 \text{ MPa}$

CHECK: $v_{Ed,0} \leq v_{Rd,max} \rightarrow \text{OK to proceed with design}$

Shear at basic control perimeter without reinforcement

Applied design shear at basic control perimeter, (6.38) $v_{Ed,1} = \frac{\beta V_{Ed}}{u_1 d}$

where, $u_1 = 2829 \text{ mm}$ (with opening reduction)

$$v_{Ed,1} = 0.60 \text{ MPa}$$

Design shear capacity without reinforcement,

$$(6.47) \quad v_{Rd,c} = \left[C_{Rd,c} k (100 \rho_l f_{ck})^{1/3} + k_1 \sigma_{cp} \right] \geq (v_{min} + k_1 \sigma_{cp})$$

where, $C_{Rd,c} = 0.18 / \gamma_c = 0.12$

$$k = 1 + \sqrt{200/d} \leq 2.0 \quad \rightarrow k = 2.0$$

$$\rho_l = \sqrt{\rho_{lx} \rho_{ly}} \leq 0.02 \quad \rightarrow \rho_l = 0.00532$$

$$(NA6.4.4) \quad k_1 = 0.1$$

$$(NA6.4.4) \quad v_{min} = 0.035 k^{3/2} f_{ck}^{1/2} = 0.524$$

$$v_{Rd,c} = 0.591 \geq 0.524$$

$$v_{Rd,c} = 0.59 \text{ MPa}$$

Limiting value of punching shear capacity,

$$v_{Rd,c,max} = 2 \times v_{Rd,c} \quad v_{Rd,c,max} = 1.18 \text{ MPa}$$

CHECK:

$$v_{Ed,1} > v_{Rd,c} \quad \rightarrow \text{punching shear reinforcement required}$$

$$v_{Ed,1} \leq v_{Rd,c,max} \quad \rightarrow \text{OK to proceed with design}$$

Extent of punching shear reinforcement required

Control perimeter at which reinforcement is no longer required,

$$u_{out,req} = \frac{\beta V_{Ed}}{v_{Rd,c} d}$$

$$u_{out,req} = 2897 \text{ mm}$$

Auto layout

The software automatically generates numerous layout options and selects the optimal solution:

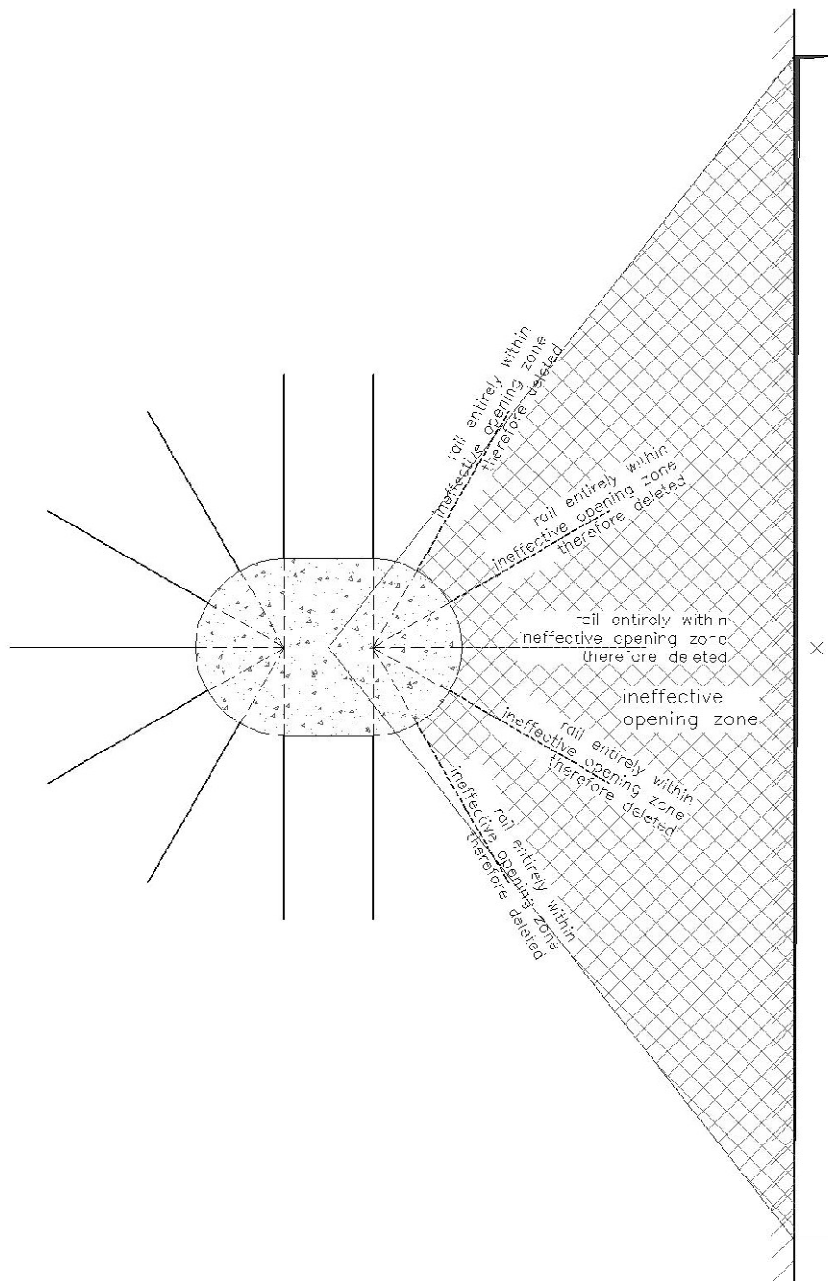

Main rails for optimal solution

Distance to first stud, $s_{r0} = 0.5d = 94.5mm$
 rounded down to nearest 1mm $\rightarrow s_{r0} = 94mm$

Radial spacing of studs, $s_r = 0.6d = 113.4mm$
 rounded down to nearest 1mm $\rightarrow s_r = 113mm$

The optimal solution places rails at 60° and secondary rails at 30°. (This is effectively the same as placing main rails at 30°.)

Secondary rails

Maximum tangential spacing inside basic control perimeter, $1.5d = 283.5 mm$

Stud number	Maximum tangential spacing	Tangential spacing	Secondary rail required?
3	520 mm	269mm	> 1.5d secondary rail required
2	407 mm	211mm	> 1.5d secondary rail required
1	294 mm	152mm	> 1.5d secondary rail required

Therefore, **three** secondary rails required with **three** shear studs per rail.

Shear stud size

$$A_{sw} = (v_{Ed,1} - 0.75v_{Rd,c})s_r u_1 / 1.5f_{ywd,ef} \quad \text{and} \quad A_{sw,min} \geq 0.08s_r s_t \sqrt{f_{ck}} / 1.5f_{yk}$$

where

$$f_{yk} = 500 \text{ MPa}$$

$$f_{ywd,ef} = 250 + 0.25d \leq f_{ywd}$$

$$f_{ywd} = \frac{f_{yk}}{1.15} = 435 \text{ MPa}$$

$$f_{ywd,ef} = 297 \leq 435$$

$$s_r = 113 \text{ mm}$$

$$s_t = 269 \text{ mm}$$

$$A_{sw} = 113 \text{ mm}^2 \text{ per perimeter}$$

$$A_{sw,min} = 17.2 \text{ mm}^2 \text{ per stud}$$

Minimum number of effective main rail shear studs per perimeter = **6**

$$A_{stud} = A_{sw} / n_{mr} \geq A_{sw,min}$$

$$A_{stud} = 18.8 > 17.2$$

$$A_{stud,required} = 18.8$$

10mm \varnothing stud: $A_{stud,provided} = 78.5 \text{ mm}^2 \geq A_{stud,required}$

Therefore, optimal stud diameter for **this** layout is 10mm \varnothing

Stud height

$$h_{stud} = h - c_{nom,t} - c_{nom,b}$$

$$h_{stud} = 230 - 25 - 25 = 180 \text{ mm}$$

Therefore, studs are 180mm high.

Shear capacity with punching shear reinforcement

Shear capacity with reinforcement,

$$(6.52) \quad v_{Rd,cs} = 0.75v_{Rd,c} + 1.5\left(\frac{d}{s_r}\right)A_{sw}f_{ywd,ef}\left(\frac{1}{u_1d}\right)\sin\alpha$$

where, $A_{sw} = 6 \times 78.5 = 471 \text{ mm}^2$

$$\alpha = 90^\circ \quad \rightarrow \sin\alpha = 1$$

$$\rightarrow v_{Rd,cs} = 1.10 \text{ MPa}$$

16.2.3 Design solution

Auto layout

6 no. main rails (3 x 10mm \varnothing studs @ **113**mm c/c, **414**mm long, 180mm high)

3 no. secondary rails (**3** x 10mm \varnothing studs @ **113**mm c/c, **414**mm long, 180mm high)

16.3 Corner rectangular column

16.3.1 Inputs

Corner rectangular column

Dimensions,		y =	300	mm
		z =	900	mm
	Edge @ right	a _{e,y} =	400	mm
	Edge @ top	a _{e,z} =	250	mm
Slab depth,		h =	250	mm
Concrete grade,	C35/45	f _{ck} =	35	N/mm ²
Top cover,		c _{nom,t} =	25	mm
Bottom cover,		c _{nom,b} =	25	mm
Pre-compression,		σ _{cp} =	0	N/mm ²
Reinforcement,	Layer 1,	y-y	H12 @150 mm c/c	
		z-z	H12 @150 mm c/c	
	Layer 2,	y-y	H16 @150 mm c/c	
		z-z	H16 @150 mm c/c	
Loading	Design shear	V _{Ed} =	210	kN
	β	To be calculated		
	Design moments	M _{Ed,y} =	12	kNm
		M _{Ed,z} =	-10	kNm
Opening	Rectangular	l _y =	-800	mm
		l _z =	450	mm
		y' =	100	mm
		z' =	200	mm
Distance to first stud		S _{r0} =	0.5	d
Shearfix	Layout	Automatic optimal		
	Stud ø	Automatic optimal		
	Rail placing	Bottom-up		
	Large and elongated columns	Best Practice		
	Include distribution rails	Yes		

Towards interior
Towards interior

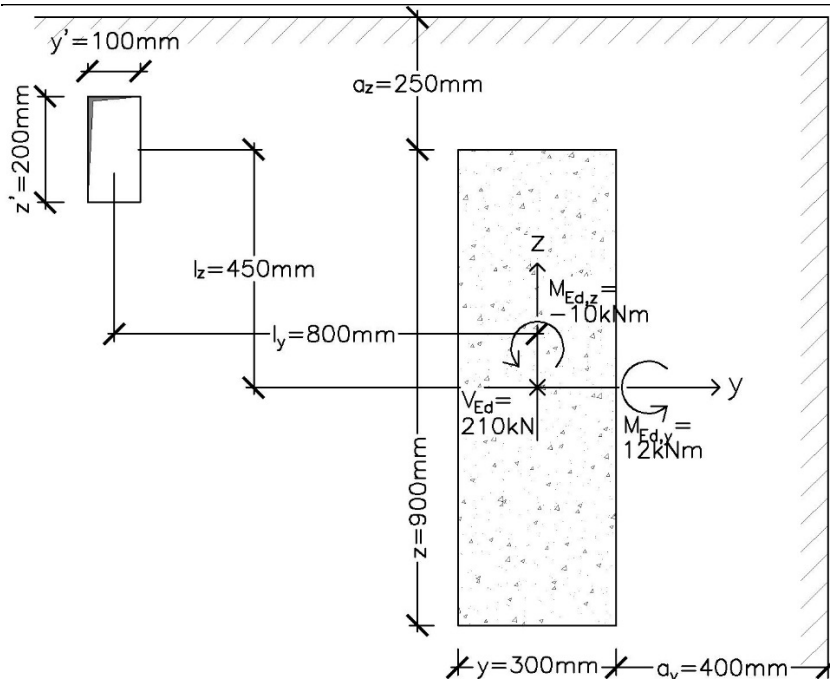

16.3.2 Design

Design parameters

Effective depth,

$$d_{y1} = h - c_{nom,t} - \phi_{y1}/2 = 219mm$$

$$d_{z1} = h - c_{nom,t} - \phi_{y1} - \phi_{z1}/2 = 207mm$$

$$d_{y2} = h - c_{nom,t} - \phi_{y1} - \phi_{z1} - \phi_{y2}/2 = 193mm$$

$$d_{z2} = h - c_{nom,t} - \phi_{y1} - \phi_{z1} - \phi_{y2} - \phi_{z2}/2 = 177mm$$

$$d = (d_{y1} + d_{z1} + d_{y2} + d_{z2})/4 = 199mm$$

Opening,

$$l_1 = 100mm, \quad l_2 = 200mm, \quad \sqrt{l_1 \times l_2} = 141.42mm$$

where l_3 found using CAD: $l_3 = 222.04mm \geq \sqrt{l_1 l_2} \quad \therefore l_3 = 222mm$

Control perimeters,

$$a = \max(y, z) = 900mm \quad b = \min(y, z) = 300mm$$

$$g_a = a_{e,z} = 250mm \quad g_b = a_{e,y} = 400mm$$

$$a_1 = \min(a, 4b, 3d) = \min(900, 1200, 597) = 597mm$$

$$a_{1u0} = \min(a, 4b, 1.5d) = \min(900, 1200, 298.5) = 298.5mm$$

$$b_1 = \min(b, 3d) = \min(300, 597) = 300mm$$

$$b_{1u0} = \min(b, 1.5d) = \min(300, 298.5) = 298.5mm$$

without opening,

$$u_0 = a_{1u0} + b_{1u0} = 597mm$$

$$u_1 = a_1 + b_1 + g_a + g_b + \pi d = 2172mm$$

with opening,

$$u_0 = 597mm$$

$$u_1 = 1996mm$$

Reinforcement ratio,

$$\rho_{ly} = \frac{A_{sy1}}{A_{cy1}} + \frac{A_{sy2}}{A_{cy2}} = 0.0104 \quad \rho_{lz} = \frac{A_{sz1}}{A_{cz1}} + \frac{A_{sz2}}{A_{cz2}} = 0.0112$$

$$\rho_l = \sqrt{\rho_{ly} \times \rho_{lz}} = 0.01079 (\equiv 1.079\%)$$

Load increase factor,

Corner column: Is moment towards interior or exterior of slab?
centroid of control perimeter (ignoring opening reduction),
where a positive y_0 or z_0 value is in negative y- or z-direction.

$$y_0 = 265.3mm$$

$$z_0 = 409.6mm$$

where $u_1 = 2172mm$ (without opening reduction)
moment about centroid of basic control perimeter,

$$M'_{Ed,y} = M_{Ed,y} - z_0 V_{Ed} = -74.02kNm \leq 0 \quad \therefore \text{towards exterior}$$

$$M'_{Ed,z} = M_{Ed,z} - y_0 V_{Ed} = -45.71kNm \leq 0 \quad \therefore \text{towards exterior}$$

Therefore, load increase factor:

$$\beta = 1 + k \frac{M'_{Ed} u_1}{V_{Ed} W_1} \rightarrow \beta = 1.700$$

Results so far

Effective depth	d =	199	mm
Control perimeters	$u_0 =$	597	mm
	$u_1 =$	1996	mm

Reinforcement ratios	$\rho_l = 0.01079$
Load increase factor	$\beta = 1.700$

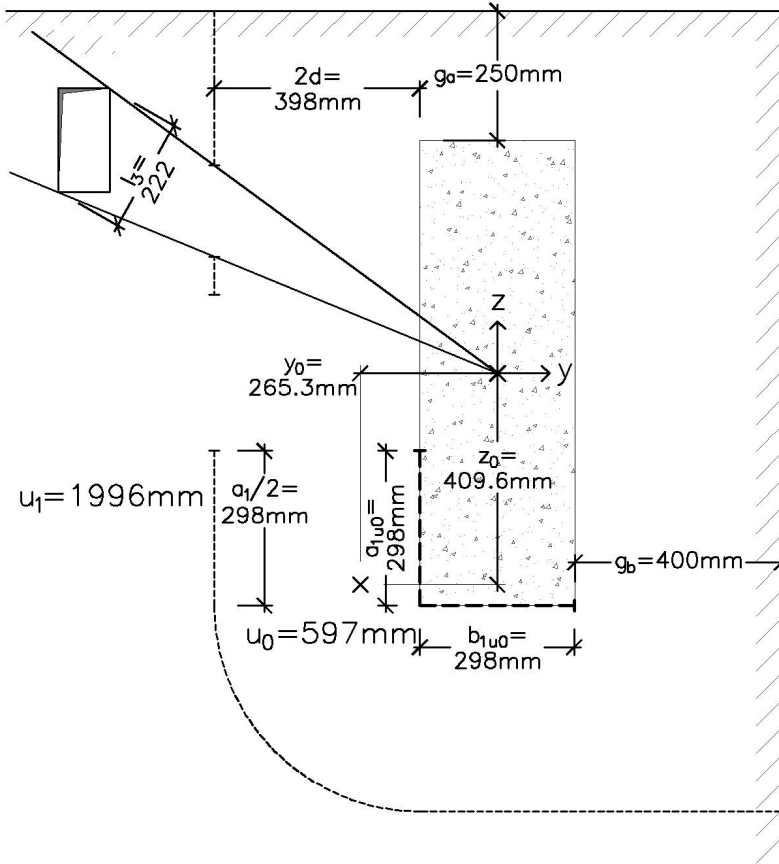

Shear at column face

Applied design shear at column face, (6.53) $v_{Ed,0} = \frac{\beta V_{Ed}}{u_0 d}$ $v_{Ed,0} = 3.00 \text{ MPa}$

Design shear capacity without reinforcement, $v_{Rd,max} = 0.5 v f_{cd}$

where, (6.6N) $v = 0.6 \left[1 - \frac{f_{ck}}{250} \right] = 0.516$

(3.15) $f_{cd} = \frac{\alpha_{cc} f_{ck}}{\gamma_c}$

Table 2.1N $\gamma_c = 1.5$ "persistent and transient"

(3.1.6) $\alpha_{cc} = 1.0$ "all other phenomena"

$f_{cd} = 23.33 \text{ MPa}$ $v_{Rd,max} = 6.02 \text{ MPa}$

CHECK: $v_{Ed,0} \leq v_{Rd,max}$ → OK to proceed with design

Shear at basic control perimeter without reinforcement

Applied design shear at basic control perimeter, (6.38) $v_{Ed,1} = \frac{\beta V_{Ed}}{u_1 d}$ $v_{Ed,1} = 0.90 \text{ MPa}$

Design shear capacity without reinforcement,

(6.47) $v_{Rd,c} = \left[C_{Rd,c} k (100 \rho_l f_{ck})^{1/3} + k_1 \sigma_{cp} \right] \geq (v_{min} + k_1 \sigma_{cp})$

where, $C_{Rd,c} = 0.18 / \gamma_c = 0.12$

$k = 1 + \sqrt{200/d} \leq 2.0$ → $k = 2.0$

$\rho_l = \sqrt{\rho_{lx} \rho_{ly}} \leq 0.02$ → $\rho_l = 0.01079$

$$(NA6.4.4) \quad k_1 = 0.1$$

$$(NA6.4.4) \quad v_{min} = 0.035k^{3/2}f_{ck}^{1/2} = 0.586$$

$$v_{RD,c} = 0.805 \geq 0.586$$

$$v_{RD,c} = 0.81 \text{ MPa}$$

Limiting value of punching shear capacity, $v_{RD,c,max} = 2 \times v_{RD,c} \quad v_{RD,c,max} = 1.61 \text{ MPa}$

CHECK: $v_{Ed,1} > v_{RD,c} \quad \rightarrow$ punching shear reinforcement required

$v_{Ed,1} \leq v_{RD,c,max} \quad \rightarrow$ OK to proceed with design

Extent of punching shear reinforcement required

Control perimeter at which reinforcement is no longer required,

$$u_{out,req} = \frac{\beta V_{Ed}}{v_{RD,c}d}$$

$$u_{out,req} = 2228 \text{ mm}$$

30° Radial layout

Main rails

[text deleted]

The optimal 30° radial layout established by the software contains 8 main rails with three studs per rail and a radial stud spacing of s_r of $0.75d = 149\text{mm}$. The length of each main rail is 496mm. With this arrangement, the length of the outer perimeter is $2360.5\text{mm} \geq 2228\text{mm}$.

Secondary rails

Maximum tangential spacing inside basic control perimeter, $1.5d = 298.5 \text{ mm}$

Stud number	Maximum tangential spacing	Secondary rail required?
3	206 mm	$\leq 1.5d$ secondary rail not required

Therefore, secondary rails not required.

Shear stud size

$$A_{sw} = \frac{(v_{Ed,1} - 0.75v_{RD,c})s_r u_1}{1.5f_{ywd,ef}} \quad \text{and} \quad A_{sw,min} \geq \frac{0.08s_r s_t \sqrt{f_{ck}}}{1.5f_{yk}}$$

where

$$f_{yk} = 500 \text{ MPa}$$

$$f_{ywd,ef} = 250 + 0.25d \leq f_{ywd}$$

$$f_{ywd} = \frac{f_{yk}}{1.15} = 435 \text{ MPa}$$

$$f_{ywd,ef} = 300 \leq 435$$

$$s_r = 149 \text{ mm}$$

$$s_t = 225 \text{ mm}$$

$$A_{sw} = 193.3 \text{ mm}^2 \text{ per perimeter}$$

$$A_{sw,min} = 21.2 \text{ mm}^2 \text{ per stud}$$

Minimum number of effective main rail shear studs per perimeter = 8

(not including distribution rails indicated in figure below)

$$A_{stud} = \frac{A_{sw}}{n_{mr}} \geq A_{sw,min}$$

$$A_{stud} = 24.2 \geq 21.2$$

$$A_{stud,required} = 24.2$$

10mm ϕ stud: $A_{stud,provided} = 78.5 \text{ mm}^2 > A_{stud,required}$

[text deleted]

Stud height $h_{stud} = h - c_{nom,t} - c_{nom,b}$
 $h_{stud} = 250 - 25 - 25 = 200 \text{ mm}$

Therefore, studs are 200mm high.

30° radial solution:

- 8 no. main rails (3 x 10mm ϕ studs @ 149mm c/c, 496mm long, 200mm high)
- 8 no. distribution rails (3 x 10mm ϕ studs @ 149mm c/c, 496mm long, 200mm high)
- 3 no. distribution rails (2 x 10mm ϕ studs @ 149mm c/c, 347mm long, 200mm high)

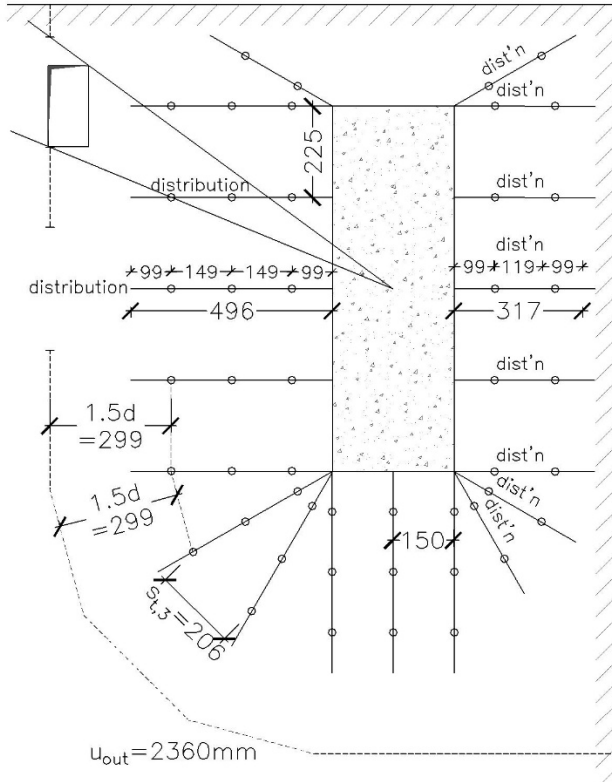

45° Radial layout

Main rails

[text deleted]

The optimal 45° radial layout established by the software contains 7 main rails, with three studs per rail and a radial stud spacing s_r of $0.6d = 119\text{mm}$. The length of each main rail is 436mm. With this arrangement, the length of the outer perimeter is 2279.1mm \geq 2228mm.

Secondary rails

Maximum tangential spacing inside basic control perimeter, $1.5d = 298.5 \text{ mm}$

Stud number	Maximum tangential spacing	Secondary rail required?
3	258 mm	$\leq 1.5d$ secondary rail not required

[text deleted]

Therefore, secondary rails not required.

Shear stud size

$$A_{sw} = \frac{(v_{Ed,1} - 0.75v_{RD,c})s_r u_1}{1.5f_{ywd,ef}} \quad \text{and} \quad A_{sw,min} \geq \frac{0.08s_r s_t \sqrt{f_{ck}}}{1.5f_{yk}}$$

where $f_{yk} = 500 \text{ MPa}$
 $f_{ywd,ef} = 300$
 $s_r = 119 \text{ mm}$
 $s_t = 258 \text{ mm}$

$$A_{sw} = 154.4 \text{ mm}^2 \text{ per perimeter}$$

$$A_{sw,min} = 19.4 \text{ mm}^2 \text{ per stud}$$

Minimum number of effective main rail shear studs per perimeter = 7

$$A_{stud} = A_{sw} / n_{mr} \geq A_{sw,min}$$

$$A_{stud,required} = 22.1 \geq 19.4$$

$$A_{stud,required} = 22.1$$

$$10\text{mm } \phi \text{ stud: } A_{stud,provided} = 78.5 \text{ mm}^2 > A_{stud,required}$$

[text deleted]

Stud height

As for 30° radial layout, studs are 200mm high.

45° radial solution:

7 no. main rails (3 x 10mm ϕ studs @ 119mm c/c, 436mm long, 200mm high)

3 no. distribution rails (3 x 10mm ϕ studs @ 119mm c/c, 436mm long, 200mm high)

5 no. distribution rails (2 x 10mm ϕ studs @ 119mm c/c, 317mm long, 200mm high)

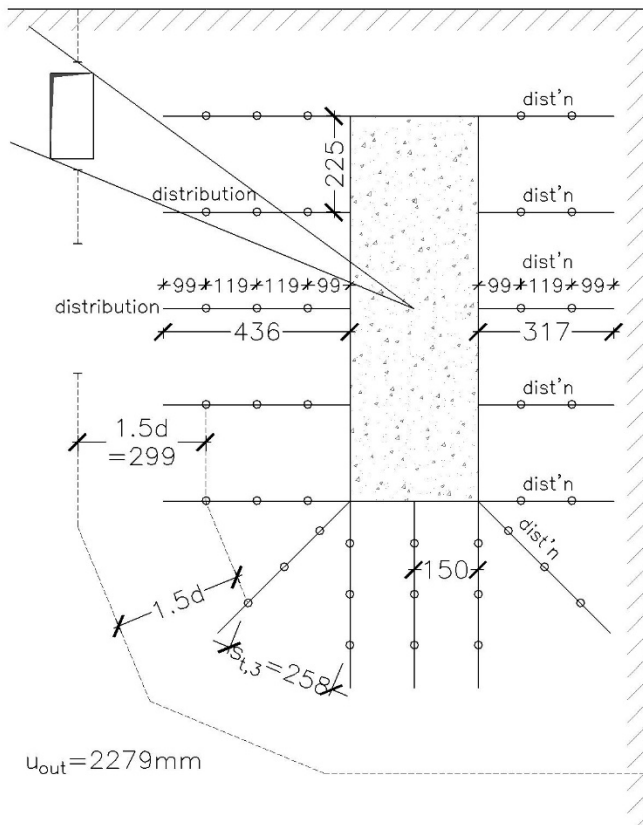

Cruciform layout

[text deleted]

The optimal cruciform layout established by the software contains 6 main rails, with three studs per rail and a radial stud spacing s_r of $0.75d = 149\text{mm}$. The length of each main rail is 496mm . With this arrangement, the length of the outer perimeter is $2305.4\text{mm} \geq 2228\text{mm}$.

Shear stud size

$$A_{sw} = (v_{Ed,1} - 0.75v_{Rd,c})s_r u_1 / 1.5f_{ywd,ef} \quad \text{and} \quad A_{sw,min} \geq 0.08s_r s_t \sqrt{f_{ck}} / 1.5f_{yk}$$

As for 30° radial layout, $A_{sw} = 193.3 \text{ mm}^2 \text{ per perimeter}$

$$s_r = 149 \text{ mm}$$

$$s_t = 248 \text{ mm}$$

$$A_{sw,min} = 23.3 \text{ mm}^2 \text{ per stud}$$

Minimum number of main rail shear studs per perimeter = 6

$$A_{stud} = A_{sw} / n_{mr} \geq A_{sw,min}$$

$$A_{stud} = 32.5 \geq 23.3$$

$$A_{stud,required} = 32.5$$

10mm ϕ stud: $A_{stud,provided} = 78.5 \text{ mm}^2 > A_{stud,required}$

[text deleted]

Stud height

As for 30° radial layout, studs are 200mm high.

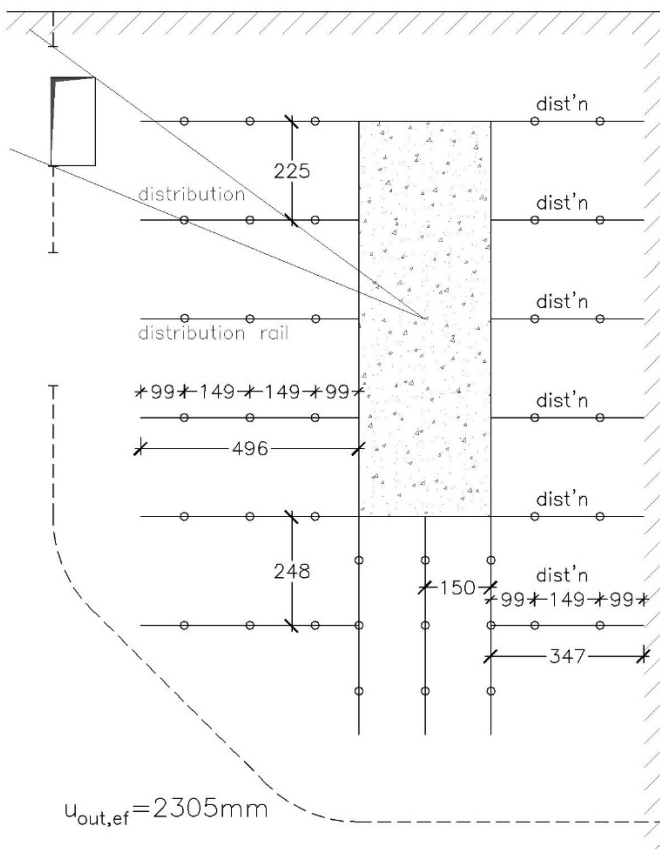

Cruciform solution:

- 6 no. main rails (3 x 10mm ϕ studs @ 149mm c/c, 496mm long, 200mm high)
- 2 no. distribution rails (3 x 10mm ϕ studs @ 149mm c/c, 496mm long, 200mm high)
- 1 no. secondary rail (3 x 10mm ϕ studs @ 149mm c/c, 496mm long, 200mm high)
- 6 no. distribution rails (2 x 10mm ϕ studs @ 149mm c/c, 347mm long, 200mm high)

Optimal layout solution

Layout	Total number of shear studs	Total number of rails
30° radial	54	19
45° radial	40	15
Cruciform	39	15

Optimal solution determined by total number of shear studs and then by total number of rails. The **cruciform layout** requires the smallest number of shear studs, therefore that is the optimal solution.

Shear capacity with punching shear reinforcement

Shear capacity with reinforcement,

$$(6.52) \quad v_{Rd,cs} = 0.75v_{Rd,c} + 1.5\left(\frac{d}{s_r}\right)A_{sw}f_{ywd,ef} \left(\frac{1}{u_1d}\right) \sin \alpha$$

where, $A_{sw} = 6 \times 78.5 = 471 \text{ mm}^2$
 $\alpha = 90^\circ \quad \rightarrow \sin \alpha = 1 \quad \rightarrow v_{Rd,cs} = 1.32 \text{ MPa}$

16.3.3 Design solution

cruciform layout

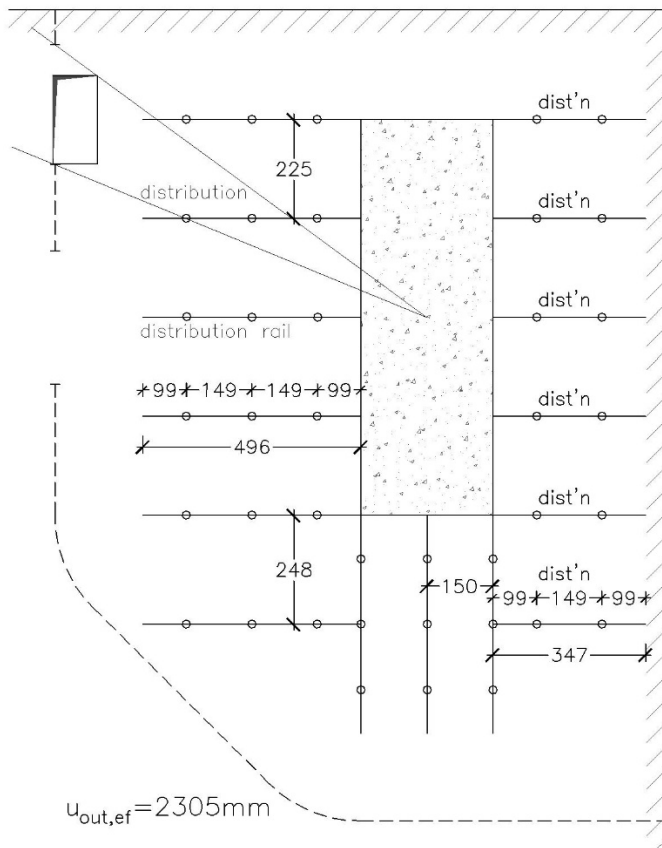

- 6 no. main rails (3 x 10mm ϕ studs @ 149mm c/c, 496mm long, 200mm high)
- 2 no. distribution rails (3 x 10mm ϕ studs @ 149mm c/c, 496mm long, 200mm high)
- 1 no. secondary rail (3 x 10mm ϕ studs @ 149mm c/c, 496mm long, 200mm high)
- 6 no. distribution rails (2 x 10mm ϕ studs @ 149mm c/c, 347mm long, 200mm high)

16.4 Re-entrant corner circular column

16.4.1 Inputs

Re-entrant corner circular column		
Dimensions,		D = 400 mm
	Edge @ left	$a_{e,y} = 200$ mm
	Edge @ top	$a_{e,z} = 200$ mm
Slab depth,		h = 240 mm
Concrete grade,	C40/50	$f_{ck} = 40$ N/mm ²
Top cover,		$c_{nom,t} = 30$ mm
Bottom cover,		$c_{nom,b} = 30$ mm
Pre-compression,		$\sigma_{cp} = 0$ N/mm ²
Reinforcement,	Layer 1,	y-y H12 @150 mm c/c
		z-z H12 @150 mm c/c
	Layer 2,	y-y H12 @200 mm c/c
		z-z H12 @200 mm c/c
Loading	Design shear	$V_{Ed} = 500$ kN
	β	To be calculated
	Design moments	$M_{Ed,y} = 5$ kNm
$M_{Ed,z} = 5$ kNm		Towards interior
Opening 1	Circular	$l_y = 700$ mm
		$l_z = 150$ mm
		$\phi = 150$ mm
		Distance to first stud
Shearfix	Layout	auto
	Stud ϕ	Automatic optimal
	Rail placing	Bottom-up

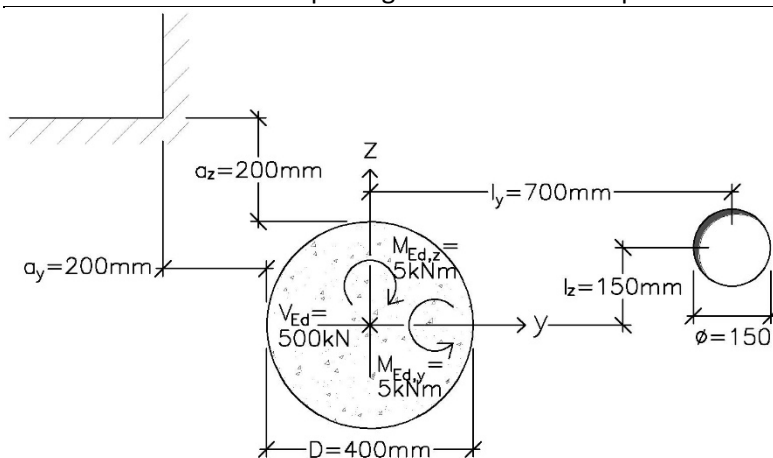

16.4.2 Design

Design parameters

$$\begin{aligned}
 \text{Effective depth,} \quad d_{y1} &= h - c_{nom,t} - \phi_{y1}/2 && = 204\text{mm} \\
 d_{z1} &= h - c_{nom,t} - \phi_{y1} - \phi_{z1}/2 && = 192\text{mm} \\
 d_{y2} &= h - c_{nom,t} - \phi_{y1} - \phi_{z1} - \phi_{y2}/2 && = 180\text{mm} \\
 d_{z2} &= h - c_{nom,t} - \phi_{y1} - \phi_{z1} - \phi_{y2} - \phi_{z2}/2 && = 168\text{mm} \\
 d &= (d_{y1} + d_{z1} + d_{y2} + d_{z2})/4 && = \underline{186\text{mm}}
 \end{aligned}$$

$$\text{Control perimeters,} \quad D_{u0} = \min(0.25\pi D, 1.5d) = \min(314, 279) = 279\text{mm}$$

$$g_y = a_{e,y} + \frac{D}{2} = 400\text{mm}$$

$$g_z = a_{e,z} + \frac{D}{2} = 400\text{mm}$$

$$\text{without opening,} \quad u_0 = 0.5\pi D + 2D_{u0} = \underline{1186\text{ mm}}$$

$$u_1 = \frac{3\pi}{4}(D + 4d) + g_y + g_z = \underline{3495\text{ mm}}$$

$$\text{with opening,} \quad u_0 = \underline{1144\text{mm}}$$

$$u_1 = \underline{3375\text{mm}}$$

$$\begin{aligned}
 \text{Reinforcement ratio,} \quad \rho_{ly} &= \frac{A_{sy1}}{A_{cy1}} + \frac{A_{sy2}}{A_{cy2}} = 0.00683 && \rho_{lz} = \frac{A_{sz1}}{A_{cz1}} + \frac{A_{sz2}}{A_{cz2}} = 0.00729 \\
 \rho_l &= \sqrt{\rho_{ly} \times \rho_{lz}} && = \underline{0.00706} \quad (\equiv 0.706\%)
 \end{aligned}$$

Load increase factor,

Re-entrant corner, therefore:

$$\beta = 1 + k \frac{M'_{Ed} u_1}{V_{Ed} W_1}$$

$$y_0 = 5.3\text{ mm} \quad z_0 = 5.3\text{ mm}$$

(where: +y₀ is in +y direction; +z₀ is in -z direction)

$$M'_{Ed,y} = M_{Ed,y} - z_0 V_{Ed} = 2.35\text{ kNm}$$

$$M'_{Ed,z} = M_{Ed,z} - y_0 V_{Ed} = 2.35\text{ kNm}$$

$$\beta = 1 + k \frac{M'_{Ed} u_1}{V_{Ed} W_1} \rightarrow \underline{\beta = 1.011}$$

Results so far

Effective depth	d =	186	mm
Control perimeters	u ₀ =	1144	mm
	u ₁ =	3375	mm
Reinforcement ratios	ρ _l =	0.00706	
Load increase factor	β =	1.011	

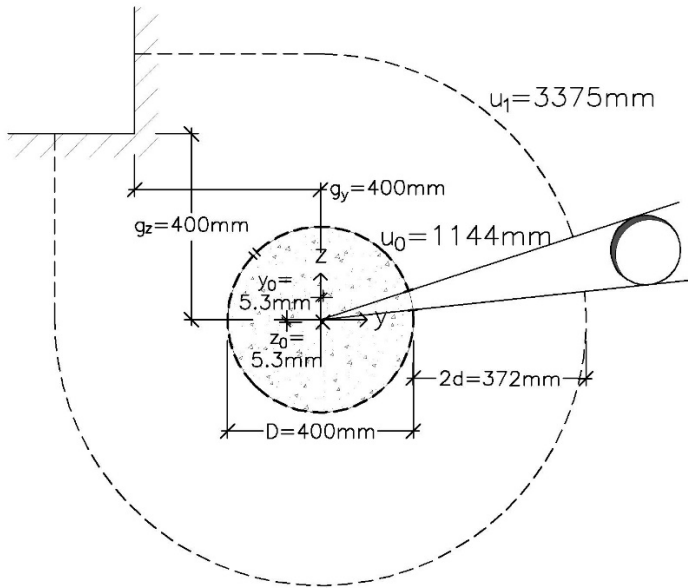

Shear at column face

Applied design shear at column face, (6.53) $v_{Ed,0} = \frac{\beta V_{Ed}}{u_0 d}$ $v_{Ed,0} = 2.38 \text{ MPa}$

Design shear capacity without reinforcement, $v_{Rd,max} = 0.5 v f_{cd}$

where, (6.6N) $v = 0.6 \left[1 - \frac{f_{ck}}{250} \right] = 0.504$

(3.15) $f_{cd} = \frac{\alpha_{cc} f_{ck}}{\gamma_c}$

Table 2.1N $\gamma_c = 1.5$ "persistent and transient"

(3.1.6) $\alpha_{cc} = 1.0$ "all other phenomena"

$f_{cd} = 26.67 \text{ MPa}$ $v_{Rd,max} = 6.72 \text{ MPa}$

CHECK: $v_{Ed,0} \leq v_{Rd,max}$ → OK to proceed with design

Shear at basic control perimeter without reinforcement

Applied design shear at basic control perimeter, (6.38) $v_{Ed,1} = \frac{\beta V_{Ed}}{u_1 d}$ $v_{Ed,1} = 0.81 \text{ MPa}$

Design shear capacity without reinforcement,

(6.47) $v_{Rd,c} = \left[C_{Rd,c} k (100 \rho_l f_{ck})^{1/3} + k_1 \sigma_{cp} \right] \geq (v_{min} + k_1 \sigma_{cp})$

where, $C_{Rd,c} = 0.18 / \gamma_c = 0.12$

$k = 1 + \sqrt{200/d} \leq 2.0$ → $k = 2.0$

$\rho_l = \sqrt{\rho_{lx} \rho_{ly}} \leq 0.02$ → $\rho_l = 0.00706$

(NA6.4.4) $k_1 = 0.1$

(NA6.4.4) $v_{min} = 0.035 k^{3/2} f_{ck}^{1/2} = 0.626$

$v_{Rd,c} = 0.731 \geq 0.626$ $v_{Rd,c} = 0.73 \text{ MPa}$

Limiting value of punching shear capacity, $v_{Rd,c,max} = 2 \times v_{Rd,c}$ $v_{Rd,c,max} = 1.46 \text{ MPa}$

CHECK: $v_{Ed,1} > v_{Rd,c}$ → punching shear reinforcement required

$v_{Ed,1} \leq v_{Rd,c,max}$ → OK to proceed with design

Extent of punching shear reinforcement required

Control perimeter at which reinforcement is no longer required,

$$u_{out,req} = \frac{\beta V_{Ed}}{v_{Rd,c}d}$$

$$u_{out,req} = 3718 \text{ mm}$$

Auto layout

[text deleted]

Length of main rails

Distance to first stud, $s_{r0} = 0.5d = 93 \text{ mm}$
 rounded down to nearest 1mm $\rightarrow s_{r0} = 93\text{mm}$

Radial spacing of studs, $s_r = 0.75d = 139.5 \text{ mm}$
 rounded down to nearest 1mm $\rightarrow s_r = 139\text{mm}$

[text deleted]

The software generates an optimal solution with 10 rails around three quarters of the column face – is. The rails are positioned at 27° spacings.

Secondary rails

Maximum tangential spacing inside basic control perimeter, $1.5d = 279 \text{ mm}$

Stud number	Maximum tangential spacing	Secondary rail required?
3	266 mm	≤ 1.5d secondary rail not required

[text deleted]

Shear stud size

$$A_{sw} = \frac{(v_{Ed,1} - 0.75v_{Rd,c})s_r u_1}{1.5f_{ywd,ef}} \quad \text{and} \quad A_{sw,min} \geq \frac{0.08s_r s_t \sqrt{f_{ck}}}{1.5f_{yk}}$$

where

$$f_{yk} = 500 \text{ MPa}$$

$$f_{ywd,ef} = 250 + 0.25d \leq f_{ywd}$$

$$f_{ywd} = \frac{f_{yk}}{1.15} = 435 \text{ MPa}$$

$$f_{ywd,ef} = 297 \leq 435$$

$$s_r = 139 \text{ mm}$$

$$s_t = 266 \text{ mm}$$

$$A_{sw} = 276.4 \text{ mm}^2 \text{ per perimeter}$$

$$A_{sw,min} = 23.3 \text{ mm}^2 \text{ per stud}$$

Minimum number of effective main rail shear studs per perimeter = 8

$$A_{stud} = \frac{A_{sw}}{n_{mr}} \geq A_{sw,min}$$

$$A_{stud} = 25.1 > 23.3$$

$$A_{stud,required} = 25.1$$

10mm ϕ stud: $A_{stud,provided} = 78.5 \text{ mm}^2 > A_{stud,required}$

[text deleted]

Stud height

$$h_{stud} = h - c_{nom,t} - c_{nom,b}$$

$$h_{stud} = 240 - 30 - 30 = 180 \text{ mm}$$

Therefore, studs are 180mm high.

16.4.3 Design solution

Auto layout

- 11 no. main rails (3 x 10mm ϕ studs @ 139mm c/c, 464mm long, 180mm high)
- 1 no. secondary rails (2 x 10mm ϕ studs @ 139mm c/c, 325mm long, 180mm high)

