

Installation Guide

Thermal Windpost TWP2

Ancon Thermal Windpost TWP2

Panels of masonry with openings or very large masonry panels can be difficult to design. Ancon Thermal Windposts are designed to span vertically between floors to provide additional lateral support for panels of masonry. Ancon Thermal Windposts are also designed to limit the transfer of thermal energy through the post and to aid the fitting of insulation around the post to maintain the insulation line.

Top & Bottom Connections

Top and bottom connections are designed with slotted holes to allow adjustment. Where cast-in channels are used parallel to the slab edge, a serrated pad and washer must be provided. Where expansion bolts are used, round holes or slots parallel to the slab edge will suffice. **The top connection should also have a vertical slot or slots (no serrations) to permit movement of the frame.**

Connections to the structural frame are determined prior to Manufacture/Supply, therefore the following rules should be followed.

1. Only use the fixings supplied, as these are integral to the design.
2. Use all normal/serrated washers provided, and tighten nuts to specified tightening torques (see Installation Guide—Bolts).
3. Dimensional positioning of the windpost should be to either Structural Engineers or Specialist details.
4. Ensure all windposts are installed vertical in both planes, thus allowing the ties to slide in the slots if expansion/contraction of the frame occurs.

If the top connection of the windpost cannot be fixed to the structure upon initial placement of the windpost, it may be necessary to provide temporary support or a prop to hold the top of the windpost in place during construction, until such time that the top connection can be fixed.

Insulation Installation

Cavity wall insulation should be butted hard up to each side of the post and, where the type of insulation allows, taped to the post using a suitable insulation tape.

Designs for partial-fill insulation are based around the outer flange being level with the outside face of the insulation (maximum insulation depth 185mm). The post should be positioned a minimum of 50mm from the outer leaf for both partial and full-fill cavities. In full-fill scenarios it is necessary to carefully cut insulation to fit in front of the post between the flange and the brick, ensuring there are no remaining gaps between adjacent pieces of insulation, or between insulation and post.

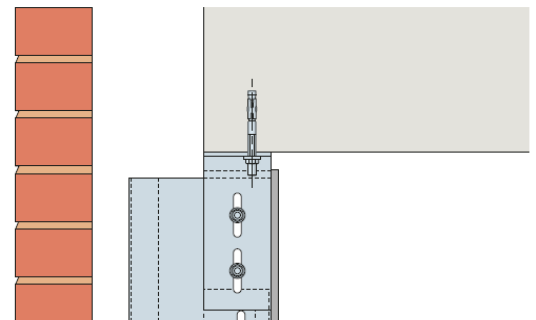

Top connection - Section (side) view

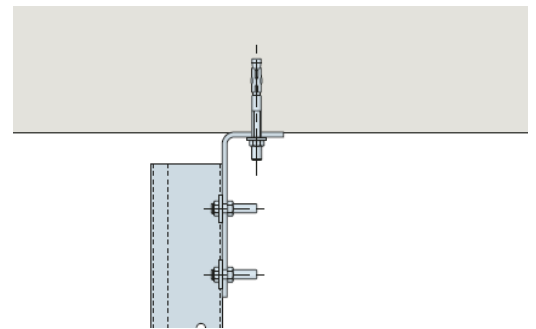

Top connection - Elevation (front) view

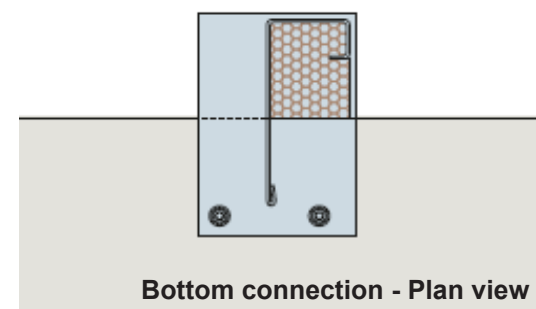

Bottom connection - Plan view

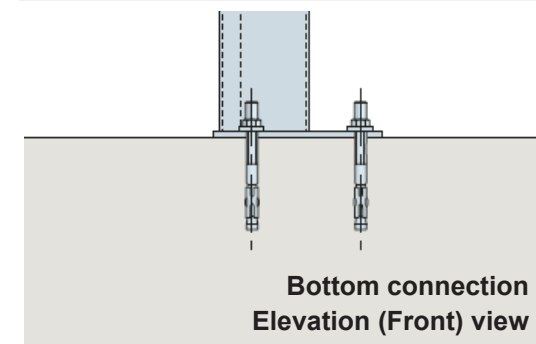
Bottom connection
Elevation (Front) view

Tie Installation and Embedment

Wall ties should be fitted in each slot and have a minimum embedment of 50mm into each leaf. Leviat suggest tie lengths which achieve a recommended embedment of between 62.5mm and 75mm, allowing for tolerance on cavity variations

Ties for the inner leaf (solid mortar joint)

The hem side of the post and the end of the block should be “battered up” with mortar to pack out the space between the block and the web of the post. On the flat side of the post, the block should be hard up to the web with a thin layer of mortar on the end of the block to promote full contact (see Fig. 1). SNS Ties may then be pressed in to fresh mortar on top of the block on both sides of the post, and surrounded by fresh mortar, before laying the next block.

Ties for the inner leaf (movement joint)

The hem side of the post and the end of the block should be “battered up” with mortar to pack out the space between the block and the web of the post. The compressible filler should be positioned on the flat side of the post (see Fig. 2). PNS Ties may then be pressed into fresh mortar on top of the block on both sides of the post with the debonding sleeve applied on the side with the compressible filler, and surrounded by fresh mortar, before laying the next block.

Ties for the outer leaf

The SDN tie simply fits in to the slot provided before being built in to the outer leaf of masonry. An insulation retaining clip should be used where make-up pieces of insulation are required.

For full-fill applications, a Teplo-BF-N windpost tie may be selected at the time of purchase to maximise thermal efficiency. Installation of the Teplo-BF-N is exactly the same as an SDN.

Omitting the outer ties

In some cases the design may call for outer ties to be omitted (see Fig. 3). This reduces the capacity of the section – **refer to Leviat drawings to confirm if the windpost has been designed in this way**. If outer ties are shown on the drawing then they must be installed.

In cases where outer ties are omitted, cavity wall ties should be positioned no greater than 225mm away from the vertical joint on each side, and at a maximum of 225mm vertical spacing. Leviat recommends using the Teplo-BF cavity all tie to maximise thermal efficiency.

Best practice for surrounding restraint

It is best practice to ensure a vertical row of cavity wall ties is placed within 225mm of the vertical joint, at max 450mm vertical spacing (unless outer ties are omitted as noted above, where vertical centres should be no greater than 225mm - see Fig. 3).

Where head restraints are specified, the first head restraint on each side of the windpost should be placed at no greater than 450mm from the vertical joint (see Fig. 4).

Safety Precautions

Ancon stainless steel products are produced from laser cut plate. As with all such industrial fabrications, these may present sharp edges. Whilst the design of the post minimises the exposure of sharp edges, **suitable personal protective equipment should be worn at all times during handling and installation**.

Manual handling and movement of the post on-site must be considered prior to receiving delivery of the posts.

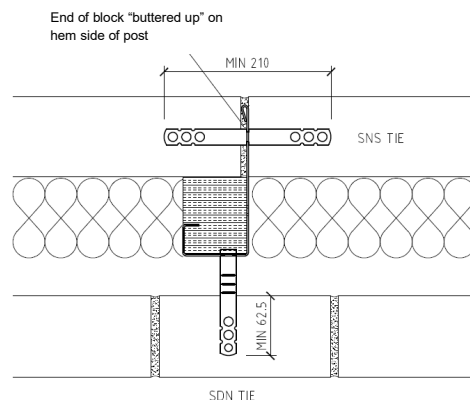

Fig. 1 Ties for the inner leaf (Solid mortar joint)

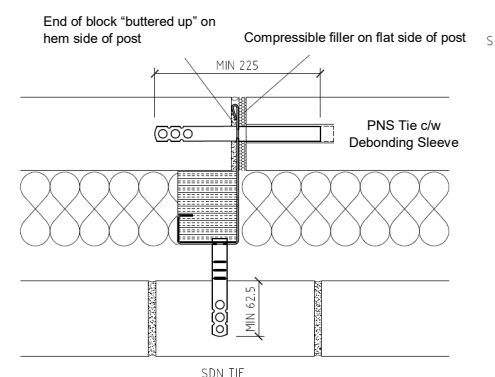

Fig. 2 Ties for the inner leaf (Movement joint)

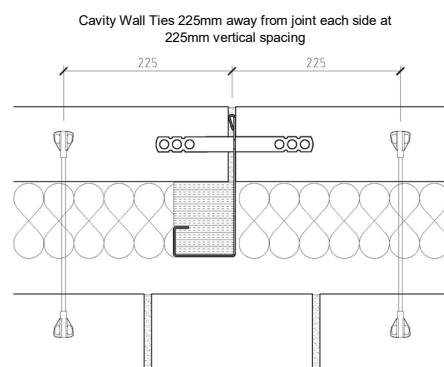

Fig. 3 Omitting the outer ties

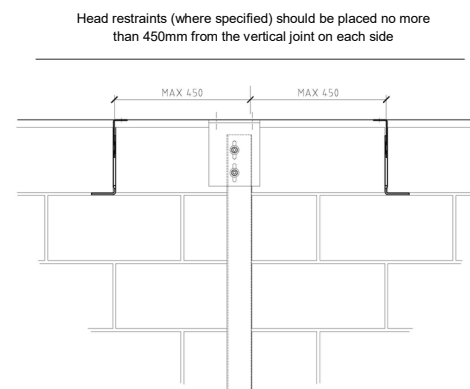

Fig. 4 Best practice for surrounding restraint

The Construction applications and details provided in this guide are indicative only. In every case installation should be entrusted to appropriately qualified and experienced persons. Normal handling precautions should be taken to avoid physical injury. The company cannot be held responsible for any injury as a result of using our products, unless such injury arises as a result of our negligence. © Protected by copyright