

HLD Shear Load Connectors Installation Guide

Installation Procedure

The two-piece design of all Ancon shear load connectors means that holes no longer need to be drilled in the formwork and the position of the dowel is fixed by the sleeve. This makes installation easier and more accurate. HLD and HLDQ shear load connectors are mostly used to transfer vertical loads, so it is important to pay attention to the installation orientation during assembly. Both the dowel and the sleeve components are labeled "up" on one side, and should be installed accordingly. In some applications, however, forces are also transmitted in a non-vertical direction. It is important that the marking (Top) must always be mounted in the load direction!

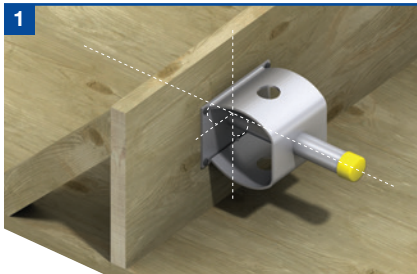
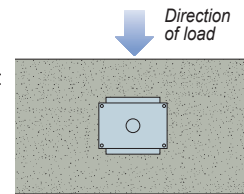

The sleeve component is fixed to the formwork with nails, aligned according to the load direction. Check that the minimum edge and centre distances have been observed. The sticker protects the sleeve component from the penetration of concrete or cement milk and should not be damaged at this stage.

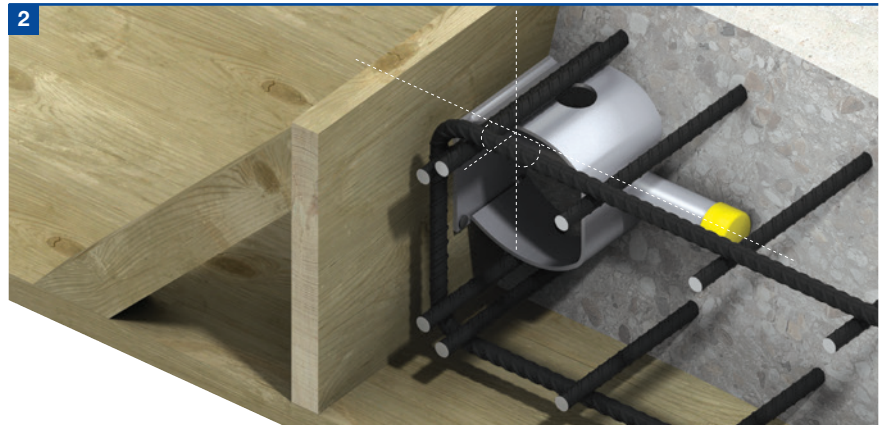

After laying the required reinforcement and a final check to ensure that there is sufficient reinforcement and concrete cover, the concrete can be placed in the formwork. This completes the installation of the sleeve component.



After the concrete has reached sufficient strength, the formwork can be removed. Now the sticker on the installed sleeve component can be removed or pierced and the dowel can be inserted. **Important:** When using transversely movable connectors (HLDQ or ESDQ), the sticker should always be pierced in the middle, so that only the cylindrical sleeve component, which sits centrally in the right-hand corner sleeve, is exposed for the dowel component and the remaining part of the sleeve remains protected.



Now the joint can be lined with joint filling material of suitable thickness.

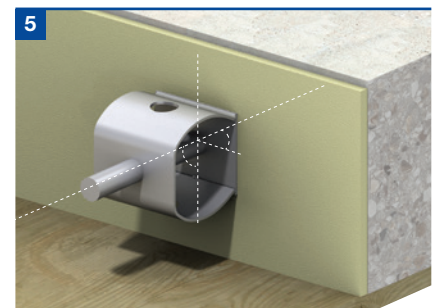

Now press the dowel component through the joint filling material into the installed sleeve as far as it will go. To prevent the dowel component from shifting during concreting, the sleeve is equipped with a small pinch that fixes the dowel component in the installed state. To prevent crushing when inserting the dowel component, light tapping may be necessary.

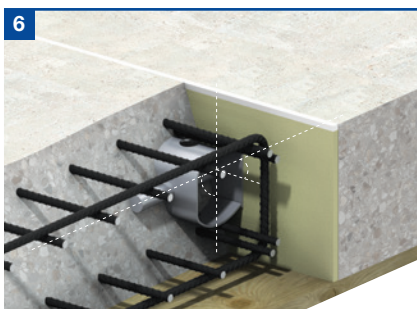

Now the reinforcement can be placed around the dowel, again paying attention to the reinforcement dimensions and the required concrete cover. The installation is completed by placing the concrete.

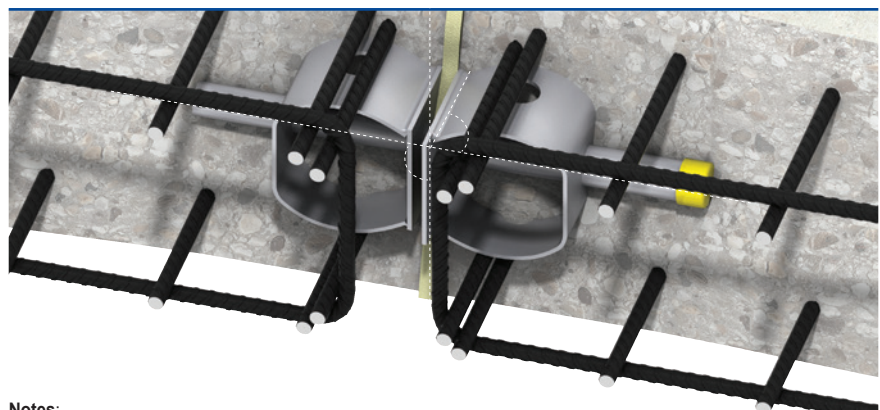

- Notes:**
- (i) Although installation is shown for Ancon HLD, the procedure is the same for all Ancon Shear Connectors.
 - (ii) Where deep concrete pours are proposed, the installation will require further consideration. More robust fixing of the sleeve and dowel components will be necessary, to avoid displacement during placing of the concrete.



For more information on these products, contact:

Leviat

President Way
President Park
Sheffield, S4 7UR
United Kingdom

Tel: +44 (0) 114 275 5224

Fax: +44 (0) 114 276 8543

Email: info.ancon.uk@leviat.com

For sales enquiries:

Email: reinforcement.uk@leviat.com

Ancon.co.uk

Leviat.com

Imagine. Model. Make.

Leviat.com