

## Installation Guide

**Ancon TFMT7 Timber Frame Movement Tie**

Type 7 wall tie for connecting a masonry outer leaf to a structural timber frame

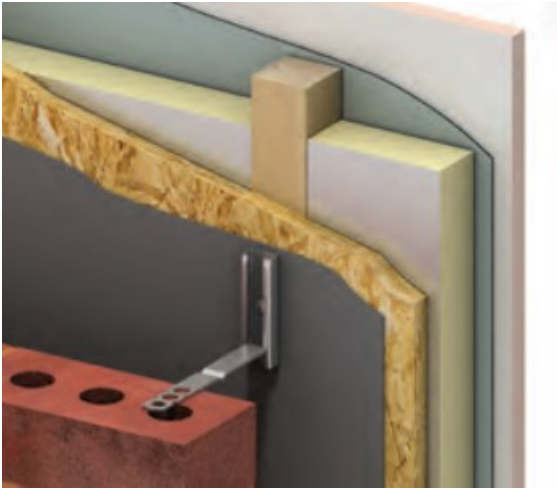

The Ancon TFMT7 is designed to tie masonry (typically brickwork) back to a structural timber frame whilst accommodating differential movement. The system comprises a 90mm long channel, SD25 strip tie and Ø6x50mm hex head coach screw. The TFMT7 can be manufactured to suit any cavity from 50mm to 150mm.

**Important.** The tie should be located 15mm from the bottom of the channel section to ensure the maximum 60mm differential movement is provided.

Full installation procedure:

- Mark up the fixing position. The level should be set to ensure the tie is positioned 15mm from the base of the 90mm long channel section i.e. fixing to be set 30mm above the centreline of the bed joint to be tied.
- Drill a Ø3mm pilot hole in the timber.
- Offer up the channel and align the hole in the channel with the pilot hole. Using a suitable socket wrench or driver with socket adapter, screw in the Ø6x50mm hex head coach screw until the head of the screw is hard up against the back of the channel. The screw should be hand-tight (approx. 5Nm fixing torque).

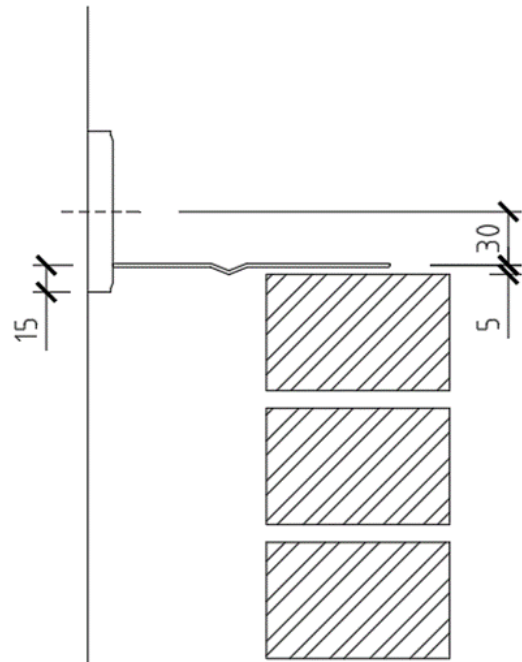

**Note** – The screw should hold the channel in position without it readily spinning or moving. If the channel can spin freely, the screw should be tightened further.

- Insert the SD25 strip tie into the channel and twist to engage both notches on the tie with the channel lips. The tie should be fitted such that the drip points downwards and a minimum of 50mm embedment in the outer leaf is achieved.

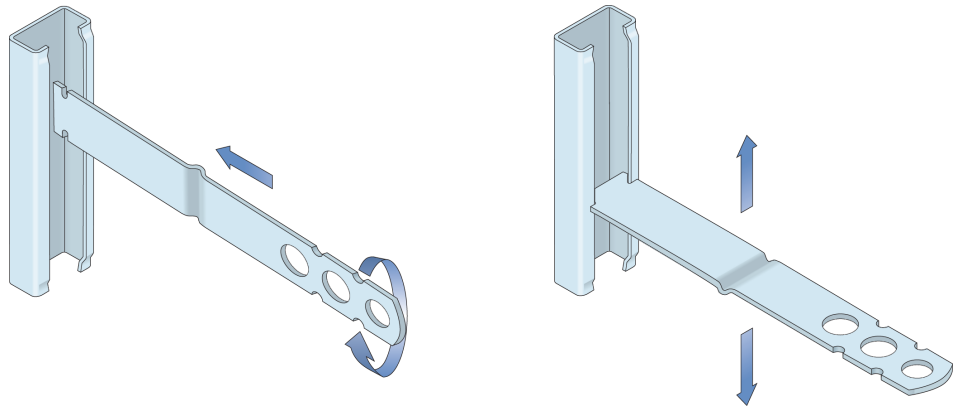

- Press the safety end of the tie firmly down into a layer of fresh mortar and cover with another layer of fresh mortar prior to laying the next brick on top. The starting position of the tie should be 15mm from the base of the channel. Installed ties should be clear of mortar droppings.

The TFMT7 complies with BS 5268-6.1:1996 as a Type 7 timber frame wall tie and has a declared value of 970N. Tie density and maximum design wind loads are shown below.

#### TFMT7 Tie Spacing and Maximum Design Wind Loads

Horizontal centres (mm)	600			
Vertical centres (mm)	225	300	375	450
Tie density (ties/m <sup>2</sup> )	7.41	5.56	4.44	3.70
Max. design wind load (kN/m <sup>2</sup> ULS)	2.40	1.80	1.44	1.20

The Construction applications and details provided in this guide are indicative only. In every case installation should be entrusted to appropriately qualified and experienced persons. Normal handling precautions should be taken to avoid physical injury. The company cannot be held responsible for any injury as a result of using our products, unless such injury arises as a result of our negligence.

© Protected by copyright