

CARES Technical Approval Report TA1-B 5045



Issue 5

Leviat
A CRH COMPANY

Ancon BT Type A Standard and Type C Positional Couplers

Assessment of the
Ancon BT Type A Standard
and Type C Positional Coupler
Product and Quality System
for Production



Product

Ancon BT Type A Standard and Type C Positional Coupler for reinforcing steel

Product approval held by:

Leviat
President Way, President Park
Sheffield S4 7UR
Tel: +44 (0) 114 275 5224
Fax: +44 (0) 114 276 8543
Email: info.ancon.uk@leviat.com
Web: Ancon.co.uk | Leviat.com

1 Product Summary

Ancon BT Type A and Type C couplers in the size range 16mm - 40mm are for the mechanical connection of deformed high-yield carbon steel bars for the reinforcement of concrete complying with the requirements of BS4449 Grade B500C.

1.1 Scope of Application

Ancon BT Type A and Type C couplers in the size range 16mm - 40mm have been evaluated for use as follows:

- a) TA1-B: Eurocode 2 and BS 8110 for static applications in tension only with BS4449 Grade B500C reinforcement.

1.2 Design Considerations

BS 8110 Clause 3.12.8.9 Laps and Joints states "Connections transferring stress may be lapped, welded or joined with mechanical devices. They should be placed, if possible, away from points of high stress and should preferably be staggered". However, BS 8110 Clause 3.12.8.16.2 Bars in tension states "The only acceptable form of full-strength butt joint for a bar in tension comprises a mechanical coupler" satisfying specified slip and tensile strength criteria.

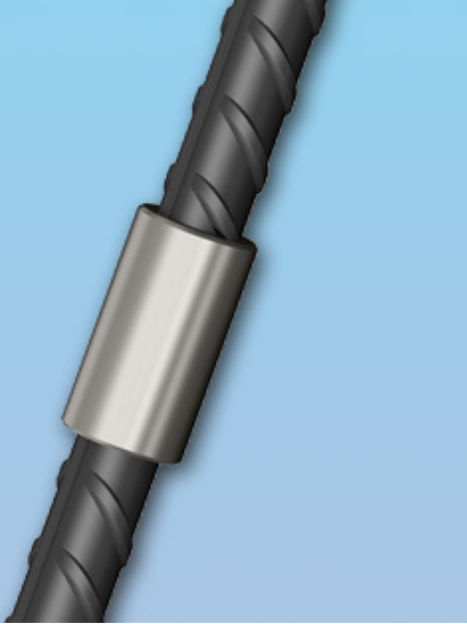

Eurocode 2, Clause 8.7 Laps and mechanical couplers 8.7.1 General (1)P “Forces are transmitted from one bar to another by:

- lapping of bars, with or without bends or hooks;
- welding;
- mechanical devices assuring load transfer in tension-compression or in compression only.”

Clause 8.8 Additional rules for large diameter bars goes on to state that “Splitting forces are higher and dowel action is greater with the use of large diameter bars. Such bars should be anchored with mechanical devices.”

The specified cover for fire resistance and durability should be provided to the coupler sleeve. All couplers have been designed with controlled mechanical properties to be compatible with reinforcing bars complying with reinforcement of the relevant Grade in accordance with BS4449.

1.3 Conclusion

It is the opinion of CARES that Ancon BT Type A and C Couplers in the size range 16mm to 40mm are satisfactory for use within the limits stated in paragraph 1.1 when applied and used in accordance with the manufacturer’s instructions and the requirements of this certificate.

L. Brankley
 Chief Executive Officer
 September 2022

Electronic Copy www.carescertification.com



2 Technical Specification

2.1 General

The function of Ancon BT Types A and C Couplers are to connect deformed steel reinforcing bars complying with BS 4449 Grade B500C as appropriate and thereby create structural continuity of the reinforcing system.

BT couplers offer a full strength connection. Each end of the bar to be joined is cut square and enlarged using a cold forging process. A special thread form is then rolled onto the enlarged bar end. The thread form is such that the cross sectional area of the bar ends is not reduced, thus ensuring the strength of the connection matches or exceeds that of the parent bars.

Each thread rolled bar end is proof loaded to force equal to the characteristic yield strength of the rebar.

2.2 BT Type A Standard Couplers

The Ancon BT parallel thread couplers are an internally threaded steel sleeve. A special parallel thread form is cold rolled onto the ends of the bars being connected. The Type A standard coupler is suitable for applications where the continuation bar can be rotated.

BT Type A Standard Couplers

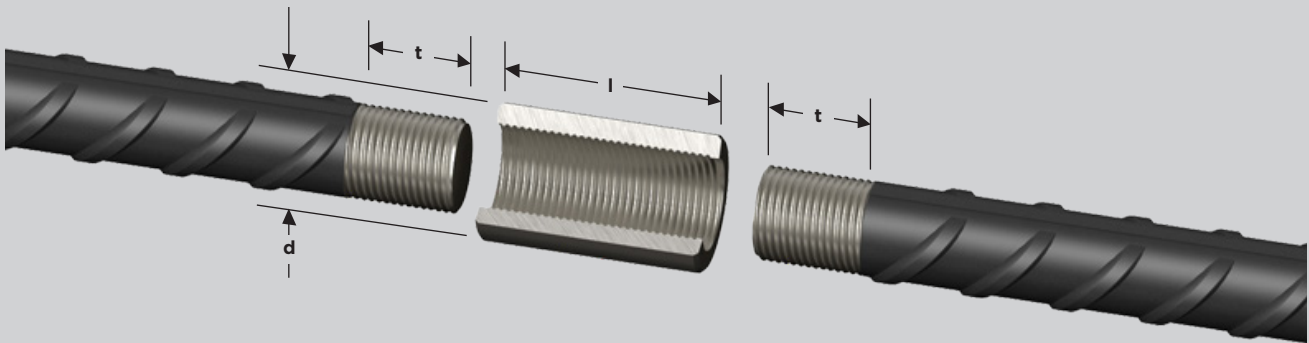

Reinforcing Bar Diameter	16mm	20mm	25mm	32mm	40mm	40mm HS
External diameter, d	26.5	32	40	50	61.9	67.5
Coupler length, l	40	48	60	72	90	90
Thread Size	M20	M24	M30	M36	M45	M45
Thread Pitch	2.5	3.0	3.5	4.0	4.5	4.5
Thread Length, t	20	24	30	36	45	45
Rebar grade	B500C	B500C	B500C	B500C	B500C	B500C
Tension only	✓	✓	✓	✓	✓	✓

Table 1

2.3 BT Type C Positional Couplers

The Ancon BT parallel thread couplers are an internally threaded steel sleeve. A special parallel thread form is cold rolled onto the ends of the bars being connected. The Type C coupler is suitable for applications where the continuation bar cannot be rotated.

BT Type C Positional Couplers

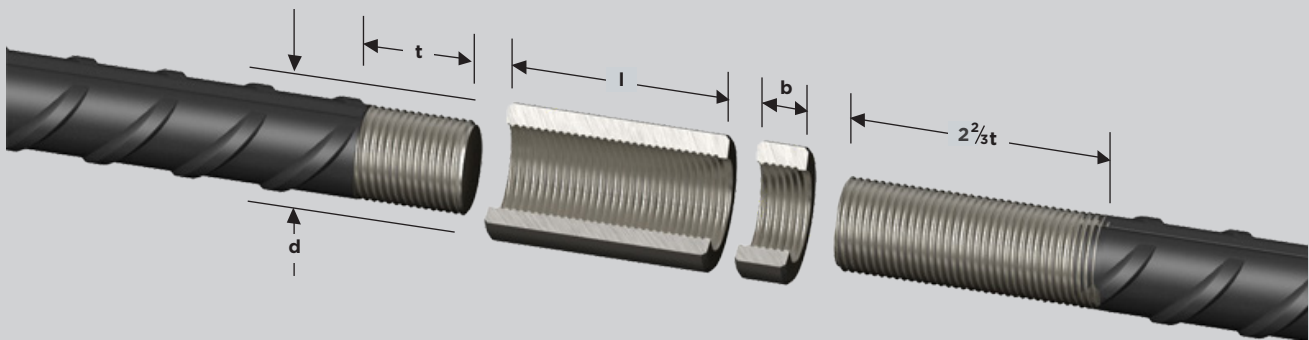

Reinforcing Bar Diameter	16mm	20mm	25mm	32mm	40mm	40mm HS
External diameter, d	26.5	32	40	50	61.9	67.5
Coupler length, l	40	48	60	72	90	90
Thread Size	M20	M24	M30	M36	M45	M45
Thread Pitch	2.5	3.0	3.5	4.0	4.5	4.5
Thread Length, t	20	24	30	36	45	45
Locknut length, b	13	16	20	24	30	30
Rebar grade	B500C	B500C	B500C	B500C	B500C	B500C
Tension only	✓	✓	✓	✓	✓	✓

Table 2

Electronic Copy www.carescertification.com

3 Product Performance and Characteristics

Mechanical tests have been carried out to demonstrate compliance with the performance requirements defined in CARES Appendix TA1-B when used with reinforcing steel BS4449 Grade B500C as appropriate:

CARES APPENDIX TA1-B requirements

- Permanent deformation is less than 0.10mm after loading to $0.65f_y$ in tension with BS4449 grade B500C reinforcement.
- 99% characteristic tensile strength is greater than 575MPa with B500C reinforcement.

4 Installation

BT Type A Standard Couplers

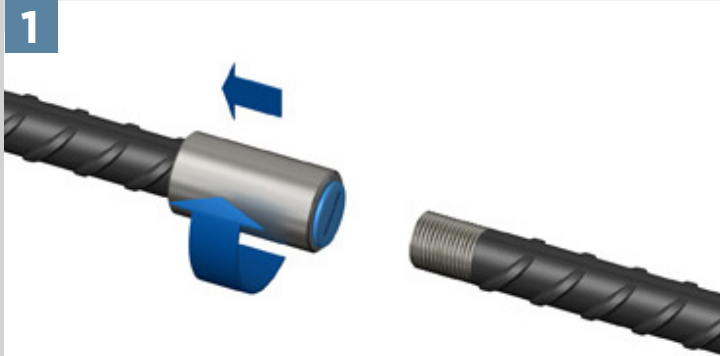

Screw the coupler to the rear of the thread on the fixed bar and lock tight. The bar end should be central within the length of the coupler. Remove the plastic cap from the coupler.

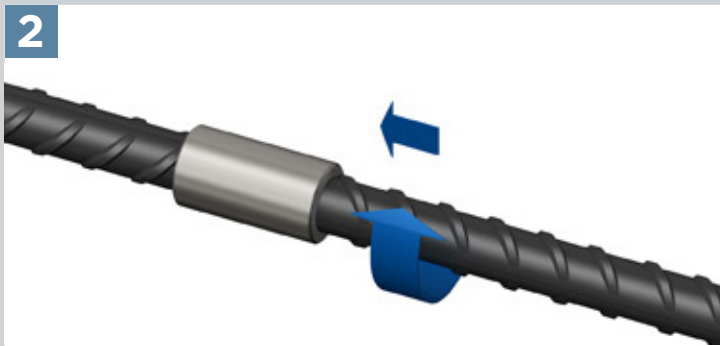

Position and rotate the continuation bar in the coupler.

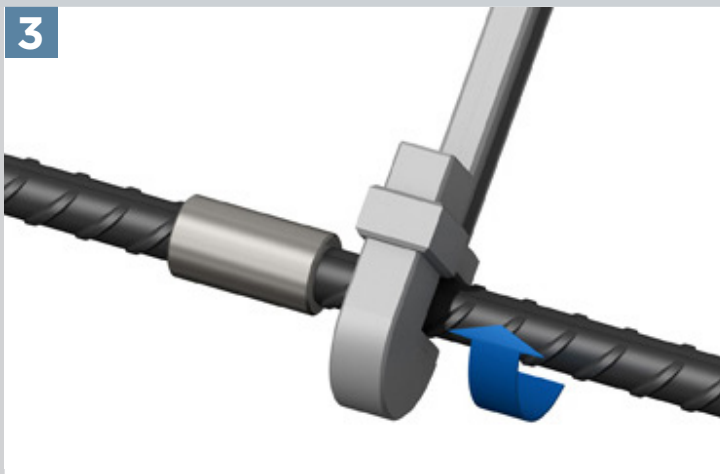

Tighten the joint using a wrench on the continuation bar. After tightening there should be no more than 2 - 4mm of thread exposed, depending on the diameter of the rebar.

BT Type C Positional Couplers

1

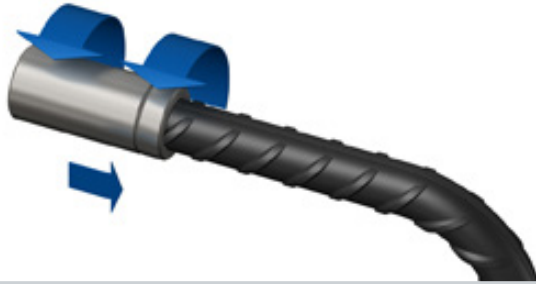

Screw the locknut followed by the coupler to the rear of the thread on the continuation bar.

2



Position the continuation bar with the coupler against the end of the first bar.

3

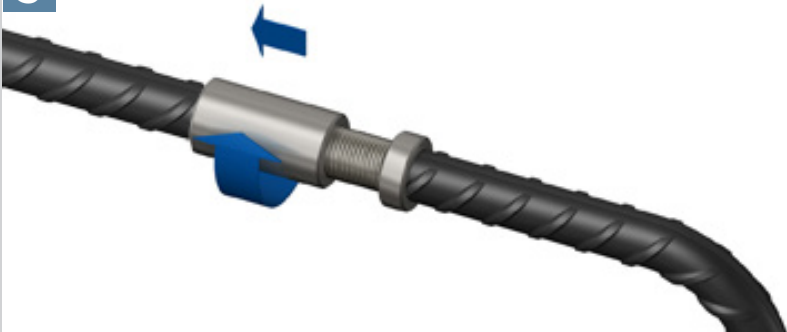

Rotate the coupler from the continuation bar to engage against the rear of the thread on the opposing bar and lock tight.

4



Hold the rebar in the required orientation and with a wrench tighten the locknut against the coupler.

5 Safety Considerations

Ancon BT couplers are generally supplied in robust cardboard cartons. Containers weighing up to 25kg may be handled with care. Heavier cases require the use of mechanical handling equipment. Protective gloves should be work when installing the couplers.

6 Product Testing and Evaluation

Ancon BT Type A Standard and Type C Positional Couplers have been tested to satisfy the requirements of CARES Appendix TA1-B for Couplers with reinforcing bars to BS4449 Grade B500B or C as appropriate. The testing comprised the following elements:

- Tensile Strength
- Permanent deformation in tension

7 Quality Assurance

Ancon BT Type A and Type C Couplers are produced under an EN ISO 9001 quality management system certified by CARES. The quality management system scheme monitors the production of the couplers and ensures that materials and geometry remain within the limits of this technical approval.

The products are also subject to a programme of periodic testing.



8 Building Regulations

8.1 The Building Regulations (England and Wales)

Structure, Approved Document A

Ancon BT Type A Standard and Type C Positional Couplers, when used in EC2 based designs using the data contained within this technical approval, satisfy the relevant requirements of The Building Regulations (England and Wales), Approved Document A.

Materials and Workmanship, Approved Document

This technical approval gives assurance that the Ancon BT Type A Standard and Type C Positional Couplers comply with the material requirements of EC2.

8.2 The Building Regulations (Northern Ireland)

Materials and Workmanship

This technical approval gives assurance that Ancon BT Type A Standard and Type C Positional Couplers comply with the material requirements of EC2 by virtue of regulation 23, *Deemed to satisfy provisions regarding the fitness of materials and workmanship.*

8.3 The Building Standards (Scotland)

Fitness of Materials

This technical approval gives assurance that Ancon BT Type A Standard and Type C Positional Couplers comply with the material requirements of EC2 by virtue of *Clause 0.8.*

Structure

Ancon BT Type A Standard and Type C Positional Couplers, when used in EC2 based designs using the data contained within this technical approval, satisfy the requirements of *The Building Standards (Scotland) clause 1.*

9 References

- BS 4449: 2005: Steel for the reinforcement of concrete - Weldable reinforcing steel - Bar, coil and decoiled product - Specification.
- BS8110: Part 1: 1997: Structural Use of Concrete, Code of Practice for Design and Construction.
- BS EN 1992-1-1:2004 Eurocode 2 Design of concrete structures - General rules for buildings.
- BS EN ISO 9001: Quality management systems - Requirements.
- CARES Appendix TA1-B; Quality and Operations Schedule for the Technical Approval of Couplers for Reinforcing Steel For BS8110 and EN1992-1-1 Applications for Static Loading in Tension or Tension and Compression.



10 Conditions

1. The quality of the materials and method of manufacture have been examined by CARES and found to be satisfactory. This Technical Approval will remain valid provided that:
 - a) The product design and specification are unchanged.
 - b) The materials, method of manufacture and location are unchanged.
 - c) The manufacturer complies with CARES regulations for Technical Approvals.
 - d) The manufacturer holds a valid CARES Certificate of Product Assessment.
 - e) The product is installed and used as described in this report.
2. CARES make no representation as to the presence or absence of patent rights subsisting in the product and/or the legal right of Leviat to market the product.
3. Any references to standards, codes or legislation are those which are in force at the date of this certificate.
4. Any recommendations relating to the safe use of this product are the minimum standards required when the product is used. These requirements do not purport to satisfy the requirements of the Health and Safety at Work etc Act 1974 or any other relevant safety legislation.
5. CARES does not accept any responsibility for any loss or injury arising as a direct or indirect result of the use of this product.
6. This Technical Approval Report should be read in conjunction with CARES Certificate of Product Assessment No 5045. Confirmation that this technical approval is current can be obtained from CARES.



Electronic Copy www.carescertification.com

CARES

Pembroke House
21 Pembroke Road
Sevenoaks
Kent TN13 1XR

Phone: +44(0)1732 450000
E-mail: general@carescertification.com
www.carescertification.com



**Independent Product Assessments
for the Construction Industry**

Copyright CARES ©