

**Leviat®**

International Version

CI/SIB	(29)	Et6	
May 2026			



# Ancon®

## Tapered Thread Couplers

for the Construction Industry

# Leviat

We imagine, model and make engineered products and innovative construction solutions that help turn architectural visions into reality and enable our construction partners to build better, safer, stronger and faster.

**Leviat is a world leader in connecting, fixing, lifting and anchoring technology.**

From the build of new schools, hospitals, homes and infrastructure, to the repair and maintenance of heritage structures, our engineering skills are making a difference around the world.

We provide technical design assistance at every stage of a project, from initial planning to installation and beyond.

Our technical support services range from simple product selection through to the development of a fully customised project-specific design solution.

Every promise we make locally, has the commitment and dedication of our global team behind it. We employ almost 3,000 people at 60 locations across North America, Europe and Asia-Pacific, providing an agile and responsive service worldwide.



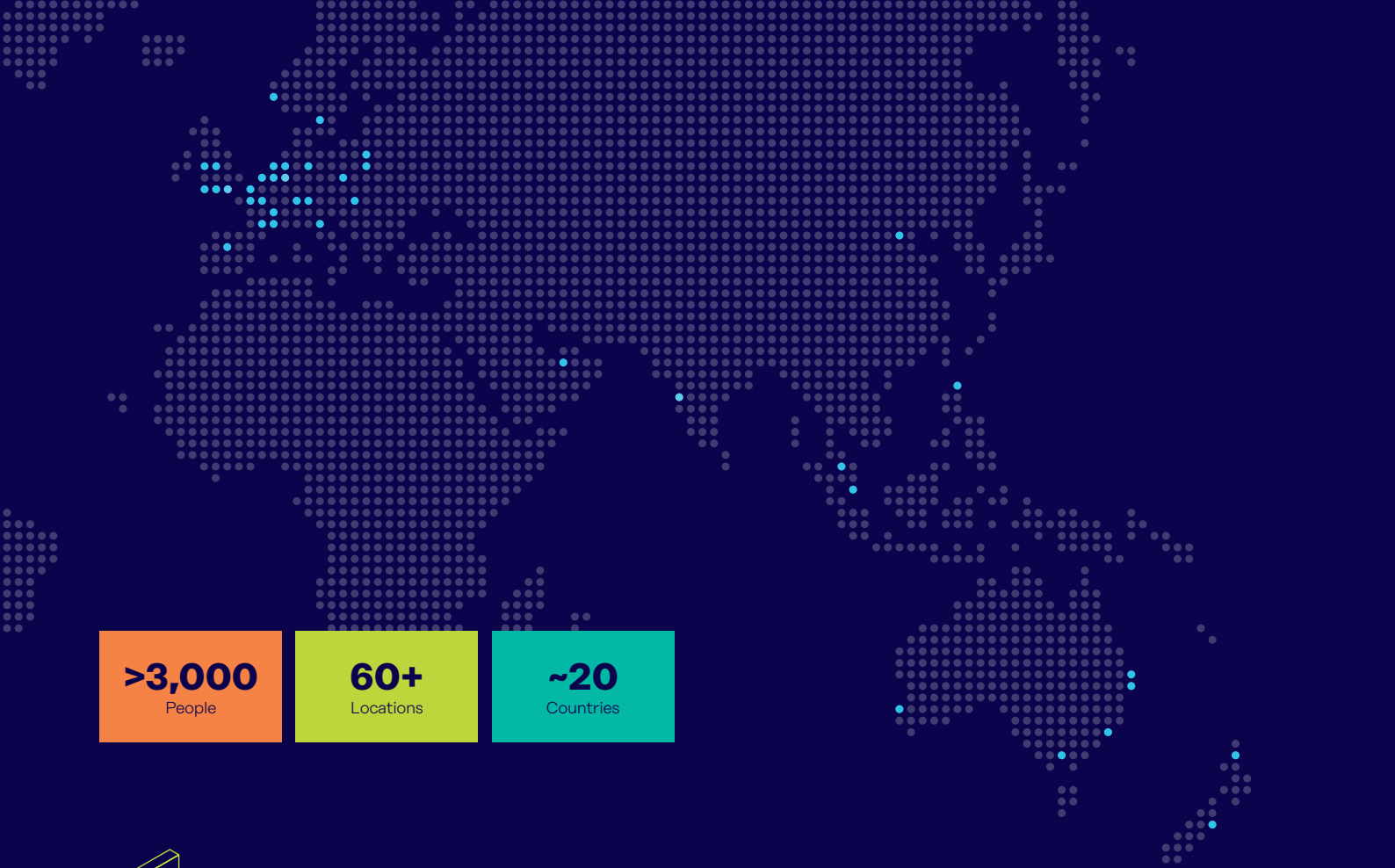

**>3,000**  
People

**60+**  
Locations

**~20**  
Countries

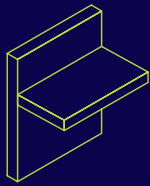

### Structural Connections

Systems to form robust, efficient connections, and continuity of concrete reinforcement as necessary, between walls, slabs, columns, beams and balconies, providing structural integrity as well as enhanced thermal and acoustic performance.

- Insulated balcony connectors
- Reinforcing bar couplers
- Concrete Connections
- Reinforcement continuity systems
- Punching shear reinforcement
- Shear load connectors
- Floor Joint Systems
- Precast / Reinforced Columns
- Infrastructure Products
- Precast Connections
- Acoustic dowels and bearings
- Prestress

### Other areas of expertise:

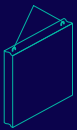

#### Lifting & Bracing

Systems for the safe and efficient transportation, lifting and temporary bracing of cast concrete elements and tilt-up panels before permanent structural connections are made.

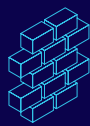

#### Façade Support & Restraint

Systems for the safe and thermally-efficient fixing of the external building envelope, including brick and natural stone, insulated sandwich panels, curtain walling and suspended concrete façades, and also the repair and strengthening of existing masonry installations.

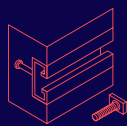

#### Anchoring & Fixing

Systems for fixing secondary fixtures to concrete, including anchor channels, bolts and inserts; also tension rod systems for roofs and canopies.



#### Formwork & Site Accessories

Non-structural accessories that complement our engineered solutions and help keep your construction environment operating safely and efficiently, including moulds for casting standard and special concrete elements and construction essentials such as reinforcing bar spacers.

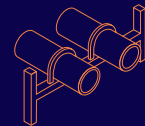

#### Industrial Technology

Mounting channels, pipe clamps and other versatile framing systems that provide safe fixing in a wide range of industrial applications.

### Leviat product ranges:

Ancon | Aschwanden | Connolly | Halfen | Helifix | Isedio | Meadow Burke | Modersohn | Moment | Plaka | Scaldex | Thermomass

# Reinforcing Bar Couplers

Simplify the design and construction of concrete

Lapped joints are not always an appropriate means of connecting reinforcing bars. The use of laps can be time consuming in terms of design and installation and can lead to greater congestion within the concrete because of the increased amount of rebar used.

Ancon couplers can simplify the design and construction of reinforced concrete and reduce the amount of reinforcement required.

Lapped joints are dependent upon the concrete for load transfer. For this reason any degradation in the integrity of the concrete could significantly affect the performance

of the joint. The strength of a mechanical splice is independent of the concrete in which it is located and will retain its strength despite loss of cover as a result of impact damage or seismic event.

The range of Ancon reinforcing bar couplers is the most comprehensive available and includes tapered threaded, parallel threaded, mechanically bolted couplers and grouted couplers.

Couplers for stainless steel and cryogenic-grade rebars complete the range.

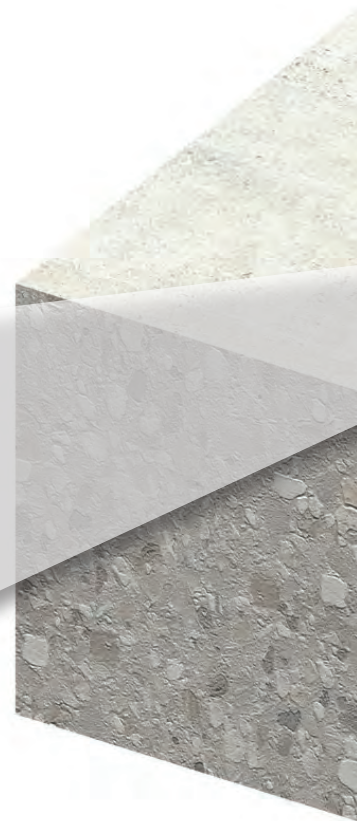

## Contents

<a href="#">Tapered Thread Standard Series</a>	<a href="#">4-5</a>
<a href="#">Tapered Thread Positional Series</a>	<a href="#">6-7</a>
<a href="#">Tapered Thread Transition Series</a>	<a href="#">8</a>
<a href="#">Tapered Thread Weldable Couplers</a>	<a href="#">9</a>
<a href="#">Tapered Thread Headed Anchors</a>	<a href="#">10</a>
<a href="#">Accessories</a>	<a href="#">11</a>
<a href="#">Other Products</a>	<a href="#">11</a>



**Eurocode 2 compliant**



**Simplify design and construction**



**Reduce amount of reinforcement required**



**Available through major rebar stockists and approved distributors**



**Dedicated sales support**



**Technical approval TA1-B 5015**

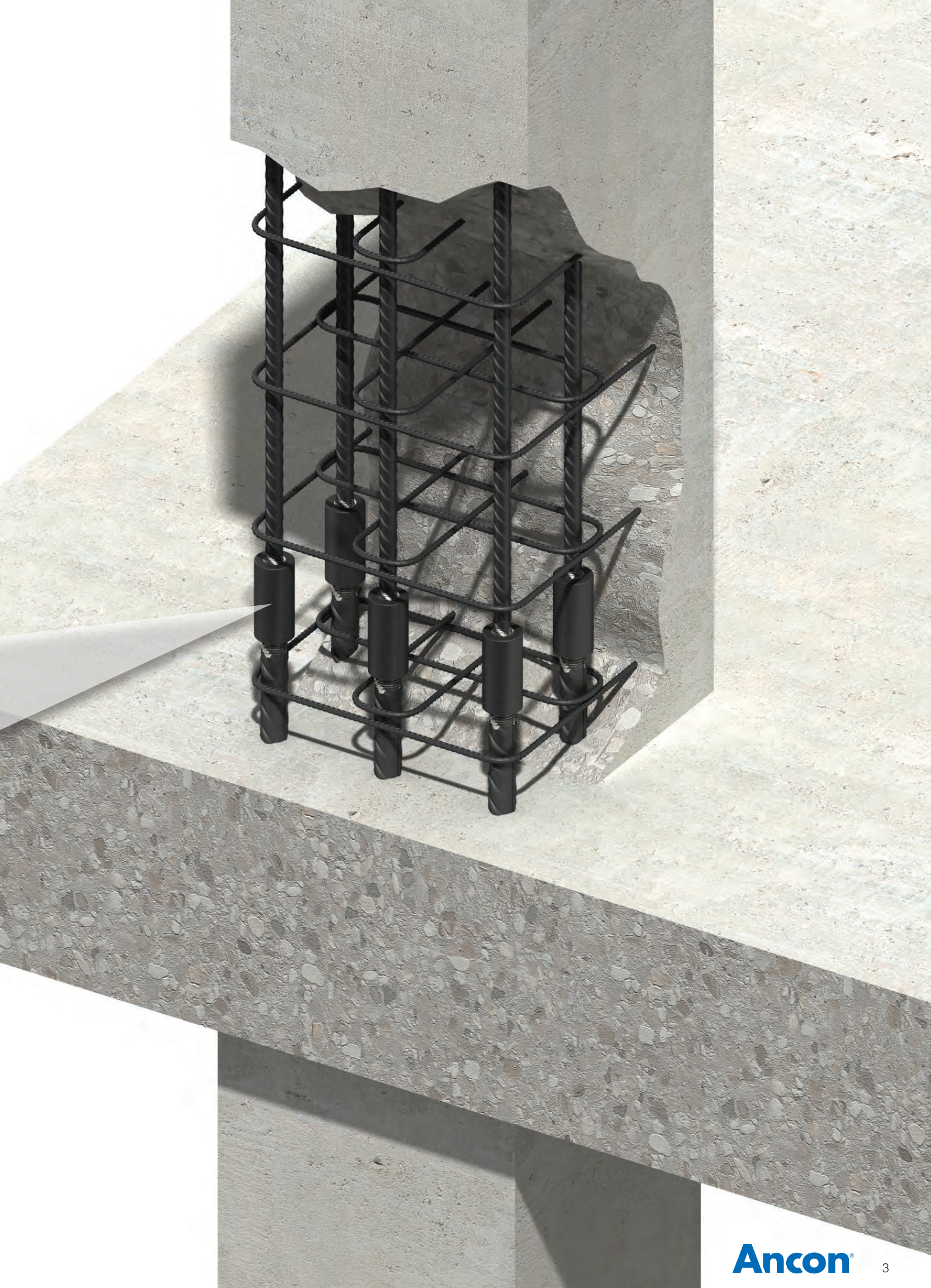

# Reinforcing Bar Couplers

## Tapered Thread

The Ancon range of Tapered Thread couplers is designed to suit the majority of applications which call for the joining of reinforcing bars. Available to suit bar sizes 12mm to 50mm, the couplers are installed quickly and easily on site without the need for specially trained personnel or specialised, expensive machinery.

The compact design of each coupler ensures suitability for use in confined situations where space is restricted or where the loss of cover must be minimised. The couplers are normally supplied fitted to the end of threaded bar, requiring only the engagement and tightening of the adjoining bar on site. In order to ensure correct installation, we specify the use of a torque wrench. The range of Tapered Thread couplers is available through major rebar suppliers. Please contact us for further details.

## Standard Coupler

The Standard Tapered Thread coupler is suitable for connecting two bars of the same diameter, where one bar can be rotated. It comprises an internally threaded sleeve with two right hand threads which are tapered towards the middle of the coupler. The bar ends are square cut and a tapered thread is cut onto the bar. A nominal allowance of +25mm should be allowed per threaded bar end for square cutting the bar end.

The couplers are generally torqued onto the reinforcing bar in the bar threading shop, the internal threads protected by plastic end caps. The threaded ends of the continuation bar are protected by plastic thread protectors.

Engagement of the bar within the coupler is simplified by the tapered thread design which aids alignment. When the bar is fully engaged within the coupler, the continuation bar is tightened using a torque wrench.

The Ancon standard Tapered Thread coupler is compliant with a range of structural design codes and standards, including but not limited to BS 8597:2015.

They are designed to achieve failure loads in excess of 115% of the characteristic strength of grade 500 rebar.

## Standard Coupler Dimensions

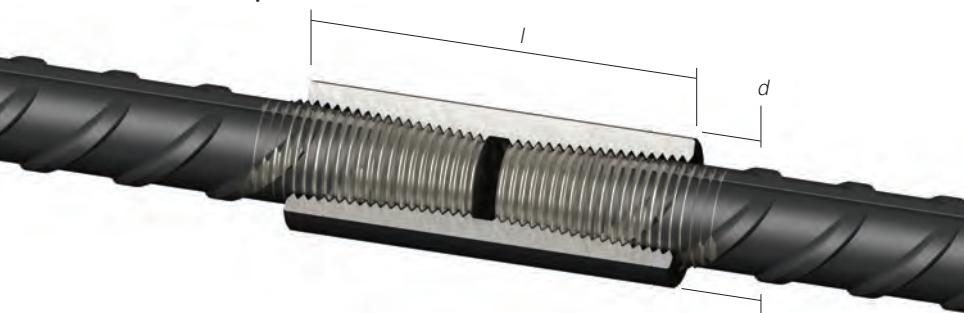

Bar Diameter (mm)		12	14	16	18	20	22	24	25	26	28	30	32	34	36	40	50
External Dia. (mm)	<i>d</i>	22	22	25	28	30	32	36	36	40	42	45	48	55	55	60	70
Coupler Length (mm)	<i>l</i>	58	64	70	72	74	81	87	90	94	100	106	112	119	126	138	170
Weight (kg)		0.13	0.12	0.17	0.22	0.25	0.31	0.43	0.43	0.59	0.66	0.82	0.99	1.50	1.50	1.90	2.91
Torque (Nm)		60	85	110	135	165	205	250	265	270	275	280	285	295	305	330	350
Part No.		TTS12	TTS14	TTS16	TTS18	TTS20	TTS22	TTS24	TTS25	TTS26	TTS28	TTS30	TTS32	TTS34	TTS36	TTS40	TTS50

## Testing and Approvals

The Standard range of Tapered Thread couplers has been independently tested to demonstrate compliance with the following codes:

UK CARES TA1-B Approval No 5015 - BS EN 1992-1-1: 2004 (Eurocode 2) and BS 8110

DIBt Approval No. Z-1.5-179 - Sections 12.6 and 12.8 of DIN 1045-1:2008-08 and Sections 8.4 and 8.7 of DIN EN 1992-1-1/NA.

ÜA Approval No. R-2.1.9-17-15658

RISE Approval No. 0425/02

ITB Approval No. AT-15-9037/2013

IGQ (certificate P192)

KOMO KIWA (certificate K75951/04)

**Note:** Not all coupler types, sizes and torque values are relevant to the national approvals shown. For details of coupler types and sizes relevant to each national approval please refer to the relevant approval document, which is available on request.





**Installation**  
**Tapered Thread Standard Series**



1 The coupler is normally supplied fixed to the reinforcing bar, ready to be installed and cast in concrete.

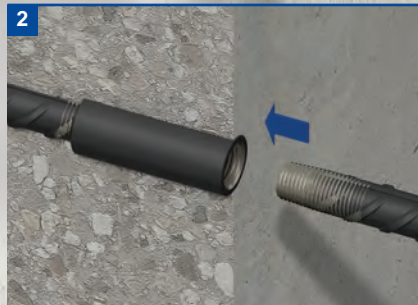

2 After casting the concrete and when ready to extend, remove the plastic end cap from the coupler. Position the continuation bar in the sleeve and rotate the bar into the coupler.



3 Continue to screw the bar into the coupler until tight.

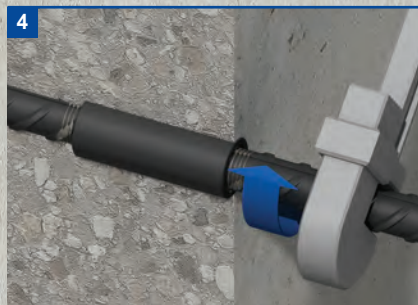

4 To ensure correct installation, tighten the joint to the specified torque using a calibrated torque wrench on the continuation bar. Tightening torques are shown in the table opposite.

# Reinforcing Bar Couplers

## Positional Coupler

The Ancon Tapered Thread Positional coupler is designed to be used in applications in which neither bar can be rotated. Having a degree of adjustability, the Positional coupler can also be used as a closer between two fixed bars.

The Positional coupler comprises three components, a male section, a female section and a locking nut. The male component has an internal tapered thread and an extended external parallel thread. The female component has a parallel thread and a tapered thread, both of which are internal. A locknut is used to secure the connection when the correct degree of adjustability has been achieved. All components, including the locknut must be tightened using a torque wrench. Plastic thread protectors are used to prevent damage to the threaded bar ends and the internal threads of the couplers are protected by plastic end caps. A nominal allowance of +25mm should be allowed per threaded bar end for square cutting the bar end.

### Testing & Approvals

The Positional range of Tapered Thread couplers has been independently tested to demonstrate compliance with the following codes:

UK CARES TA1-B Approval No 5015 - BS EN 1992-1-1: 2004 (Eurocode 2), BS 8110 and BS 8597: 2015

DIBt Approval No. Z-1.5-179 - Sections 12.6 and 12.8 of DIN 1045-1:2008-08 and Sections 8.4 and 8.7 of DIN EN 1992-1-1/NA.

ÚA Approval No. R-2.1.9-17-15658

RISE Approval No. 0425/02

ITB Approval No. AT-15-9037/2013

KOMO (KIWA) Approval No. K75951/03

**Note:** Not all coupler types, sizes and torque values are relevant to the national approvals shown. For details of coupler types and sizes relevant to each national approval please refer to the relevant approval document, which is available on request.

### Positional Coupler Dimensions

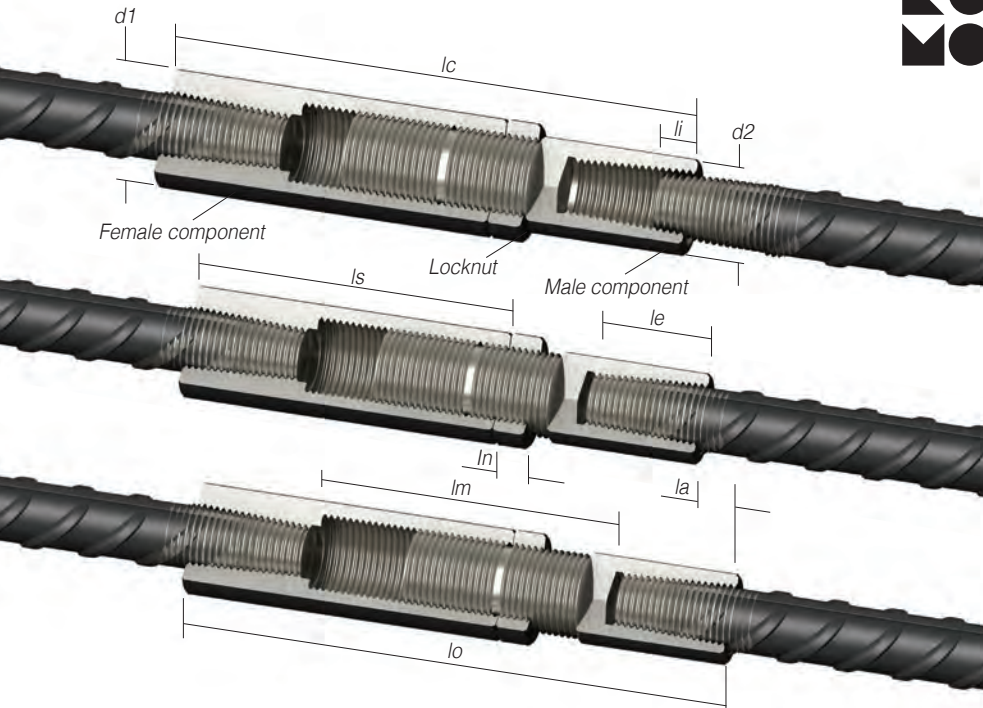

Bar Diameter (mm)		12	14	16	18	20	22	25	26	28	30	32	34	36	40	50
External Dia. (mm)	d1	25	25	30	36	36	42	48	48	50	55	55	60	70	70	85
External Dia. (mm)	d2	22	22	25	28	30	32	36	40	42	45	48	55	55	60	70
Female Sleeve Length	ls	84	89	95	95	112	120	132	136	137	147	153	164	190	190	233
Locknut Length	ln	13	13	13	13	13	13	13	13	13	15	15	15	15	15	16
Closed Length	lc	138	150	155	156	180	191	207	213	218	234	243	261	296	296	359
Max. Open Length	lo	178	190	196	195	231	245	266	273	274	295	305	328	373	374	454
Bar Insertion Prior to Engagement	li	9	12	15	18	8	11	16	18	22	25	28	31	34	40	54
Bar Insertion Full Engagement	le	26	29	32	32	33	37	42	44	47	50	53	56	58	66	82
Adjustable Length	la	23	23	24	25	26	28	34	34	34	36	37	42	54	52	67
Max Distance between Bar Ends	lm	126	124	132	131	165	171	182	185	174	195	199	216	257	242	290
Weight (kg)		0.44	0.67	0.67	0.95	1.12	1.56	2.21	2.18	2.30	3.34	3.51	4.66	6.83	6.91	11.96
Coupler Torque (Nm)		60	85	110	135	165	205	265	270	275	280	285	295	305	330	350
Locknut Torque (Nm)		20	25	30	40	50	60	70	80	80	85	90	100	105	110	130
Part No.		TTP12	TTP14	TTP16	TTP18	TTP20	TTP22	TTP25	TTP26	TTP28	TTP30	TTP32	TTP34	TTP36	TTP40	TTP50

## Installation

### Tapered Thread Positional Series



The female section of the positional coupler is normally cast flush in the concrete. The installer must take care to protect the internal threads and prevent the ingress of concrete. Once cast and ready to extend, the male end complete with locknut can be screwed into place.



Position the continuation bar as near as possible to the coupler fitted to the cast-in bar.

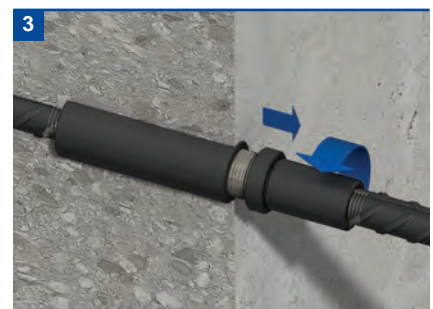

Run the male component and locknut onto the continuation bar until fully engaged.





Using a torque wrench tighten the male component on the continuation bar to the specified torque, whilst holding the continuation bar with a second wrench.



Run the locknut along the threaded barrel of the male component to abut the female section. Using the torque wrench, tighten the locknut to the specified torque. Tightening torques are shown in the table opposite.

At this point the groove in the parallel threaded section of the male component must be completely covered by the locknut. If any part of the groove is visible beyond the locknut, the degree of adjustability has been exceeded and the installation is incorrect.

#### Correct Installation

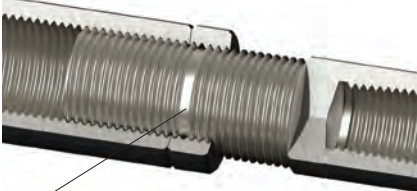

*Groove is completely hidden within locknut*

#### Incorrect Installation

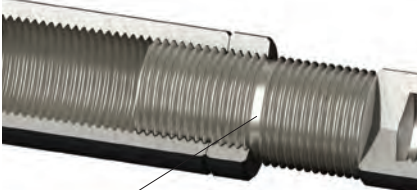

*Groove is protruding from locknut*

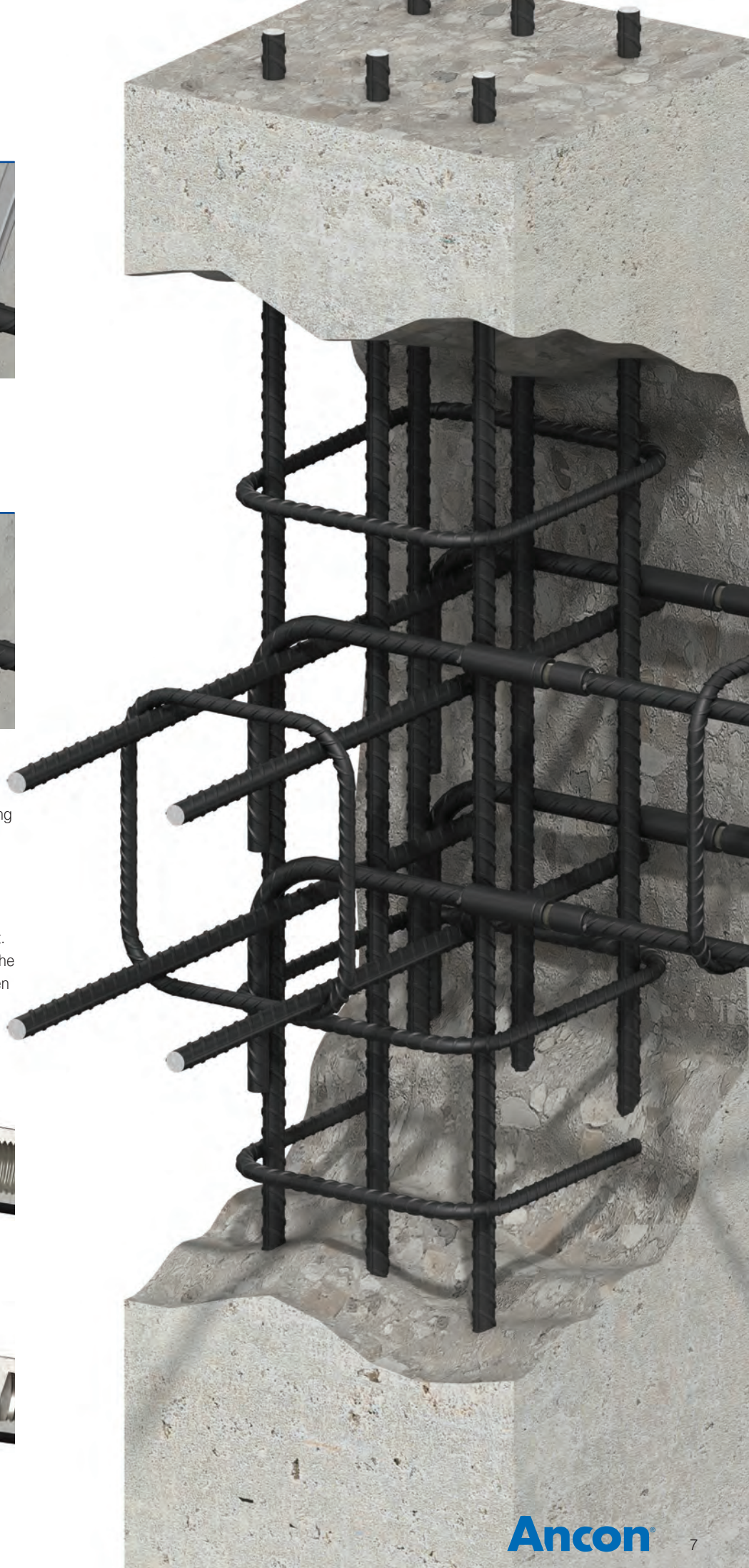

# Reinforcing Bar Couplers

## Transition Coupler

The Ancon Tapered Thread Transition coupler is used to join reinforcing bars of different diameters where one coupler can be rotated.

With all the benefits of the Standard range, Transition couplers are designed to achieve failure loads greater than the national code requirement of the smaller diameter grade 500 reinforcing bar.

The Transition coupler comprises an internally threaded sleeve with two right hand threads both of which are tapered towards the middle of the coupler.

The diameter of each thread corresponds to the appropriate bar size. A nominal +25mm should be allowed per threaded bar end for square cutting the bar end.

## Testing & Approvals

The Transition range of Tapered Thread couplers has been independently tested to demonstrate compliance with the following codes:

UK CARES TA1-B Approval No 5015 - BS EN 1992-1-1: 2004 (Eurocode 2) and BS 8110

DIBt Approval No. Z-1.5-179 - Sections 12.6 and 12.8 of DIN 1045-1:2008-08 and Sections 8.4 and 8.7 of DIN EN 1992-1-1/NA.

ÜA Approval No. R-2.1.9-17-15658

RISE Approval No. 0425/02

KOMO KIWA certificate No. K75951/04



**Note:** Not all coupler types, sizes and torque values are relevant to the national approvals shown. For details of coupler types and sizes relevant to each national approval please refer to the relevant approval document, which is available on request.

## Installation

### Tapered Thread Transition Series

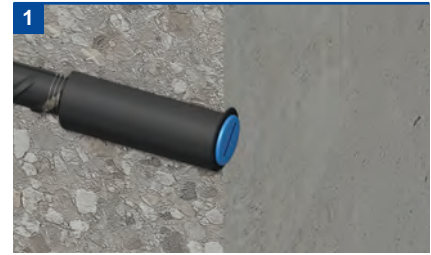

The coupler is normally supplied fixed to a reinforcing bar, ready to be installed and cast in concrete.

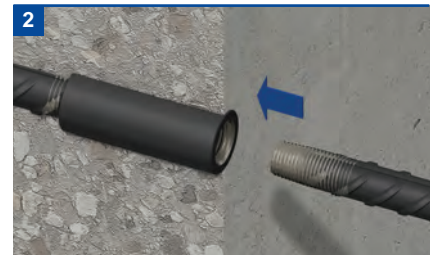

After casting of the concrete and when ready to extend, remove the plastic end cap from the coupler. Position the continuation bar in the sleeve and rotate the bar into the coupler.

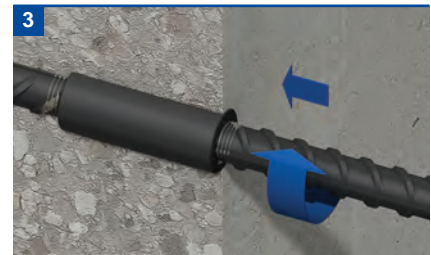

Continue to screw the bar into the coupler until tight.

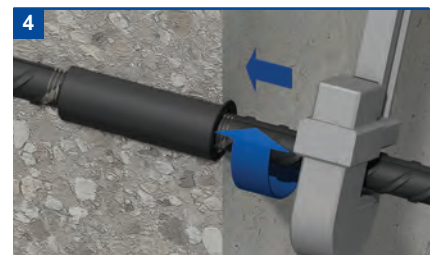

To ensure correct installation, tighten the joint to the specified torque using a calibrated torque wrench on the continuation bar. Tightening torques are shown in the table below.

**Note:** In the event of the coupler being supplied fixed to the smaller bar it is necessary to ensure that when tightening the larger continuation bar, the force is not transmitted through the smaller bar.

## Transition Coupler Dimensions

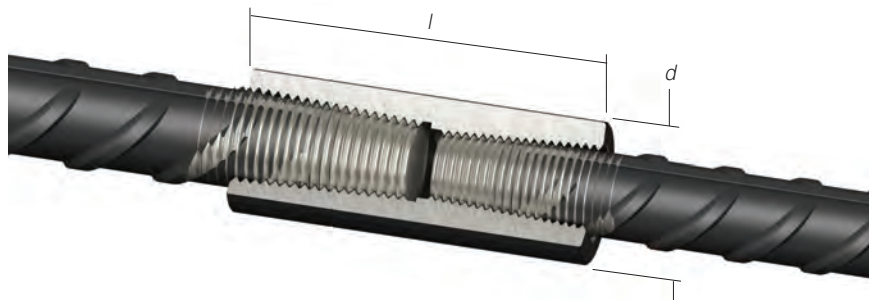

Bar Diameter (mm)	12/14	12/16	14/16	16/18	16/20	18/20	20/22	20/25	20/28	22/26	25/28	25/32	26/30	28/32	30/34	32/40	34/40	40/50	
External Dia. (mm)	d	22	25	25	28	30	30	32	36	42	40	42	48	45	48	55	55	60	70
Coupler Length (mm)	l	65	72	71	75	78	77	82	90	91	92	99	112	104	110	117	138	133	170
Weight (kg)		0.14	0.21	0.19	0.25	0.30	0.28	0.32	0.48	0.65	0.62	0.72	1.11	0.87	1.02	1.59	1.62	1.97	3.31
Torque (Nm)		60/85	60/110	85/110	110/135	110/165	135/165	165/205	165/265	165/275	205/270	265/275	265/285	270/280	275/285	280/295	285/330	295/330	330/350
Part No.		TTT12/14	TTT12/16	TTT14/16	TTT16/18	TTT16/20	TTT18/20	TTT20/22	TTT20/25	TTT20/28	TTT22/26	TTT25/28	TTT25/32	TTT26/30	TTT28/32	TTT30/34	TTT32/40	TTT34/40	TTT40/50

## Tapered Thread Weldable Couplers

Ancon Tapered Thread Weldable couplers provide a convenient means of connecting reinforcing bars to structural steel plates or sections.

Shorter than the standard coupler, it has a tapered thread at one end. The other end is welded directly to the steel. The couplers are manufactured from either steel grade 1045 to ASTM A576 or steel grade C45R to EN10083.

The Tapered Thread Weldable coupler is suitable for welding to structural steels, Grade S275 or Grade S355. The load conditions at the connection must be determined by the designer along with the type and size of weld required. Another important consideration is the type of electrode to be used, which must be matched to the properties of the plate and tube, and to the site conditions under which the welding will be undertaken. Welders should be qualified for the type of weld required. As a minimum standard, welding of the couplers shall be in accordance with the guidance provided in the following documents:

BS EN 287-1	Qualification test of welders, Fusion welding, Steels
BS EN 9606-1:2013	Qualification testing of welders, Fusion welding, Steels
BS EN ISO 15607:2003	Specification and qualification of welding procedures for metallic materials. General rules
BS EN ISO 15609-1:2004	Specification and qualification of welding procedures for metallic materials. Welding procedure specification. Arc welding
BS EN ISO 15614-1:2004 + A2:2012	Specification and qualification of welding procedures for metallic materials. Welding procedure test. Arc and gas welding of steels and arc welding of nickel and nickel alloys
BS EN 1011-1:2009 Welding.	Recommendations for welding of metallic materials. General guidance for arc welding
BS EN 1011-2:2001 Welding.	Recommendations for welding of metallic materials. Arc welding of ferritic steels

**Carbon Equivalent Value** - The Carbon Equivalent value of these couplers may typically vary between 0.50 – 0.75, where the carbon equivalent value is given by  $CEV = C + (Mn)/6 + (Ni+Cu)/15 + (Cr+Mo+V)/5$

For further assistance and technical information please contact us.

### Testing & Approvals

The Welded range of Tapered Thread couplers has been independently tested to demonstrate compliance with the following codes:

DIBt Approval No. Z-1.5-179 - Sections 12.6 and 12.8 of DIN 1045-1:2008-08 and Sections 8.4 and 8.7 of DIN EN 1992-1-1/NA.

ÜA Approval No. R-2.1.9-17-15658

ITB Approval No. AT-15-9037/2013

**Note:** Not all coupler types, sizes and torque values are relevant to the national approvals shown. For details of coupler types and sizes relevant to each national approval please refer to the relevant approval document, which is available on request.

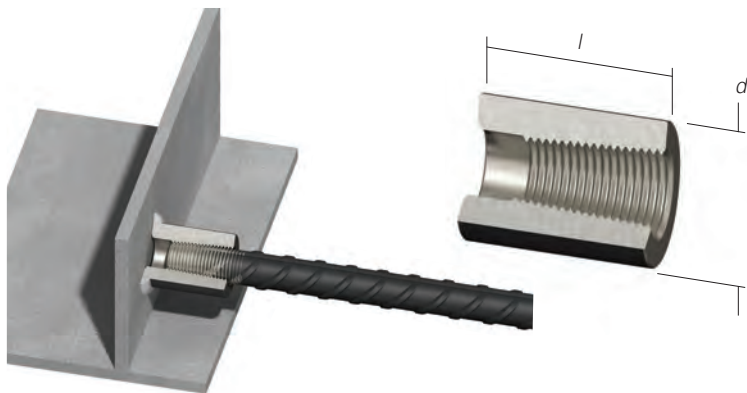

### Weldable Coupler Dimensions

Bar Diameter (mm)	12	14	16	18	20	22	25	26	28	30	32	34	40	50
External Dia. (mm) <i>d</i>	25	30	30	32	36	40	48	50	50	55	55	60	70	85
Coupler Length (mm) <i>l</i>	35	38	42	44	47	52	57	60	63	69	72	78	89	110
Weight (kg)	0.11	0.17	0.18	0.20	0.28	0.38	0.63	0.72	0.72	0.97	0.97	1.28	1.97	3.51
Torque (Nm)	60	85	110	135	165	205	265	270	275	280	285	295	330	350
Part No.	TTW12	TTW14	TTW16	TTW18	TTW20	TTW22	TTW25	TTW26	TTW28	TTW30	TTW32	TTW34	TTW40	TTW50

## Installation

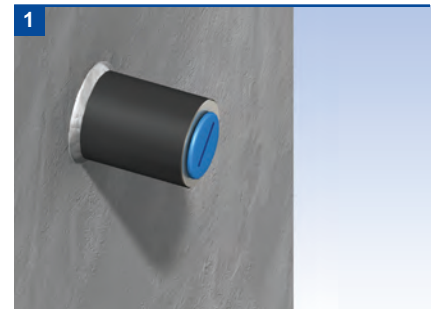

The coupler must first be welded to the steelwork.

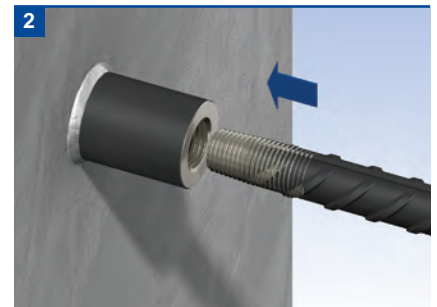

When ready to extend, remove the plastic end cap and position the continuation bar into the sleeve.

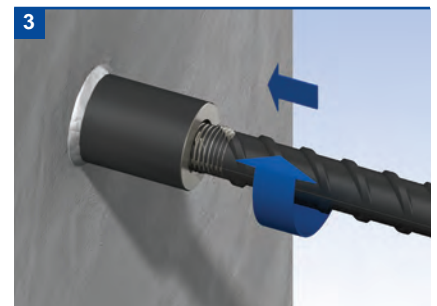

Rotate the bar into the coupler until tight.

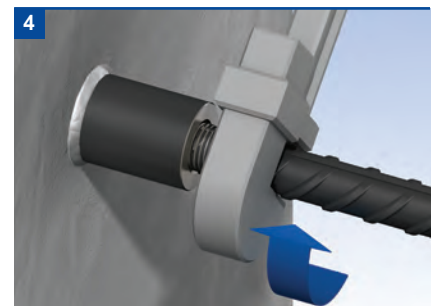

To ensure correct installation, tighten the joint to the specified torque using a calibrated torque wrench on the continuation bar. Tightening torques are shown in the table below.

DIBt



# Reinforcing Bar Couplers

## Tapered Thread Headed Anchors

The Tapered Thread Headed Anchor provides an alternative method of achieving rebar end anchorage within concrete.

Anchorage of rebars within a concrete section is traditionally achieved by means of creating a long hooked end on the rebar. This can lead to problems when positioning the bar and can increase congestion. It can ultimately result in larger than necessary concrete sections at the location of the hooked ends.

Consisting of an oversized coupler, the Tapered Thread Headed Anchor carries the full tension load of the bar when it is bearing against the concrete. The Headed Anchor removes the need for hooked rebar and subsequently reduces congestion and simplifies bar placement. This in turn increases speed of construction and gives greater flexibility in design. Typical applications include pile caps and beam to column connections.

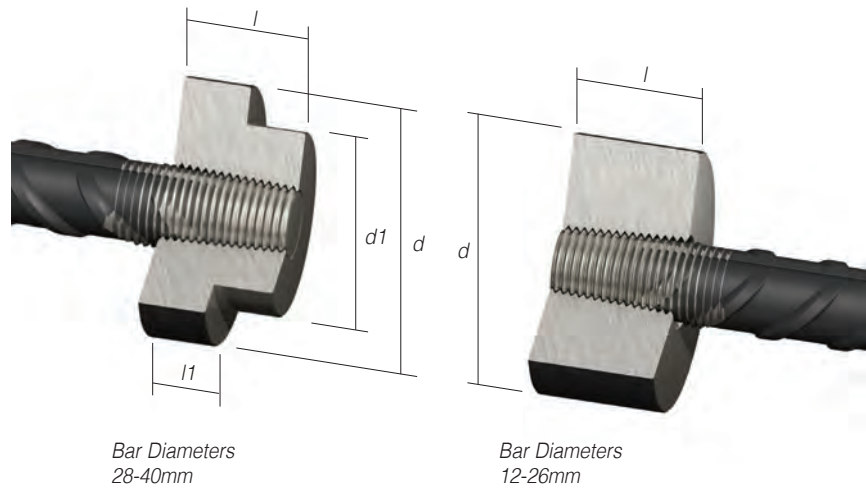

### Tapered Thread Headed Anchor Dimensions

Bar Diameter (mm)		12	14	16	18	20	22	24	25	26	28	30	32	34	36	40
External Dia. (mm)	$d$	40	45	50	55	65	70	80	80	85	90	100	110	115	120	135
External Dia. (mm)	$d1$	-	-	-	-	-	-	-	-	-	78	78	78	78	78	78
Coupler Length (mm)	$l$	27.0	30.0	33.0	35.0	35.0	38.5	42.5	43.5	45.0	46.5	50.0	53.5	56.0	60.5	67.5
Coupler Length (mm)	$l1$	-	-	-	-	-	-	-	-	-	21.5	25.0	28.5	30.0	35.5	42.5
Weight (kg)		0.25	0.34	0.46	0.61	0.83	1.06	1.54	1.57	1.84	1.86	2.23	2.81	3.11	3.62	5.17
Torque (Nm)		60	85	110	135	165	205	250	265	270	275	280	285	295	305	330
Part No.		TTH12	TTH14	TTH16	TTH18	TTH20	TTH22	TTH24	TTH25	TTH26	TTH28	TTH30	TTH32	TTH34	TTH36	TTH40

**Note:** Where tapered thread headed anchors are used, the compressive strength of the concrete shall not be less than strength grade C32/40 (cylinder/cube).

### Testing & Approvals

The Headed Anchor range of Tapered Thread couplers has been independently tested to demonstrate compliance with the following codes:

DIBt Approval No. Z-1.5-179 - Sections 12.6 and 12.8 of DIN 1045-1:2008-08 and Sections 8.4 and 8.7 of DIN EN 1992-1-1/NA.

ÜA Approval No. R-2.1.9-17-15658

ITB Approval No. AT-15-9037/2013

KOMO KIWA certificate No. K75951/04

**Note:** Not all coupler types, sizes and torque values are relevant to the national approvals shown. For details of coupler types and sizes relevant to each national approval please refer to the relevant approval document, which is available on request.



## Tapered Thread Parallel Thread Adaptors

The TTA Tapered Thread Parallel Thread Adaptor accepts a standard metric bolt or studing

It is particularly useful for connecting temporary fixtures to concrete. Once the fixture is removed, reinforcement continuity can be achieved in the second phase construction by using another TTA adaptor and central threaded stud. The TTA is designed to achieve failure loads in excess of 115% of the characteristic strength of grade 500 rebar and meets the requirements of BS EN 1992-1-1:2004 (Eurocode 2) and BS 8110 for mechanical splices.

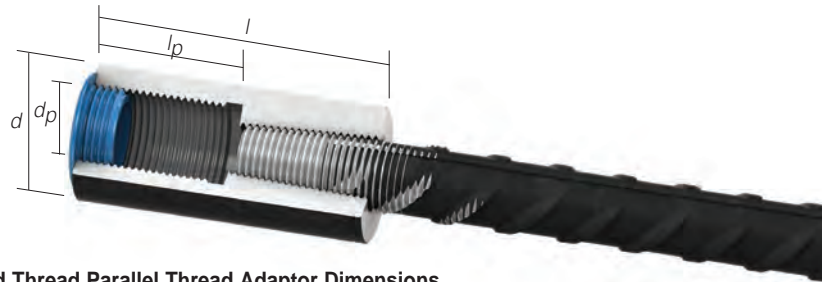

### Tapered Thread Parallel Thread Adaptor Dimensions

Bar Diameter (mm)		12	16	20	25	32
External Dia. (mm)	$d$	25	28	26	42	55
Coupler Length (mm)	$l$	56	68	78	95	115
Parallel Thread Length (mm)	$lp$	24	30	36	45	54
Parallel Thread Size	$dp$	M16x2.0	M20x2.5	M24x3.0	M30x3.5	M36x4.0
Weight (kg)		0.14	0.21	0.40	0.61	1.37
Torque (Nm)		60	110	165	265	285
Part No.		TTA12	TTA16	TTA20	TTA25	TTA32

### Torque Wrenches

#### Torque Wrenches for Couplers and Locknuts

Part No.	E879008	E879009	E879010
Torque (Nm)	60 - 285	85 - 350	20 - 90

### Torque Values (Nm)

Bar Diameter (mm)	12	14	16	18	20	22	24	25	26	28	30	32	34	36	40	50
Standard Coupler	60	85	110	135	165	205	250	265	270	275	280	285	295	305	330	350
Positional Coupler	60	85	110	135	165	205	250	265	270	275	280	285	295	305	330	350
Positional Locknut	20	25	30	40	50	60	65	70	80	80	85	90	100	105	110	130

Bar Diameter (mm)	12/14	12/16	14/16	16/18	16/20	18/20	20/22	20/25	20/28	22/26	25/28	25/32	26/30	28/32	30/34	32/40	34/40	40/50
Transition Coupler	60/85	60/110	85/110	110/135	110/165	135/165	165/205	165/265	165/275	205/270	265/275	265/285	270/280	275/285	280/295	285/330	295/330	330/350

## Accessories

### Threading Machine

Our threading machines provide a fast, simple and reliable threading operation. The machine is compact, making it completely portable and easy to locate. It is of a robust design to provide a long, low maintenance life.

Threading machines are generally located in stockists' yards. For larger projects our machines can be made available for hire. Please contact us for further information.

Training on the correct usage of the threading machine is provided by our technicians.

### Machine Consumables

The following consumables are available:

#### Chaser Sets

Chaser sets are available on a regrindable or disposable basis. Each set can be reground up to 3 times in order to extend cutting life. Please contact us for details.

#### Coolant

We recommend the use of Pencool 5900 Cutting Fluid or a similar water based coolant.

### Thread Protectors

Plastic sleeves are available to protect the tapered threads on reinforcing bars.

### Torque Wrenches

In order to ensure the correct assembly of tapered thread couplers the use of a calibrated torque wrench is essential. Details of wrenches are included in the table opposite. Each Ancon wrench is supplied with a certificate of calibration.



## Other Products

### Reinforcement Continuity Systems

Reinforcement Continuity Systems are an increasingly popular means of maintaining continuity of reinforcement at construction joints in concrete. The Ancon Eazistrip re-bend system is approved by UK CARES and consists of pre-bent bars housed within a galvanised steel casing. Once installed, the bars are straightened ready for lapping with slab reinforcement. Ancon KSN Anchors and Ancon Starter Bars are cast into a concrete wall and accept threaded continuation bars. They easily accommodate long EC2 lap lengths and eliminate the need for on-site bar straightening. KSN Anchors minimise rebar congestion in the wall.



### Shear Load Connectors

Ancon DSD and ESD Shear Load Connectors are used to transfer shear across expansion and contraction joints in concrete. They are more effective at transferring load and allowing movement to take place than standard dowels. The range features rectangular box section sleeves to allow lateral movement in addition to longitudinal movement. A range of Lockable Dowels is available for temporary movement joints in post-tensioned concrete.



### Channel and Bolt Fixings

We offer a wide range of Ancon channels and bolts in order to fix stainless steel masonry support, restraints and windposts to structural frames. Cast-in channels and expansion bolts are used for fixing to the edges of concrete floors and beams.



### Punching Shear Reinforcement

Ancon Shearfix is used within a slab to provide additional reinforcement from punching shear around columns. The system is approved by UK CARES and consists of double-headed steel studs welded to flat rails. Shearfix is designed to suit the load conditions and slab depth at each column using our free calculation software.



### Insulated Balcony Connections

Leviat's thermally insulated connectors minimise heat loss at balcony locations while maintaining structural integrity. They provide a thermal break and, as a critical structural component, transfer moment, shear, tension and compression forces. Standard solutions are available for concrete-to-concrete, steel-to-concrete and steel-to-steel interfaces.

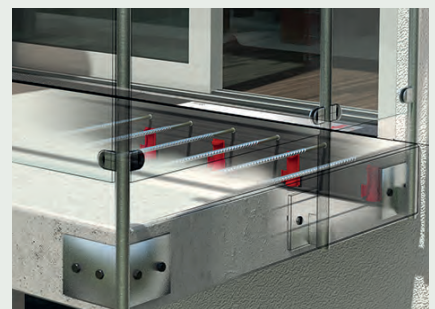



# Leviat®

Innovative engineered products and construction solutions that allow the industry to build safer, stronger and faster.



## Worldwide contacts for Leviat:

### Australia

**Leviat**  
98 Kurrajong Avenue,  
Mount Druitt Sydney, NSW 2770  
Tel: +61 - 2 8808 3100  
Email: info.au@leviat.com

### Austria

**Leviat**  
Leonard-Bernstein-Str. 10  
Saturn Tower, 1220 Wien  
Tel: +43 - 1 - 259 6770  
Email: info.at@leviat.com

### Belgium

**Leviat**  
Industrielaan 2  
1740 Ternat  
Tel: +32 - 2 - 582 29 45  
Email: info.be@leviat.com

### China

**Leviat**  
Room 601 Tower D, Vantone Centre  
No. A6 Chao Yang Men Wai Street  
Chaoyang District  
Beijing · P.R. China 100020  
Tel: +86 - 10 5907 3200  
Email: info.cn@leviat.com

### Czech Republic

**Leviat**  
Business Center Šafránková  
Šafránková 1238/1  
155 00 Praha 5  
Tel: +420 - 311 - 690 060  
Email: info.cz@leviat.com

### Finland

**Leviat**  
Vädursgatan 5  
412 50 Göteborg / Sweden  
Tel: +358 (0)10 6338781  
Email: info.fi@leviat.com

### France

**Leviat**  
6, Rue de Cabanis  
FR 31240 L'Union  
Toulouse  
Tel: +33 - 5 - 34 25 54 82  
Email: info.fr@leviat.com

### Germany

**Leviat**  
Liebigstrasse 14  
40764 Langenfeld  
Tel: +49 - 2173 - 970 - 0  
Email: info.de@leviat.com

### India

**Leviat**  
309, 3rd Floor, Orion Business Park  
Ghodbunder Road, Kapurbawdi,  
Thane West, Thane,  
Maharashtra 400607  
Tel: +91 - 22 2589 2032  
Email: info.in@leviat.com

### Italy

**Leviat**  
Via F.lli Bronzetti 28  
24124 Bergamo  
Tel: +39 - 035 - 0760711  
Email: info.it@leviat.com

### Malaysia

**Leviat**  
28 Jalan Anggerik Mokara 31/59  
Kota Kemuning, 40460 Shah Alam  
Selangor  
Tel: +603 - 5122 4182  
Email: info.my@leviat.com

### Netherlands

**Leviat**  
Oostermaat 3  
7623 CS Borne  
Tel: +31 - 74 - 267 14 49  
Email: info.nl@leviat.com

### New Zealand

**Leviat**  
2/19 Nuttall Drive, Hillsborough,  
Christchurch 8022  
Tel: +64 - 3 376 5205  
Email: info.nz@leviat.com

### Norway

**Leviat**  
Vestre Svanholmen 5  
4313 Sandnes  
Tel: +47 - 51 82 34 00  
Email: info.no@leviat.com

### Philippines

**Leviat**  
2933 Regus, Joy Nostalg,  
ADB Avenue  
Ortigas Center  
Pasig City  
Tel: +63 - 2 7957 6381  
Email: info.ph@leviat.com

### Poland

**Leviat**  
Ul. Obornicka 287  
60-691 Poznań  
Tel: +48 - 61 - 622 14 14  
Email: info.pl@leviat.com

### Singapore

**Leviat**  
14 Benoi Crescent  
Singapore 629977  
Tel: +65 - 6266 6802  
Email: info.sg@leviat.com

### Spain

**Leviat**  
Polígono Industrial Santa Ana  
c/ Ignacio Zuloaga, 20  
28522 Rivas-Vaciamadrid  
Tel: +34 - 91 632 18 40  
Email: info.es@leviat.com

### Sweden

**Leviat**  
Vädursgatan 5  
412 50 Göteborg  
Tel: +46 - 31 - 98 58 00  
Email: info.se@leviat.com

### Switzerland

**Leviat**  
Grenzstrasse 24  
3250 Lyss  
Tel: +41 - 31 750 3030  
Email: info.ch@leviat.com

### United Arab Emirates

**Leviat**  
RA08 TB02, PO Box 17225  
JAFZA, Jebel Ali, Dubai  
Tel: +971 (0)4 883 4346  
Email: info.ae@leviat.com

### United Kingdom

**Leviat**  
President Way, President Park,  
Sheffield, S4 7UR  
Tel: +44 - 114 275 5224  
Email: info.uk@leviat.com

### United States of America

**Leviat**  
6467 S Falkenburg Rd.  
Riverview, FL 33578  
Tel: (800) 423-9140  
Email: info.us@leviat.us

### For countries not listed

Email: info@leviat.com

**Leviat.com**

#### Notes regarding this catalogue

© Protected by copyright. The construction applications and details provided in this publication are indicative only. In every case, project working details should be entrusted to appropriately qualified and experienced persons. Whilst every care has been exercised in the preparation of this publication to ensure that any advice, recommendations or information is accurate, no liability or responsibility of any kind is accepted by Leviat for inaccuracies or printing errors. Technical and design changes are reserved. With a policy of continuous product development, Leviat reserves the right to modify product design and specification at any time.

# Leviat®

For more information on these products, contact:

**Leviat**

President Way  
President Park  
Sheffield, S4 7UR  
United Kingdom

Tel: +44 (0) 114 275 5224

Fax: +44 (0) 114 276 8543

Email: [info.ancon.uk@leviat.com](mailto:info.ancon.uk@leviat.com)

For sales and technical enquiries:

Email: [reinforcement.uk@leviat.com](mailto:reinforcement.uk@leviat.com)

[Ancon.co.uk](http://Ancon.co.uk)

[Leviat.com](http://Leviat.com)

**Imagine. Model. Make.**

**[Leviat.com](http://Leviat.com)**