

Leviat®

International Version

C/S/R	(29)	Et6	
May 2026			



Ancon®

CXL Parallel Thread Couplers

for the Construction Industry

Leviat

We imagine, model and make engineered products and innovative construction solutions that help turn architectural visions into reality and enable our construction partners to build better, safer, stronger and faster.

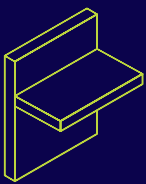

Structural Connections

Systems to form robust, efficient connections, and continuity of concrete reinforcement as necessary, between walls, slabs, columns, beams and balconies, providing structural integrity as well as enhanced thermal and acoustic performance.

- Insulated balcony connectors
- Reinforcing bar couplers
- Concrete Connections
- Reinforcement continuity systems
- Punching shear reinforcement
- Shear load connectors
- Floor Joint Systems
- Precast / Reinforced Columns
- Infrastructure Products
- Precast Connections
- Acoustic dowels and bearings
- Prestress

Other areas of expertise:

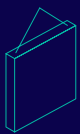

Lifting & Bracing

Systems for the safe and efficient transportation, lifting and temporary bracing of cast concrete elements and tilt-up panels before permanent structural connections are made.

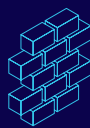

Façade Support & Restraint

Systems for the safe and thermally-efficient fixing of the external building envelope, including brick and natural stone, insulated sandwich panels, curtain walling and suspended concrete façades, and also the repair and strengthening of existing masonry installations.

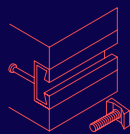

Anchoring & Fixing

Systems for fixing secondary fixtures to concrete, including anchor channels, bolts and inserts; also tension rod systems for roofs and canopies.

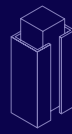

Formwork & Site Accessories

Non-structural accessories that complement our engineered solutions and help keep your construction environment operating safely and efficiently, including moulds for casting standard and special concrete elements and construction essentials such as reinforcing bar spacers.

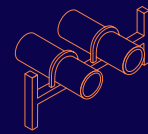

Industrial Technology

Mounting channels, pipe clamps and other versatile framing systems that provide safe fixing in a wide range of industrial applications.

Leviat product ranges:

Ancon | Aschwanden | Connolly | Halfen | Helifix | Isedio | Meadow Burke | Modersohn | Moment | Plaka | Scaldex | Thermomass

Reinforcing Bar Couplers

Lapped joints are not always an appropriate means of connecting reinforcing bars. The use of laps can be time consuming in terms of design and installation and can lead to greater congestion within the concrete because of the increased amount of rebar used.

Ancon couplers can simplify the design and construction of reinforced concrete and reduce the amount of reinforcement required.

Lapped joints are dependent upon the concrete for load transfer. For this reason any degradation in the integrity of the concrete could significantly affect the performance of the joint. The strength of a mechanical splice is independent of the concrete in which it is located and will retain its strength despite loss of cover as a result of impact damage or seismic event.

The range of Ancon reinforcing bar couplers is the most comprehensive available and includes tapered threaded, parallel threaded, mechanically bolted and grouted couplers. Couplers for stainless steel and cryogenic-grade rebars complete the range.

Characteristic Strengths of High Yield Reinforcing Bar

Diameter (mm)	Area (mm ²)	Fy(kN/500N/mm ²)
12	113	56.5
16	201	100.5
20	314	157.0
22	380	190.0
25	491	245.5
28	616	307.8
32	804	402.1
36	1,018	509.0
40	1,256	628.3
50	1,963	981.7



Eurocode 2 compliant



Simplify design and construction



ISO 9001, ISO 14001, ISO 45001



Reduce amount of reinforcement required



Dedicated sales support



Available through major rebar stockists and approved distributors

CXL

CXL couplers produce a full strength joint yet they are among the smallest in the Ancon range, best suited to large scale projects requiring a high volume of couplers.



The end of each bar to be joined is cut square and enlarged by cold forging. This increases the core diameter of the bar to ensure that the joint is stronger than the bar.

Parallel metric threads are cut onto the enlarged ends. The threaded end is then proof tested to a force equal to the characteristic yield strength of the bar. A nominal allowance of +50mm per threaded bar end should be made for cutting square and cold forging.

The threaded ends of the bars are protected by an external plastic sheath. Couplers, which are usually supplied attached to the bar, have their internal threads protected by an internal plastic end cap. For certain applications, especially where CXL is being used in deep pours,

the coupler end caps may not prevent the ingress of concrete fines. For these applications, further protection may be required.

CXL couplers are also available to join bars of different diameters. For further information please contact us.

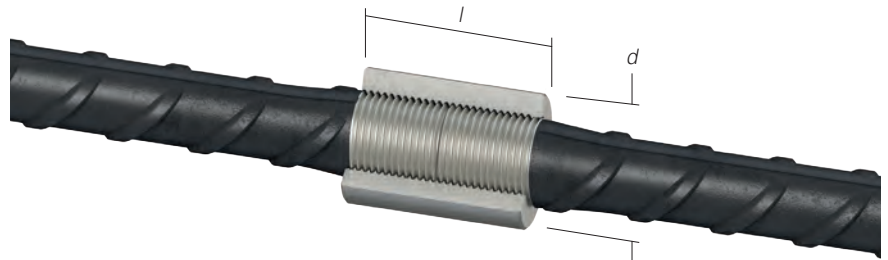

CXL Dimensions

Bar Diameter (mm)	12	16	20	22	25	28	32	36	40	50
External Dia. (mm) d	22	30	35	36	42	48	55	60	65	80
Coupler Length (mm) l	28	40	48	52	60	66	72	84	90	112
Thread Size (mm)	M14	M20	M24	M26	M30	M33	M36	M42	M45	M56
Thread Pitch	2.0	2.5	3.0	3.0	3.5	3.5	4.0	4.5	4.5	5.5
Weight (kg)	0.04	0.09	0.16	0.22	0.32	0.43	0.58	0.87	1.13	2.17
Part No Type A	CXL12/A	CXL16/A	CXL20/A	CXL22/A	CXL25/A	CXL28/A	CXL32/A	CXL36/A	CXL40/A	CXL50/A
Part No Type B	CXL12/B	CXL16/B	CXL20/B	CXL22/B	CXL25/B	CXL28/B	CXL32/B	CXL36/B	CXL40/B	CXL50/B
Part No Type C	-	CXL16/C	CXL20/C	CXL22/C	CXL25/C	CXL28/C	CXL32/C	CXL36/C	CXL40/C	CXL50/C

CXL Type A

The CXL Type A system utilises internally threaded couplers with a single right hand thread and is suitable for applications where the continuation bar can be rotated. The ends of the bars are upset and threaded for half the length of the coupler.

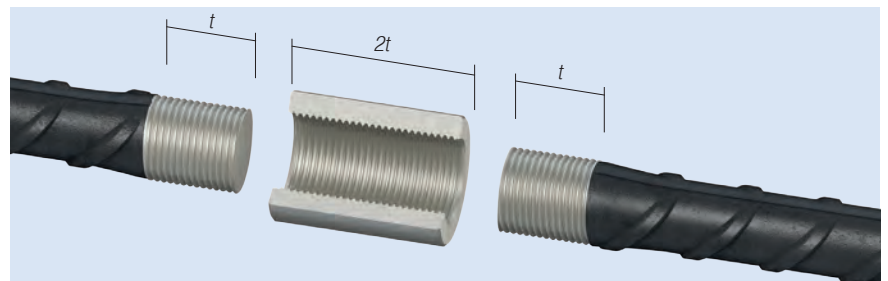

CXL Type B

The CXL Type B uses the same coupler as the Type A system, but one bar is threaded for a full coupler length. It is used for applications where it is difficult but not impossible to rotate the continuation bar.

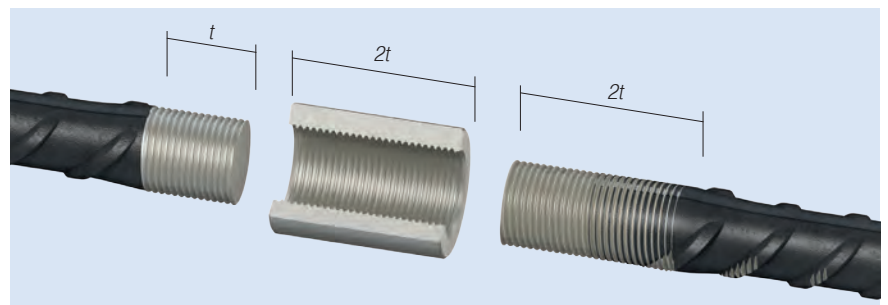

CXL Type C

The CXL Type C system has an additional locknut and is used where the continuation bar cannot be rotated. The continuation bar is threaded for the full coupler length plus the length of the locknut.

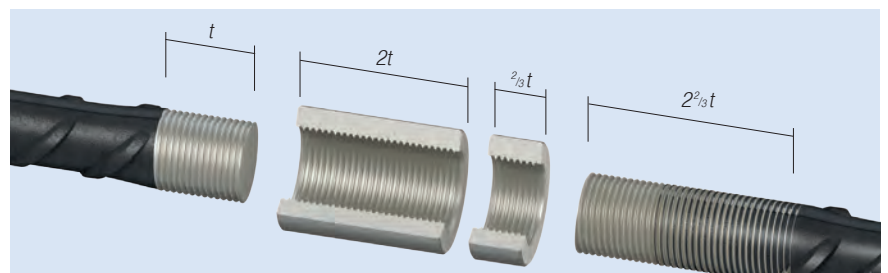

Reinforcing Bar Couplers

Two Stage Construction

In two stage construction utilising Types B and C couplers, it is essential to form a pocket in the face of the first stage concrete. This will create the space for the coupler to run onto the thread of the fixed reinforcing bar.

A pocket former is screwed onto the end of the bar and cast flush with the face of the concrete.

Mobile Bar End Preparation Facility

CXL threading equipment is generally established in the rebar supplier's premises and couplers are usually supplied pre-fixed to the threaded bar ends.

On large contracts where bar end preparation can be carried out on site, equipment can be made available for hire. It should be noted that the hirer will need to provide sufficient power, air, rebar support tressles and crane handling facilities.



Testing & Approvals

CXL couplers are designed and manufactured in accordance with BS EN ISO 9001 and comply with ISO 15835, BS EN 1992-1-1:2004 (Eurocode 2), UNI 11240-1:18 (Scheme SC023) and BS8597, when used with Grade B500 reinforcing bar. Tests have been carried out to show compliance with all independent approvals, ITB Approval No. AT-15-9037/2013, DCL Approval No. TAC 132, IGQ (certificate No. P192), CARES TA1A & B-5066 and ETA 22/0791.

Each of the approvals mentioned here apply to specific bar sizes and bar grades. For details of bar sizes and grades covered, please refer to the relevant certificate, which is available from Leviat on request.



Installation

The CXL Type A System

1

Screw the coupler to the rear of the thread on the fixed bar and lock tight. The bar end should be central within the coupler.

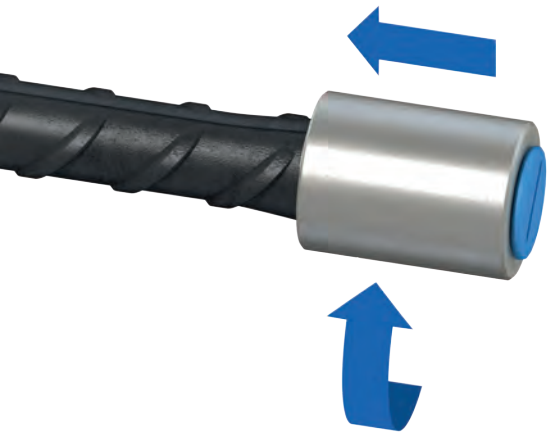

2

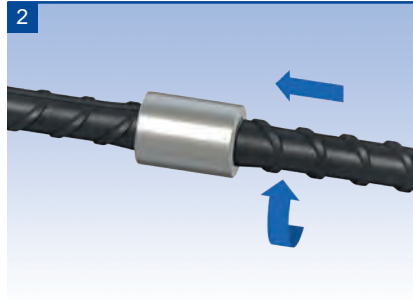

Remove the plastic cap from the coupler. Position and rotate the continuation bar in the coupler.

3

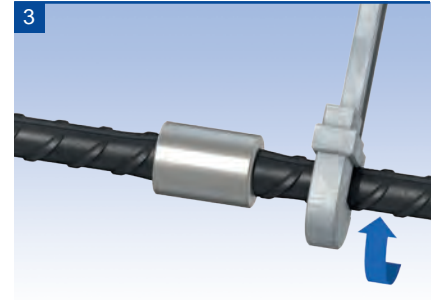

Tighten the joint using a wrench on the continuation bar. After tightening there should be no more than 2-4mm of thread exposed, depending on the diameter of the rebar.

The CXL Type B System

1

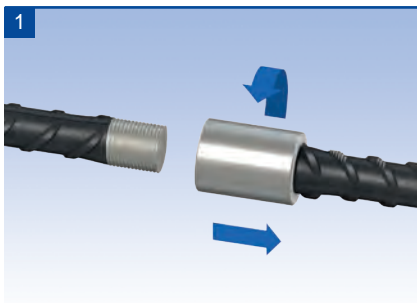

Screw the coupler to the rear of the thread on the continuation bar.

2

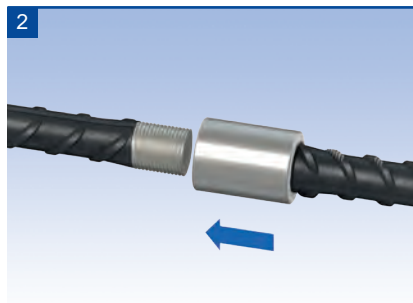

Position the continuation bar with the coupler against the end of the first bar.

3

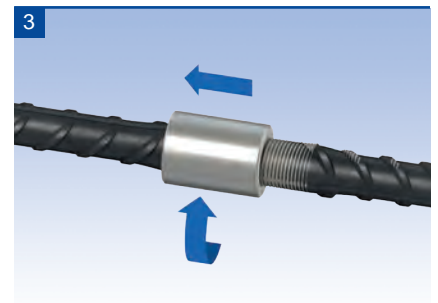

Rotate the coupler from the continuation bar to engage against the rear of the thread on the opposing bar and lock tight.

4

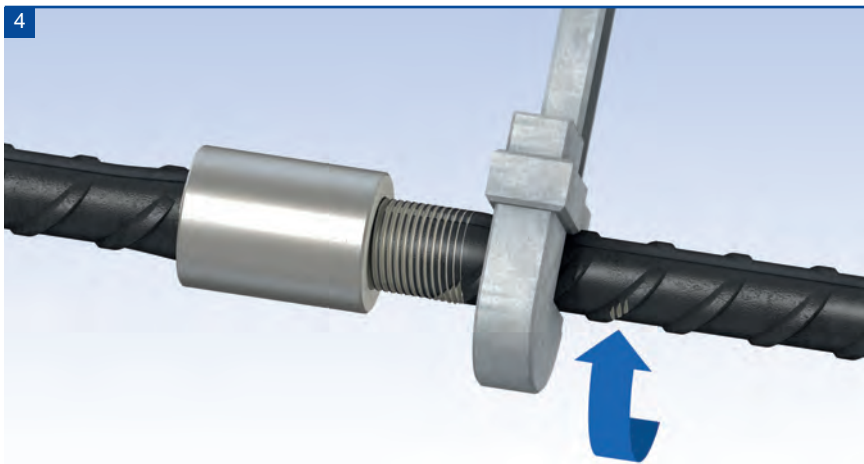

Using a wrench, rotate the continuation bar to lock the two bar ends against each other within the coupler. After tightening, the length of exposed thread should be no more than half of the coupler length plus 2-4mm depending on the diameter of the rebar.



Reinforcing Bar Couplers

The CXL Type C System

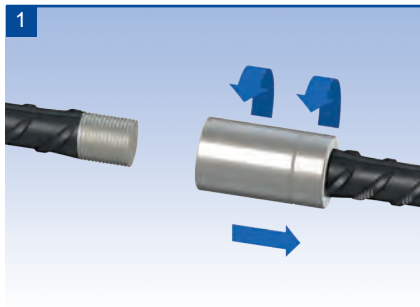

1 Screw the locknut followed by the coupler to the rear of the thread on the continuation bar.

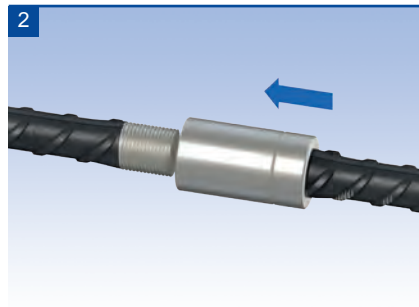

2 Position the continuation bar with the coupler against the end of the first bar.

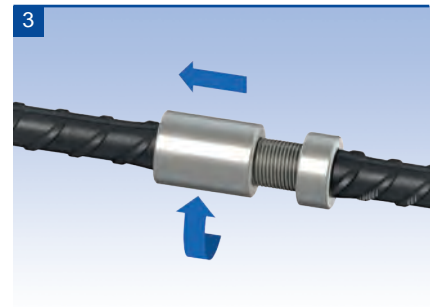

3 Rotate the coupler from the continuation bar to engage against the rear of the thread on the opposing bar and lock tight.

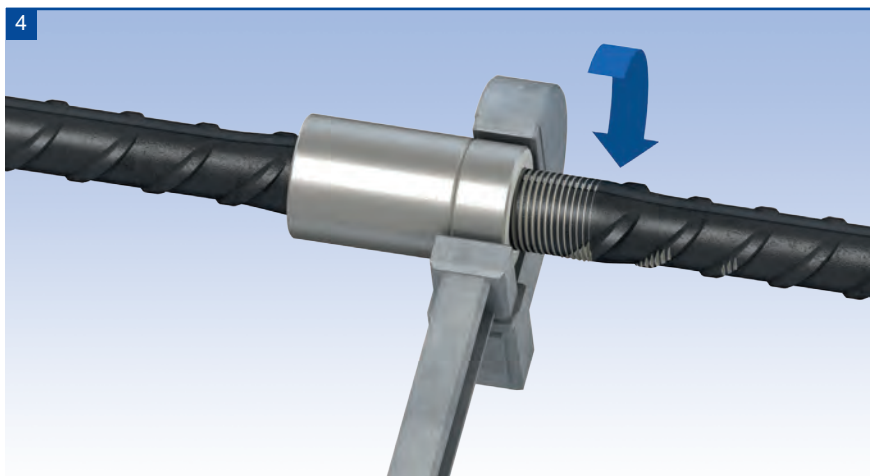

4 Rotate the locknut along the continuation bar to abut the coupler.



5

Hold the rebar in its required orientation and with a wrench tighten the locknut against the coupler.

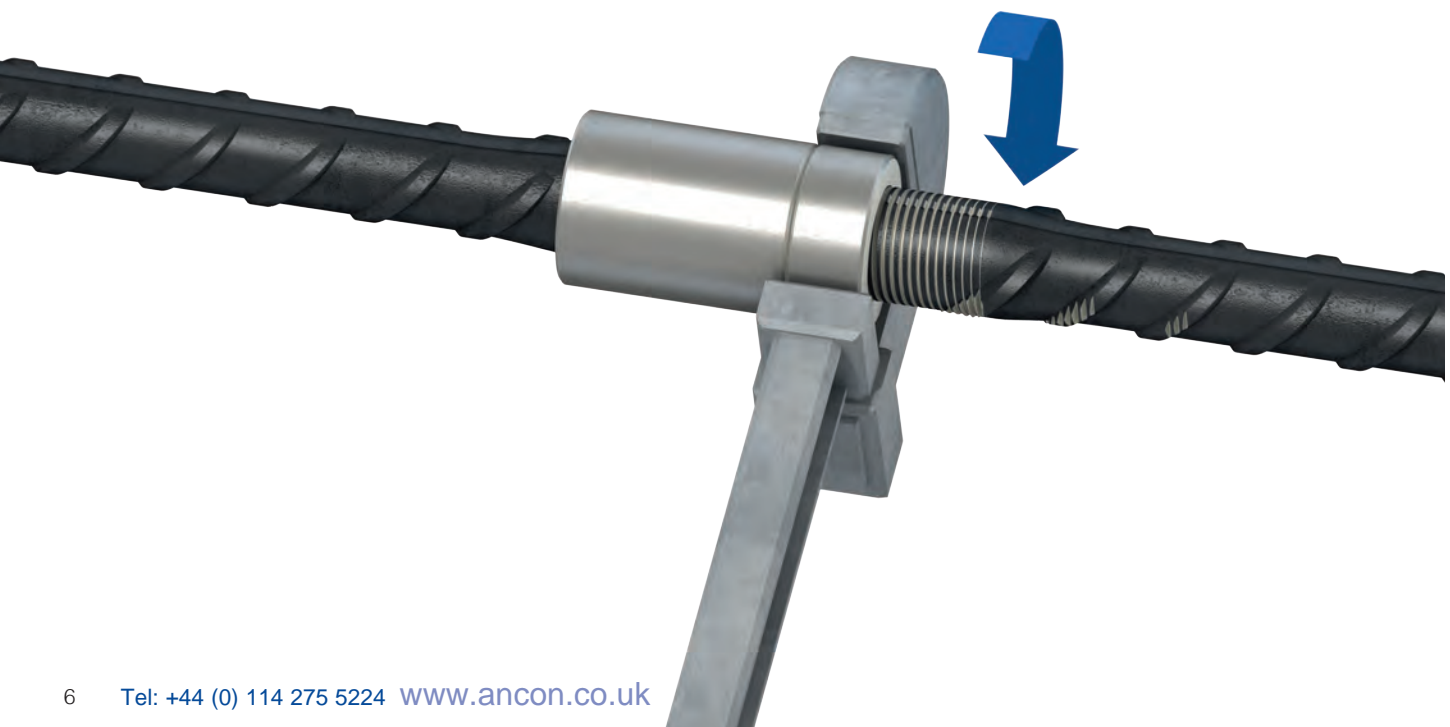

CXL Transition Couplers

Bar Diameter (mm)		12/16	16/20	20/25	25/32	32/40
External Dia. (mm)	d	22	30	35	42	56
Coupler Length (mm)	$2t$	28	40	48	60	72
Thread Size (mm)		M14	M20	M24	M30	M36
Thread Pitch		2.0	2.5	3.0	3.5	4.0
Weight (kg)		0.04	0.09	0.16	0.32	0.58
Part No. A		CXL12/A	CXL16/A	CXL20/A	CXL25/A	CXL32/A
Part No. B		CXL12/B	CXL16/B	CXL20/B	CXL25/B	CXL32/B
Part No. C		CXL12/C	CXL16/C	CXL20/C	CXL25/C	CXL32/C

Other sizes available on request. Contact Leviat for more details. Thread incompatible with standard metric bolts/studs.

* This detail is to be used with micro-alloy / through hardened rebar only, as threading directly onto rebar produced using the quench and temper or thermo-mechanically-treated methods may result in a disproportionate loss of strength.

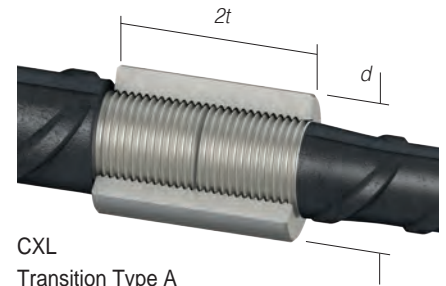

CXL Transition Type A

CXL Transition Locknuts

Bar Diameter (mm)		12/16	16/20	20/25	25/32	32/40
External Dia. (mm)	d	22	30	35	42	55
Locknut Length (mm)	$2t$	12	13	16	20	24
Thread Size (mm)		M14	M20	M24	M30	M36
Thread Pitch		2.0	2.5	3.0	3.5	4.0
Weight (kg)		0.02	0.04	0.05	0.10	0.19
Part No.		CXL12LN	CXL16LN	CXL20LN	CXL25LN	CXL32LN

Other sizes available on request. Contact Leviat for more details. Thread incompatible with standard metric bolts/studs.

CXL Transition Continuation Bars

Please ensure you specify the larger bar for a smaller thread. Eg. a 16mm bar is required for a 12mm thread which would be a CXL 16/12.

Continuation bars available are: CXL 16/12, CXL 20/16, CXL 25/20, CXL 32/25 and CXL 40/32.

CXL Transition Type A

The Type A connection utilises an internally threaded coupler with a single right hand thread and is suitable for applications where the continuation bar can be rotated. The thread on the larger bar is undercut to match the thread size and pitch for the smaller bar. Both bars use standard thread lengths corresponding to half the length of the coupler.

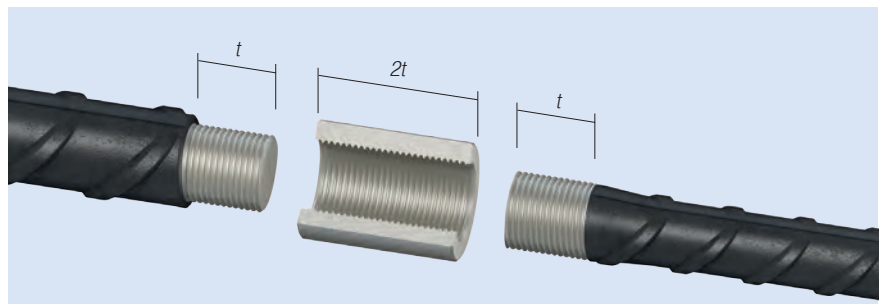

CXL Transition Type B

The Type B connection utilises the same coupler as for Type A, but the smaller bar is threaded for a full coupler length. The larger bar has a standard thread length and is undercut to match the thread size and pitch for the smaller bar. It is usual to rotate the coupler from the smaller diameter bar onto the larger. Type B connections are used where the continuation bar can be rotated for no more than one revolution.

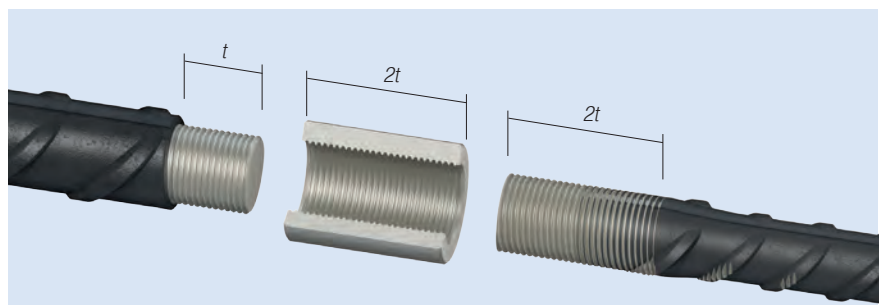

CXL Transition Type C

The Type C connection has an additional locknut. The smaller bar is threaded for the full coupler length plus the length of the locknut. The larger bar has a standard thread length and is undercut to match the thread size and pitch for the smaller bar. It is usual to rotate the coupler from the smaller diameter bar onto the larger. Type C connections are used where the continuation bar is impossible to rotate.

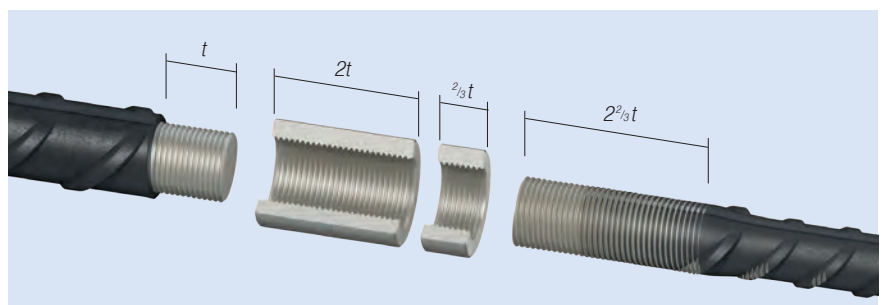

Reinforcing Bar Couplers

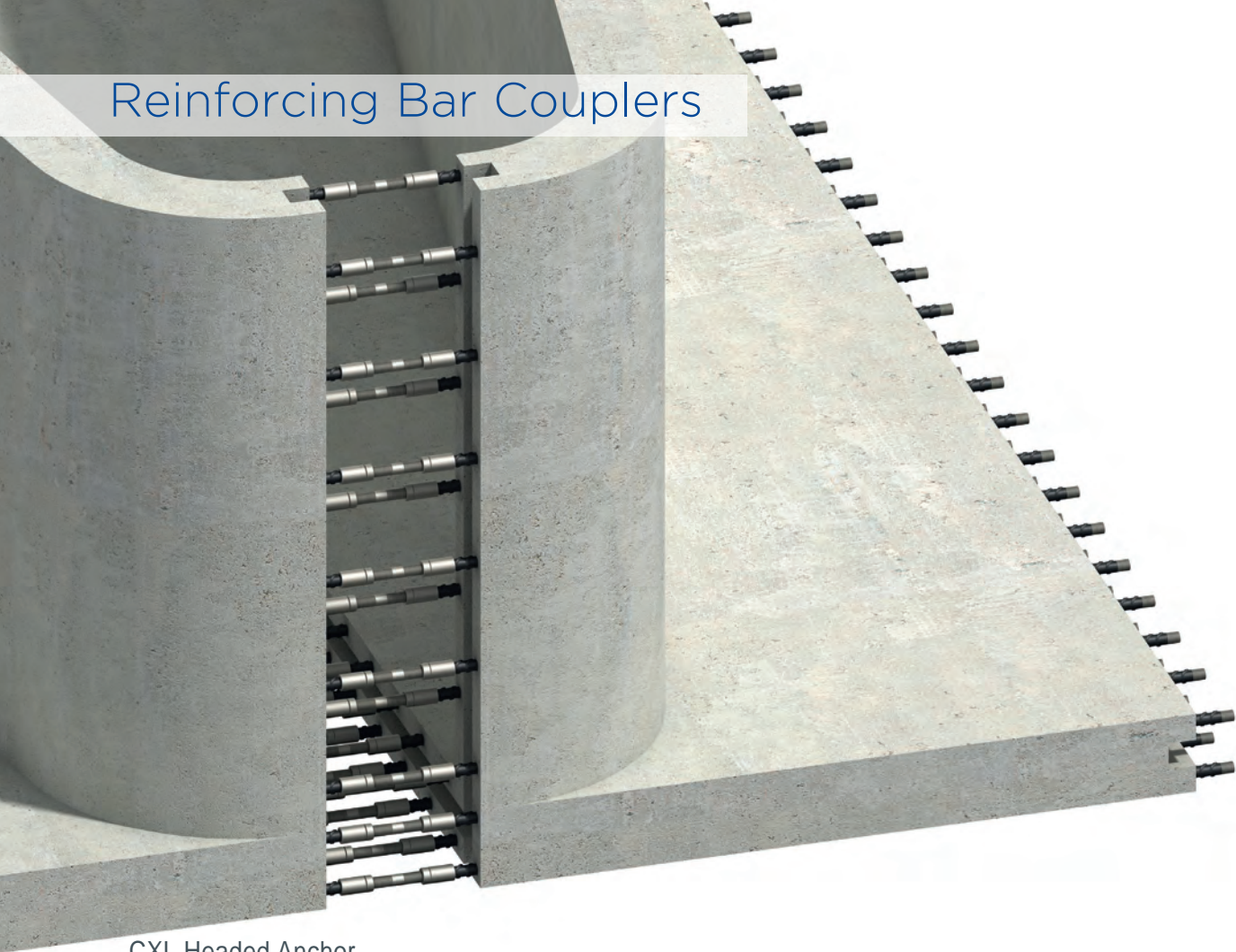

CXL Headed Anchor

The Ancon CXL Headed Anchor provides an effective and proven method of achieving rebar end anchorage within concrete.

Anchorage of reinforcement within a concrete section is traditionally achieved by means of creating a long hooked end to the bar. These hooks can lead to problems when positioning the bar and can increase congestion. This can ultimately result in larger than necessary concrete sections at the location of hooked ends.

The CXL Headed Anchor is essentially an oversized coupler capable of carrying the full tension load of the bar when it bears against the concrete in which it is cast. The Headed Anchor removes the need for the hooked rebar end and can subsequently reduce congestion, simplifying bar placement. This in turn increases the speed of construction and gives greater flexibility in design. Typical applications include pile caps and beam-to-column connections.

To attach the Headed Anchor to the rebar, it is first necessary to enlarge the bar end and then form the thread on the enlarged bar end using a thread cutting machine. As with the CXL coupler connection, the thread is such that the cross-sectional area of the bar end is not reduced, thus ensuring the tensile strength of the connection matches or exceeds that of the parent bar.

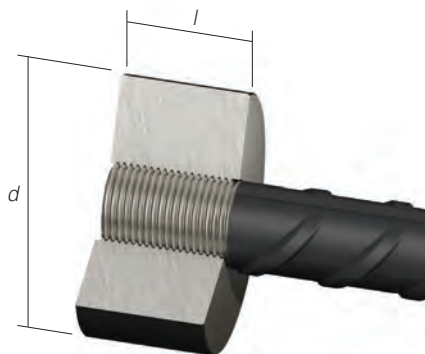

CXL Headed Anchor

Bar Diameter (mm)	16	20	25	32	40
External Diameter (mm) <i>d</i>	52	65	80	110	135
Anchor Thickness (mm) <i>l</i>	20	24	30	36	45
Thread Size	M20	M24	M30	M36	M45
Anchor Weight (kg)	0.27	0.56	1.03	2.43	4.55
Header Anchor Reference	CXL16HA	CXL20HA	CXL25HA	CXL32HA	CXL40HA

Other sizes are available on request. Contact Leviat for more details.

Concrete Strength

When the above sizes of CXL Headed Anchors are used, the compressive strength of the concrete shall not be less than strength grade C32/40 (cylinder/cube). Where a lower concrete stress is required, Headed Anchors can be supplied to a larger diameter to suit the specific application.

CXL Welded Couplers

CXL welded couplers provide a convenient means of connecting reinforcing bars to structural steel plates or sections. One end is internally threaded with the CXL thread form; the other end is prepared for welding to the steel.

The coupler is suitable for welding to structural steels EN BS 10025, Grade S275 (43A) or Grade S355 (Grade 50B), however the load conditions at the connection must be determined by the designer responsible for the structural element, along with the type and size of weld required.

Other important considerations include the type of electrode to be used, which must be matched to the properties of the plate and tube, and to the site conditions under which the welding will be undertaken. Welders should be qualified for the type of weld required.

As a minimum standard, welding of the couplers shall be in accordance with the guidance provided in the following documents:

BS EN ISO 15614-1:2004+A2:2012 Specification and qualification of welding procedures for metallic materials. Welding procedure test. Arc and gas welding of steels and arc welding of nickel and nickel alloys

BS EN 287-1 Qualification testing of welders, fusion welding, steels

BS EN 9606-1:2013 Qualification testing of welders, fusion welding, steels

BS EN ISO 15607:2003 Specification and qualification of welding procedures for metallic materials. General rules BS EN ISO 15609-1:2004 Specification and qualification of welding procedures for metallic materials. Welding procedure specification. Arc welding

BS EN 1011-1:2009 Welding. Recommendations for welding of metallic materials. General guidance for arc welding

BS EN 1011-2:2001 Welding. Recommendations for welding of metallic materials. Arc welding of ferritic steels

CXL Welded Couplers are manufactured from either Steel Grade 1045 to ASTM A576 or Steel Grade C45R to EN10083.

Carbon Equivalent Value - The Carbon Equivalent value of these couplers may typically vary between 0.50 - 0.75, where the carbon equivalent value is given by
 $CEV = C + (Mn)/6 + (Ni+Cu)/15 + (Cr+Mo+V)/5$

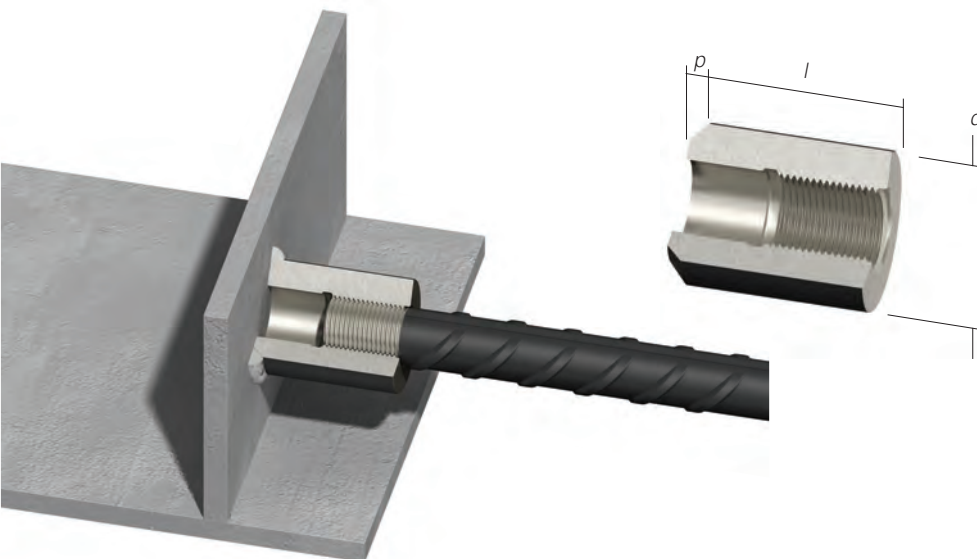

CXL Weldable Couplers

Bar Diameter (mm)		16	20	25	32	40
Coupler Diameter (mm)	<i>d</i>	33	38	48	57	72
Coupler Length (mm)	<i>l</i>	40	48	60	72	90
Thread Size		M20	M24	M30	M36	M45
Weld Preparation (mm)	<i>p</i>	5.5	5.0	5.5	11.0	12.5
Coupler Weight (kg)		0.18	0.30	0.58	0.96	1.91
Coupler Reference		CXL16W	CXL20W	CXL25W	CXL32W	CXL40W

Other sizes are available on request. Contact Leviat for more details.

Installation CXL Weldable Couplers

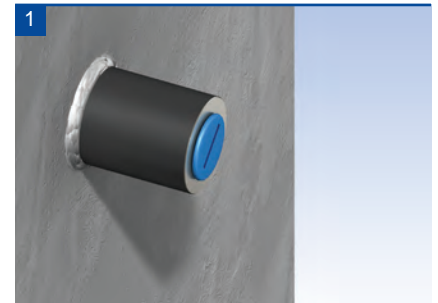

The coupler must first be welded to the steelwork.

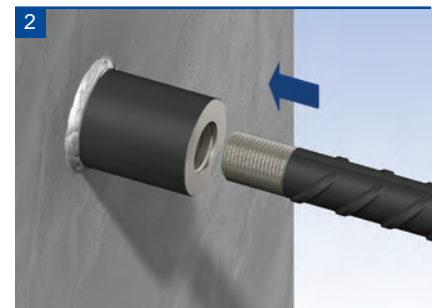

When ready to extend, remove the plastic end cap and position the continuation bar into the sleeve.

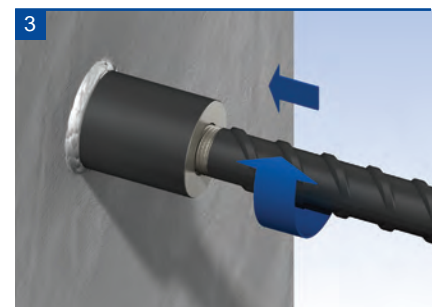

Rotate the bar into the coupler until tight.

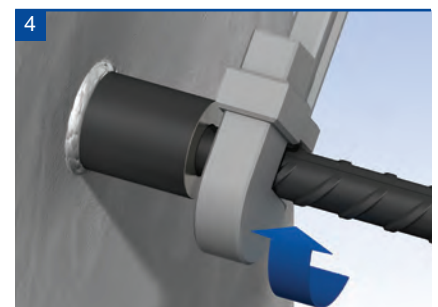

Tighten the continuation bar using a wrench.

Other Products

Reinforcement Continuity Systems

Reinforcement Continuity Systems are an increasingly popular means of maintaining continuity of reinforcement at construction joints in concrete. The Ancon Eazistrip re-bend system is approved by UK CARES and consists of pre-bent bars housed within a galvanised steel casing. Once installed, the bars are straightened ready for lapping with slab reinforcement. Ancon KSN Anchors and Ancon Starter Bars are cast into a concrete wall and accept threaded continuation bars. They easily accommodate long EC2 lap lengths and eliminate the need for on-site bar straightening. KSN Anchors minimise rebar congestion in the wall.



Shear Load Connectors

Ancon DSD and ESD Shear Load Connectors are used to transfer shear across expansion and contraction joints in concrete. They are more effective at transferring load and allowing movement to take place than standard dowels. The range features rectangular box section sleeves to allow lateral movement in addition to longitudinal movement. A range of Lockable Dowels is available for temporary movement joints in post-tensioned concrete.



Channel and Bolt Fixings

Leviat offers a wide range of Ancon channels and bolts in order to fix stainless steel masonry support, restraints and windposts to structural frames. Cast-in channels and expansion bolts are used for fixing to the edges of concrete floors and beams.



Punching Shear Reinforcement

Ancon Shearfix is used within a slab to provide additional reinforcement from punching shear around columns. The system is approved by UK CARES and consists of double-headed steel studs welded to flat rails. Shearfix is designed to suit the load conditions and slab depth at each column using our free calculation software.



Insulated Balcony Connections

Leviat's thermally insulated connectors minimise heat loss at balcony locations while maintaining structural integrity. They provide a thermal break and, as a critical structural component, transfer moment, shear, tension and compression forces. Standard solutions are available for concrete-to-concrete, steel-to-concrete and steel-to-steel interfaces.

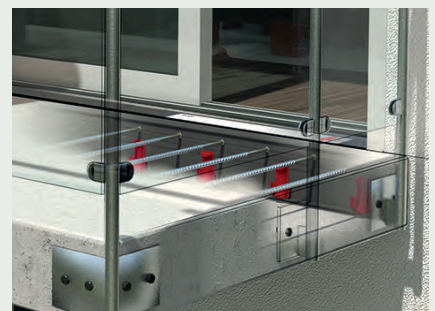

Worldwide contacts for Leviat:

Australia

Leviat
98 Kurrajong Avenue,
Mount Druitt Sydney, NSW 2770
Tel: +61 - 2 8808 3100
Email: info.au@leviat.com

Austria

Leviat
Leonard-Bernstein-Str. 10
Saturn Tower, 1220 Wien
Tel: +43 - 1 - 259 6770
Email: info.at@leviat.com

Belgium

Leviat
Industrielaan 2
1740 Ternat
Tel: +32 - 2 - 582 29 45
Email: info.be@leviat.com

China

Leviat
Room 601 Tower D, Vantone Centre
No. A6 Chao Yang Men Wai Street
Chaoyang District
Beijing · P.R. China 100020
Tel: +86 - 10 5907 3200
Email: info.cn@leviat.com

Czech Republic

Leviat
Business Center Šafránková
Šafránková 1238/1
155 00 Praha 5
Tel: +420 - 311 - 690 060
Email: info.cz@leviat.com

Finland

Leviat
Vädursgatan 5
412 50 Göteborg / Sweden
Tel: +358 (0)10 6338781
Email: info.fi@leviat.com

France

Leviat
6, Rue de Cabanis
FR 31240 L'Union
Toulouse
Tel: +33 - 5 - 34 25 54 82
Email: info.fr@leviat.com

Germany

Leviat
Liebigstrasse 14
40764 Langenfeld
Tel: +49 - 2173 - 970 - 0
Email: info.de@leviat.com

India

Leviat
309, 3rd Floor, Orion Business Park
Ghodbunder Road, Kapurbawdi,
Thane West, Thane,
Maharashtra 400607
Tel: +91 - 22 2589 2032
Email: info.in@leviat.com

Italy

Leviat
Via F.lli Bronzetti 28
24124 Bergamo
Tel: +39 - 035 - 0760711
Email: info.it@leviat.com

Malaysia

Leviat
28 Jalan Anggerik Mokara 31/59
Kota Kemuning, 40460 Shah Alam
Selangor
Tel: +603 - 5122 4182
Email: info.my@leviat.com

Netherlands

Leviat
Oostermaat 3
7623 CS Borne
Tel: +31 - 74 - 267 14 49
Email: info.nl@leviat.com

New Zealand

Leviat
2/19 Nuttall Drive, Hillsborough,
Christchurch 8022
Tel: +64 - 3 376 5205
Email: info.nz@leviat.com

Norway

Leviat
Vestre Svanholmen 5
4313 Sandnes
Tel: +47 - 51 82 34 00
Email: info.no@leviat.com

Philippines

Leviat
2933 Regus, Joy Nostalg,
ADB Avenue
Ortigas Center
Pasig City
Tel: +63 - 2 7957 6381
Email: info.ph@leviat.com

Poland

Leviat
Ul. Obornicka 287
60-691 Poznań
Tel: +48 - 61 - 622 14 14
Email: info.pl@leviat.com

Singapore

Leviat
14 Benoi Crescent
Singapore 629977
Tel: +65 - 6266 6802
Email: info.sg@leviat.com

Spain

Leviat
Polígono Industrial Santa Ana
c/ Ignacio Zuloaga, 20
28522 Rivas-Vaciamadrid
Tel: +34 - 91 632 18 40
Email: info.es@leviat.com

Sweden

Leviat
Vädursgatan 5
412 50 Göteborg
Tel: +46 - 31 - 98 58 00
Email: info.se@leviat.com

Switzerland

Leviat
Grenzstrasse 24
3250 Lyss
Tel: +41 - 31 750 3030
Email: info.ch@leviat.com

United Arab Emirates

Leviat
RA08 TB02, PO Box 17225
JAFZA, Jebel Ali, Dubai
Tel: +971 (0)4 883 4346
Email: info.ae@leviat.com

United Kingdom

Leviat
President Way, President Park,
Sheffield, S4 7UR
Tel: +44 - 114 275 5224
Email: info.uk@leviat.com

United States of America

Leviat
6467 S Falkenburg Rd.
Riverview, FL 33578
Tel: (800) 423-9140
Email: info.us@leviat.us

For countries not listed

Email: info@leviat.com

Leviat.com

Notes regarding this catalogue

© Protected by copyright. The construction applications and details provided in this publication are indicative only. In every case, project working details should be entrusted to appropriately qualified and experienced persons. Whilst every care has been exercised in the preparation of this publication to ensure that any advice, recommendations or information is accurate, no liability or responsibility of any kind is accepted by Leviat for inaccuracies or printing errors. Technical and design changes are reserved. With a policy of continuous product development, Leviat reserves the right to modify product design and specification at any time.

Leviat®

For more information on these products, contact:

Leviat

President Way
President Park
Sheffield, S4 7UR
United Kingdom

Tel: +44 (0) 114 275 5224

Fax: +44 (0) 114 276 8543

Email: info.ancon.uk@leviat.com

For sales and technical enquiries:

Email: reinforcement.uk@leviat.com

Ancon.co.uk

Leviat.com

Imagine. Model. Make.

Leviat.com